

For opening widths to	No. panels	Kit no.
1500mm	2	HF40/15
3000mm	4	HF40/30
Max leaf size	2400 x 750 x 40mm	
Max leaf weight	40kg	

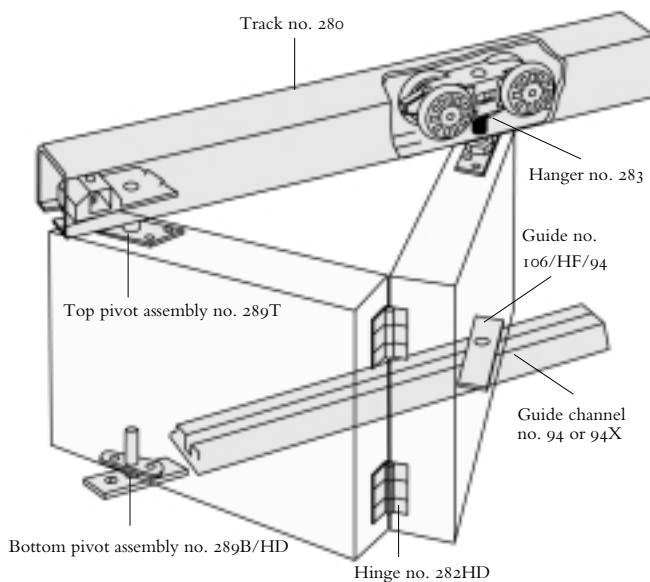

(See Component/Accessory pp 52-56 for product descriptions)

SOFFIT FIXED

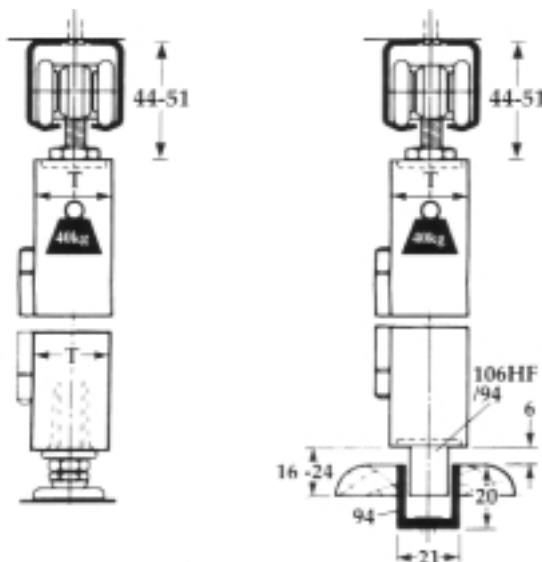

All dimensions in mm

For efficient and easy-to-use medium weight folding doors, neatly stacking at one side. If doors are required to stack at both sides additional pivots are required. Soffit fixing only is available.

KITS

Kits HF40/15 and HF40/30 contain: top and bottom pivots for fixing into end panel; 4 nylon bodied, needle roller bearing hangers with top plate; hinges; roller guides no.106/HF/94; screws; fixing instructions, and steel track no. 280. Guide channel no. 94 or 94X should be separately ordered to the same length as the track.

FITTING PACKS

2 and 4 leaf fitting packs contain all the components contained in the kits except the track. Order also track no. 280 or aluminium section track no. 280A. Guide channel no.94 or 94X should be separately ordered to the same length as the track.

OPTIONAL EXTRAS

Optional extras include: flushbolt no. 333; flushpull no. 400 (see pp 52-57 for full product description). Bulk component packs are also available.

INSTALLATION NOTES

(also see drawing)

For panels with maximum single weight 40kg, maximum dimensions 750mm wide x 2400mm high and thickness 20-40mm; 12 panels (6 each side maximum). Roller guides should be fitted to alternate panels (see drawing) to run in the guide channel.