



SWING DOOR

Automatic door drives

Contents

Overview	04
Types of installation	05

AUTOMATIC SWING DOOR SYSTEMS

For fire and smoke protection doors (F)	8
With integrated closing sequence control (IS)	9
With integrated closing sequence control for double leaf fire and smoke protection doors (F-IS)	10
With integrated closing sequence control for double leaf doors, automatic doors and door closer function (IS/TS)	11
For smoke and heat extraction fresh air solutions as well as doors along escape and rescue routes (Invers)	12
For large and heavy as well as highly frequented doors (EN7)	13
For accessible toilets	14

SWING DOOR DRIVES

Ecturn	18
Ecturn Inside	30
Slimdrive EMD	36
Powerturn	50

ACCESSORIES

Cover, mounting plate, link arm, roller guide rail	70
Operating automatic swing doors	71
Automatic activation	72
Manual activation	73
Protection	74
Service tools	80

REFERENCES	82
------------	----

OVERVIEW

	Ecturn	Slimdrive EMD	Powerturn
PRODUCT FEATURES			
Dimensions drive (H x W x D)	60x580x60 mm	70x650x121 mm	70x720x130 mm
Leaf weight (max.)	125 kg	180 kg 230 kg*	600 kg
Leaf width (min.)	GLS / RS ¹	850 mm	800 mm
	GST	650 mm	
Leaf width (max.)	GLS / RS ¹	1400 mm	1600 mm
	GST	1100 mm	
Hinge clearance for double leaf doors	GLS / RS ¹	1700–2500 mm	1600 – 3200 mm
	GST	1500–2800 mm	
Opening and closing speed adjustable	●	●	●
Electrical closing sequence control		●	●
Exterior doors / interior doors	● / ●	● / ●	● / ●
Can be integrated in the door leaf or door frame	●**		
Single leaf / double leaf	● / –	● / ●	● / ●
Guide rail / roller guide rail / link arm	● / – / ●	– / ● / ●	– / ● / ●
FUNCTIONS			
Automatic	●	●	●
Push & Go adjustable	●	●	●
Low-energy mode	●	●	●
Smart swing			●
Servo		●	●
VARIANTS			
For fire and smoke protection doors (F)		●*	●
With integrated smoke switch (F/R)		●*	●
With integrated closing sequence control (IS)		●*	●
With integrated closing sequence control for double leaf fire and smoke protection doors (F-IS)		●*	●
With IS for double leaf doors, automatic doors and door closer function (IS/TS)			●
For smoke and heat extraction fresh air supply and escape and rescue routes (Invers)		●	
For automation of large, heavy doors (EN7)			●

● = Yes | RS = Roller guide rail | GLS = Guide rail | GST = Link arm | 1 = GLS: Ecturn / RS: Slimdrive and Powerturn | * = Slimdrive EMD-F |

** = Ecturn Inside

→ **Note:** The maximum possible leaf weight in relation to leaf width can be found in the chapter on areas of application (charts).

TYPES OF INSTALLATION FOR SWING DOOR SYSTEMS

The following illustrations show the possible applications for swing doors and the drives which can be used to realise this application.

→ **Notes:** A door stopper is always necessary. We recommend the type of installation opposite hinge side with link arm for exterior doors. Wind loads and underpressure or excess pressure must also be taken into account.

INSTALLATION ON HINGE SIDE

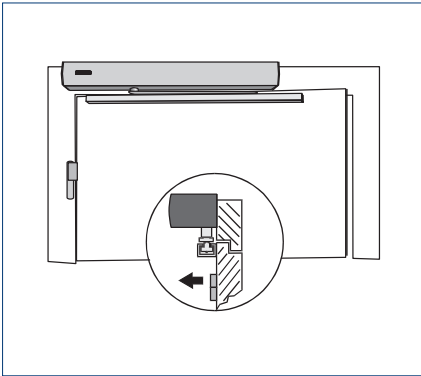

Transom installation with guide rail / roller guide rail
ECturn | Slimdrive EMD | Powerturn

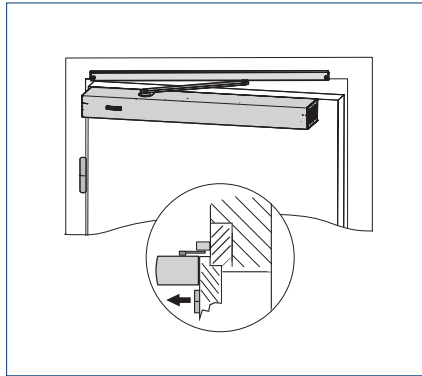

Door leaf installation with guide rail / roller guide rail
ECturn | Slimdrive EMD | Powerturn

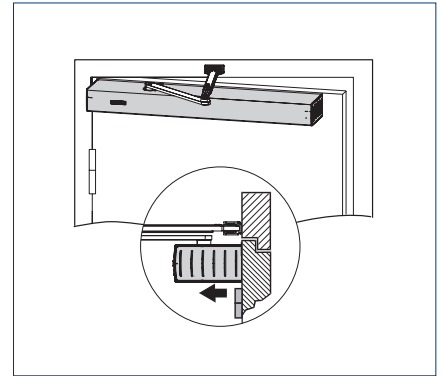

Door leaf installation with link arm
ECturn | Powerturn

INSTALLATION ON THE OPPOSITE HINGE SIDE

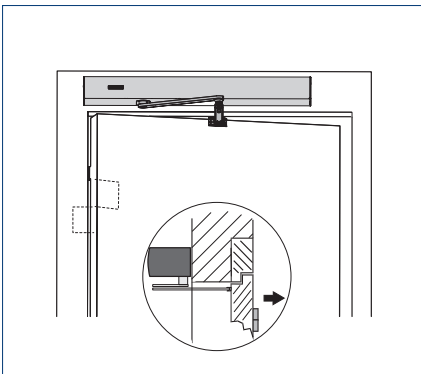

Transom installation with link arm
ECturn | Slimdrive EMD | Powerturn

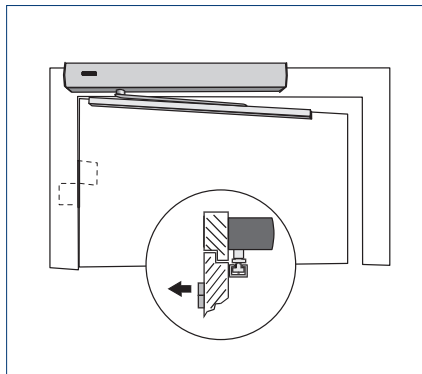

Transom installation with guide rail / roller guide rail
ECturn | Slimdrive EMD | Powerturn

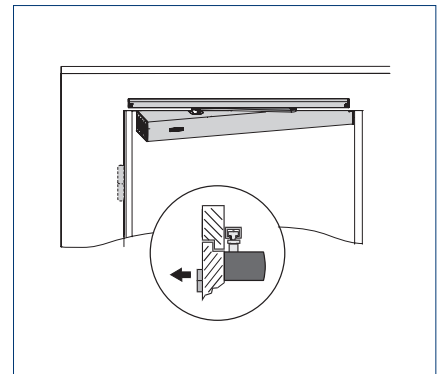

Door leaf installation with guide rail / roller guide rail
ECturn | Powerturn

INSTALLATION IN THE DOOR LEAF / INSTALLATION IN THE DOOR FRAME

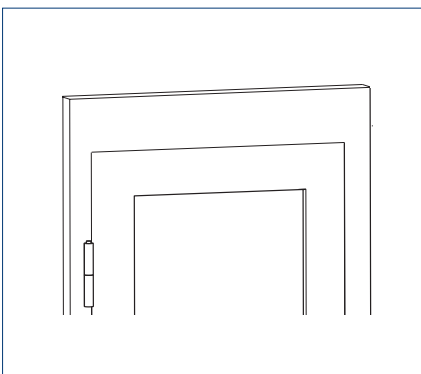

ECturn Inside



SWING DOOR

Automatic swing door systems

They can no longer be ignored in our day-to-day lives: We encounter automatic swing doors at every turn, in shopping centres, office buildings, airports or houses. With swing door systems from GEZE, you'll find a system solution for your building, with which single and double leaf swing doors and even fire protection doors can open and close automatically. In this way, you will not just be optimising your doors in terms of convenience and safety, but will also be saving additional energy.



Variant F



With GC 338 sensor strip (photo: Jürgen Pollak / GEZE GmbH)

Swing door systems for fire and smoke protection doors

AREAS OF APPLICATION

- Use in the Slimdrive EMD-F and Powerturn F product families
- Automatic opening and closing, as well as holding open of fire and smoke protection doors
- For right and left single-action doors

PRODUCT FEATURES

- Secure closing of fire protection doors by triggering the hold-open system and closing via the mechanical energy storage device
- Mechanical and electrical latching action which accelerates the door shortly before the closed position
- Full comfort in normal operation
- The power supply circuit is interrupted by the circuit breaker board, the drive unit retains the door closer function
- Door closer with automatic opening according to DIN 18263 Part 4 are part of the hold-open systems and need official building approval
- Powerturn F/R and Slimdrive EMD-F/R with integrated smoke switch fulfil maximum design requirements

Variant IS



Medicus Clinic in Wrocławiu, Poland (photo: Fotografia Maciej Lulko / GEZE GmbH)

Swing door systems with integrated closing sequence control

AREAS OF APPLICATION

- Use in the Slimdrive EMD-F and Powerturn product families
- Reliable closing of the door through the closing sequence control
- For double leaf doors

PRODUCT FEATURES

- Closing sequence control ensures that the passive leaf closes first on double leaf doors.
- In automatic mode, the electrical closing sequence control is always available
- Mechanical closing sequence control ensures secure closing of a double leaf system, even if there is a power failure

Variant F-IS



Klinikum Düsseldorf, Germany (photo: Lothar Wels / GEZE GmbH)

Swing door systems with integrated closing sequence control for double leaf fire and smoke protection doors

AREAS OF APPLICATION

- Use in the Slimdrive EMD-F and Powerturn F product families
- Automatic opening and closing of double leaf fire protection doors
- For double leaf single-action doors

PRODUCT FEATURES

- Mechanical and electrical latching action which accelerates the door shortly before the closed position
- The drive is switched to passive mode via the circuit breaker board and closes via the integrated mechanical energy storage device
- The integrated mechanical closing sequence control (tested according to EN 1158) ensures a secure closing of the double leaf fire protection door
- Powerturn F/R-IS and Slimdrive EMD-F/R-IS with integrated smoke switch fulfil maximum design requirements

Variant IS/TS



ESO Supernova Planetarium & Visitor Centre, Garching, Germany (photo: Robert Sprang / GEZE GmbH)

Swing door systems with integrated closing sequence control for double leaf doors with automatic active leaf and manual optional leaf

AREAS OF APPLICATION

- Use in the Powerturn product family on standard and fire and smoke protection doors
- Preferred in installation situations where mainly the active leaf is opened
- Particularly suitable for asymmetrical door systems
- Opening and closing, as well as holding open of fire and smoke protection doors as Powerturn F-IS/TS variant
- For right and left single-action doors

PRODUCT FEATURES

- Active leaf automation with swing door drive, passive leaf fitted with door closer
- Individual adjustment of the opening and closing speed
- Activation with the usual pulse generators
- Uniform drive design to meet the highest demands in terms of appearance
- Invisible smoke control unit through integration in the cover as Powerturn F/R-IS/TS variant

Variant Invers



With GC 342 laser scanner, experimenta, Heilbronn, Germany (photo: Jürgen Pollak / GEZE GmbH)

**Swing door systems for smoke and heat extraction fresh air solutions
as well as doors along escape and rescue routes**

AREAS OF APPLICATION

- Use in the Slimdrive EMD-F product family
- Suitable for escape and rescue routes and for smoke and heat extraction fresh air opening systems
- For single leaf right and left single-action doors

PRODUCT FEATURES

- Doors are opened by spring force and closed motor-driven
- If there is a power failure or fire alarm, the door is securely opened
- No emergency power supply needed

Variant EN7



With GC 338 sensor strips (photo: GEZE GmbH)

Swing door systems for large and heavy as well as highly frequented doors

AREAS OF APPLICATION

- Use in the Powerturn product family
- Automation of very large and heavy swing doors
- For right and left single-action doors

PRODUCT FEATURES

- Drive variants with closing force EN7 are approved for fire protection doors in the F design
- Fire protection doors up to 600 kg leaf weight or 1600 mm leaf width can be realised
- Slim drive design to meet the highest demands in terms of appearance

Accessible toilet

Accessible toilets must be designed in such a way that people with all sorts of different handicaps can use the facilities without needing help. GEZE swing door drives provide an indispensable service for this application, and guarantee a high level of convenience.

FUNCTIONAL DESCRIPTION

The non-contact proximity switch is installed at hand height and detects persons and objects at a distance of 10 to 60 cm (adjustable). Approaching the switch is sufficient to open the door. When the "internal switch" is triggered with the door closed, the system switches into the exit only mode of operation, meaning the outer switch on the door can no longer open. Both proximity switches switch from green to red and signal that the WC is occupied. The drive uses motor power to hold the door in the closed position. Triggering the "internal switch" again switches the mode of operation back to automatic. Both proximity switches switch from red to green. The door opens and the "external push button" is cleared again.

An optional pull switch can be used to transmit a message to an alarm system. If the WC is occupied for longer than 30 minutes, a message is also transmitted to an alarm system or an optional audio alert.

In the event of a power failure, the electric strike (fail-safe electric strike) releases and the user can leave the cubicle by pushing or pulling the door open. In emergencies, the door can be opened manually from the outside by means of a key, or by triggering the emergency shut-off switch.



1 = Swing door drive | 2 = Emergency shut-off switch (recommended installation height: 1600 mm) | 3 = Non-contact proximity switch (flush-mounted) | 4 = Non-contact proximity switch (surface-mounted) | 5 = Pull switch emergency call | 6 = Laser scanner



Slimdrive EMD-F swing door drive with GC 338 sensor strip, VGH Versicherungen Hanover (photo: Lothar Wels / GEZE GmbH)



SWING DOOR

Swing door drives

Make life easier for yourself and others – with GEZE swing door drives. Depending on your needs, our selection of products will offer you the right solution. Our electromechanical swing door drives are suitable for doors of up to 600 kg with a high frequency of public traffic. An electromechanical drive, which functions extremely quietly and also visually fits perfectly into the conditions of the door with its compact dimensions, is ideal for front doors and internal application.



ECTurn



Electromechanical swing door drive for barrier-free single leaf doors up to 125 kg

AREAS OF APPLICATION

- Right and left single leaf single-action doors
- Single-action doors up to 1100 mm leaf width or 125 kg weight
- Entrance and interior doors with moderate access frequency
- Automation of frameless all-glass doors
- Door leaf installation and transom installation
- Barrier-free access

PRODUCT FEATURES

- Opening and closing speed can be individually adjusted
- Electrical latching action which accelerates the door shortly before the closed position
- Low-energy function opens and closes the door with reduced speed, fulfilling the highest safety demands
- Obstacle detection detects an obstacle through contact and stops the opening or closing process
- Automatic reversing detects an obstacle and returns to the opening position
- Push & Go function triggers the automatic drive components following light manual pressure on the door leaf
- Drive can be used with guide rail or link arm
- Push to close function enables the opened door to be closed automatically by means of slight manual pressure
- Glass guide rail available for use on glass doors with a glass thickness of 8-10 mm
- Optional rechargeable battery provides maximum safety during a power failure
- Optional radio board for wireless activation by radio transmitter

TECHNICAL DATA

Ecturn	
PRODUCT FEATURES	
Height	60 mm
Width	580 mm
Depth	60 mm
Leaf weight (max.) single leaf	125 kg
Leaf width (min.-max.)	650 – 1100 mm
Reveal depth (max.)*	200 mm
Door overlap (max.)*	50 mm
Drive type	Electromechanical
Door opening angle (max.)*	110°
DIN left	●
DIN right	●
Transom installation opposite hinge side with link arm	●
Transom installation opposite hinge side with guide rail	●
Transom installation opposite hinge side with guide rail on all-glass doors	●
Transom installation hinge side with guide rail on all-glass doors	●
Transom installation hinge side with guide rail	●
Door leaf installation opposite hinge side with guide rail	●
Door leaf installation hinge side with guide rail	●
Door leaf installation hinge side with link arm	●
Electrical latching action	●
Disconnection from mains	Main switch in the drive
Activation delay (max.)	20 s
Operating voltage	110 – 230 V
Frequency of supply voltage	50 – 60 Hz
Capacity rating	75 W
Power supply for external consumers (24 V DC)	600 mA
Temperature range**	-15 – 50° C
IP rating	IP20
Modes of operation	off, automatic, hold open, night
Type of function	Fully automatic
Automatic function	●
Low-energy function	●
Function keys	●
Obstacle detection	●
Automatic reversing	●
Push to close function	●
Push & Go	adjustable
Operation	Programme switch TPS, programme switch integrated into the drive, programme switch DPS
Parameter setting	Programme switch DPS, control unit
Approvals	EN 16005

● = Yes | * = Depending on type of installation | ** = The drive is designed exclusively for use in dry rooms.

→ **Note:** The maximum possible leaf weight in relation to leaf width can be found in the chapter on areas of application (charts).

AREAS OF APPLICATION



Note:



Low-energy mode without protection should only be considered if the risk assessment for people in special need of protection has shown that the risk to these users is low. If there is a potential risk, then the hazardous area, such as the rotation range and the secondary closing edge, must be protected using additional safety measures.

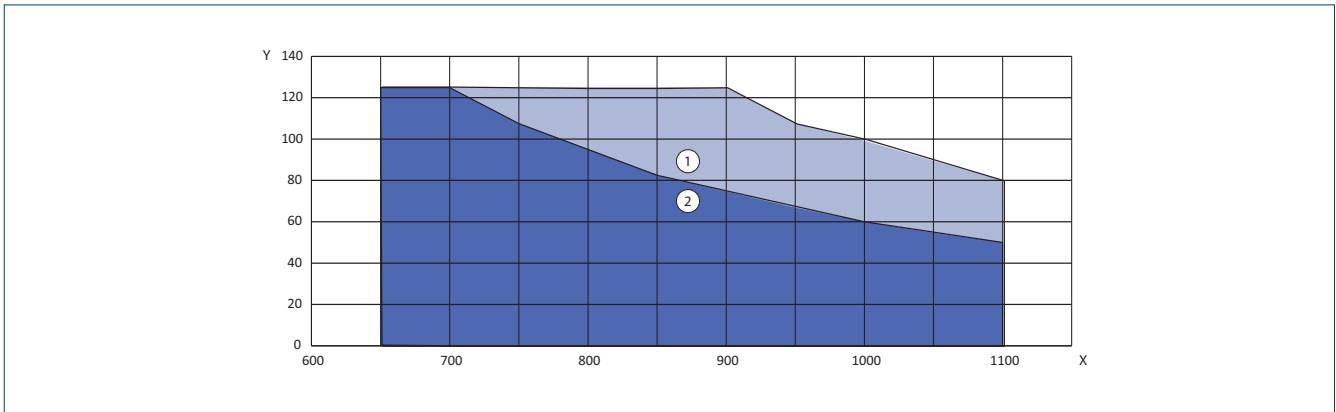

X = Door width (mm) | Y = Door weight (kg) | 1 = Area of application in low-energy mode | 2 = Area of application in automatic mode



Ecturn (photo: Studio BE / GEZE GmbH)

PRODUCT SCALE DRAWING

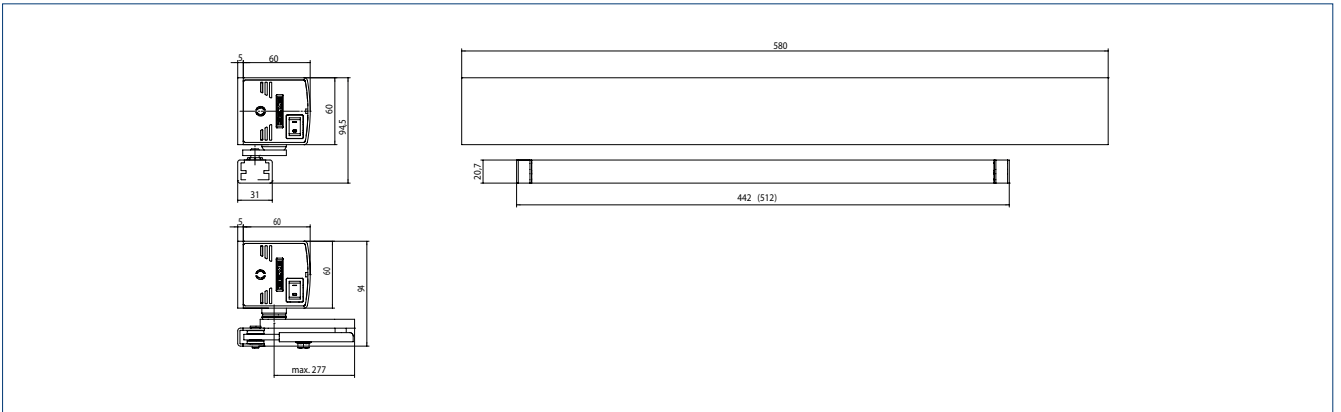

Ecturn

→ **Note:** Illustration shows DIN left, DIN right is mirror-inverted.

TRANSOM INSTALLATION WITH GUIDE RAIL ON THE HINGE SIDE, SINGLE LEAF

Reveal depth (max.) 40 mm
 Door overlap (max.) 40 mm

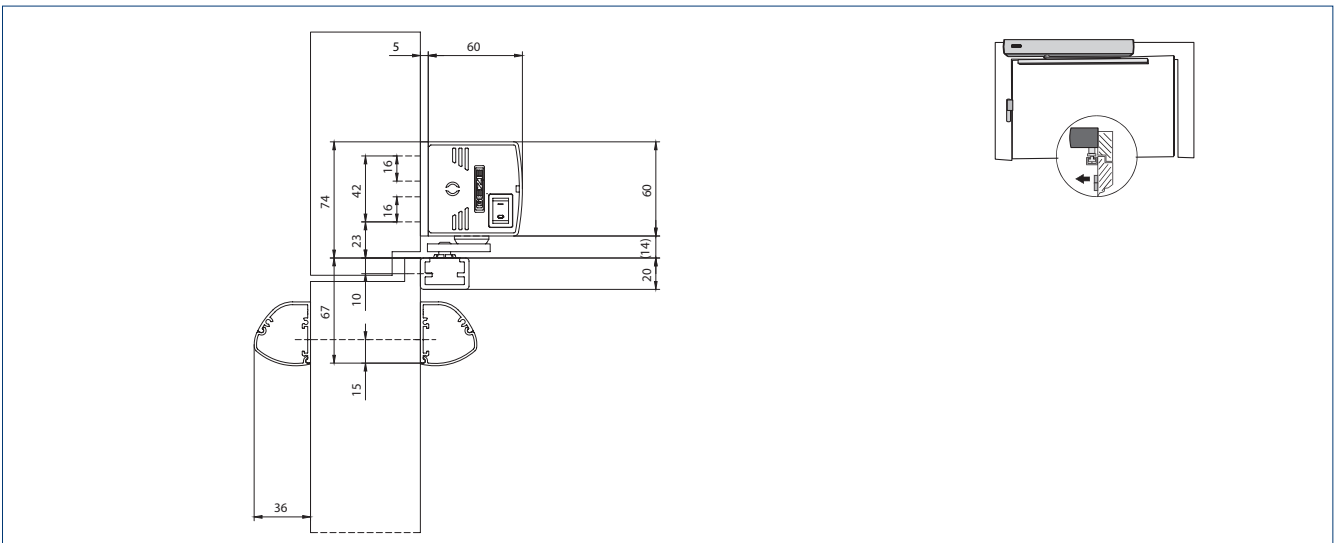

Ecturn with GC 338

INSTALLATION WITH MOUNTING PLATE (A) AND DIRECT INSTALLATION (B)

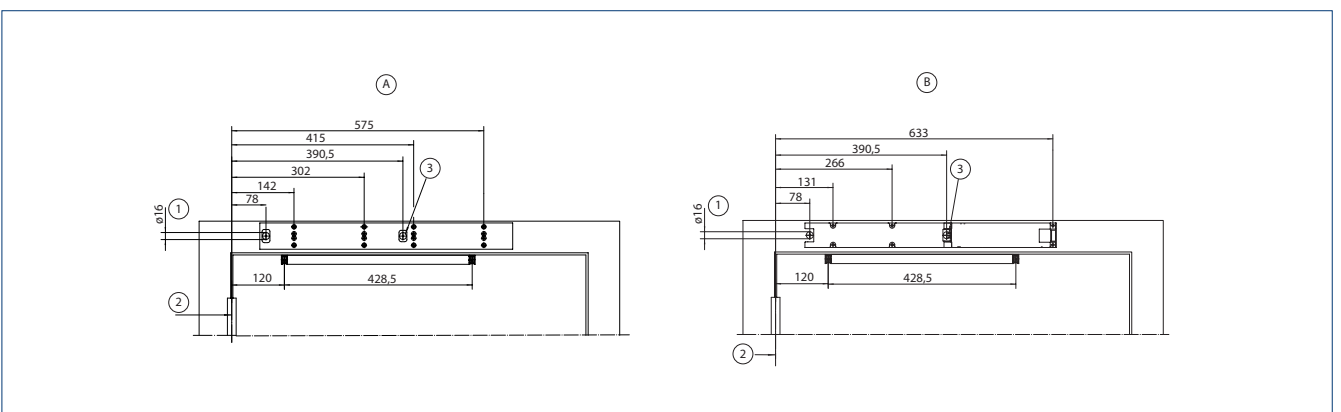

A = Installation with mounting plate | B = Direct installation | 1 = Concealed line-feed for low-voltage connection and mains cable | 2 = Dimensional reference centre of hinge | 3 = Concealed line-feed for low-voltage connection

TRANSOM INSTALLATION WITH GUIDE RAIL ON THE OPPOSITE HINGE SIDE, SINGLE LEAF

Reveal depth (max.) 30 mm

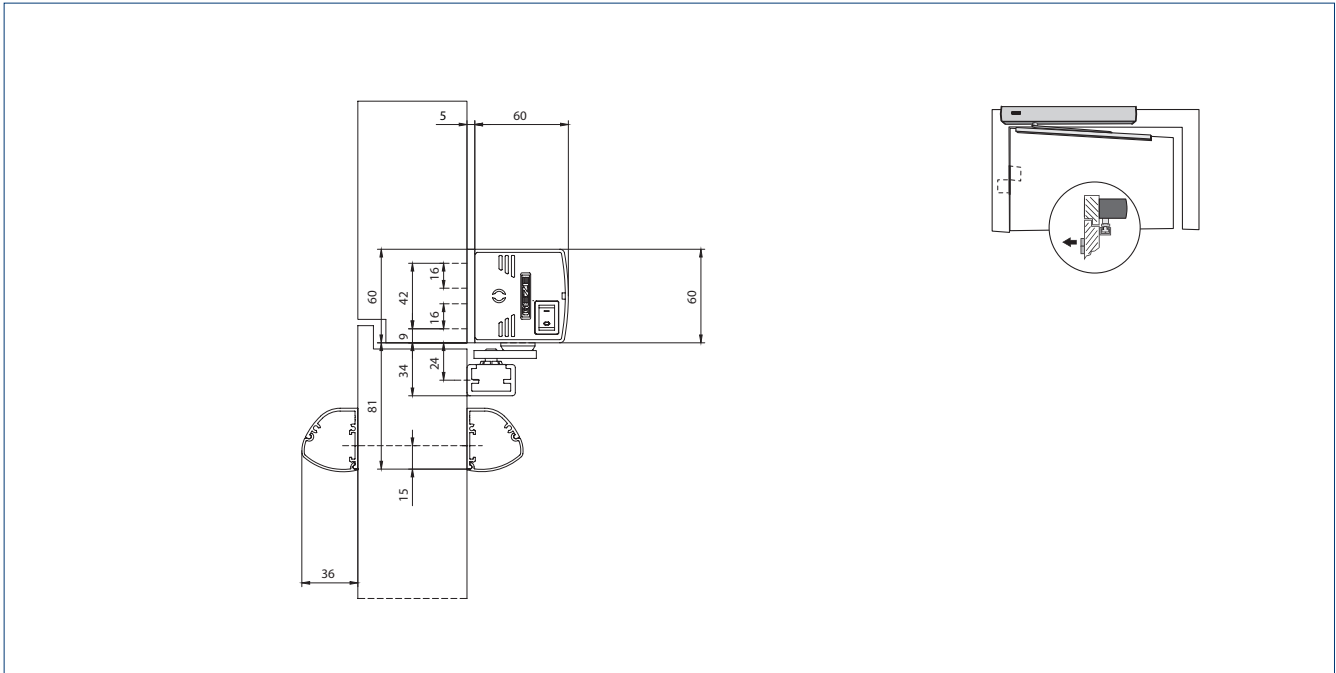

ECTurn with GC 338

INSTALLATION WITH MOUNTING PLATE (A) AND DIRECT INSTALLATION (B)

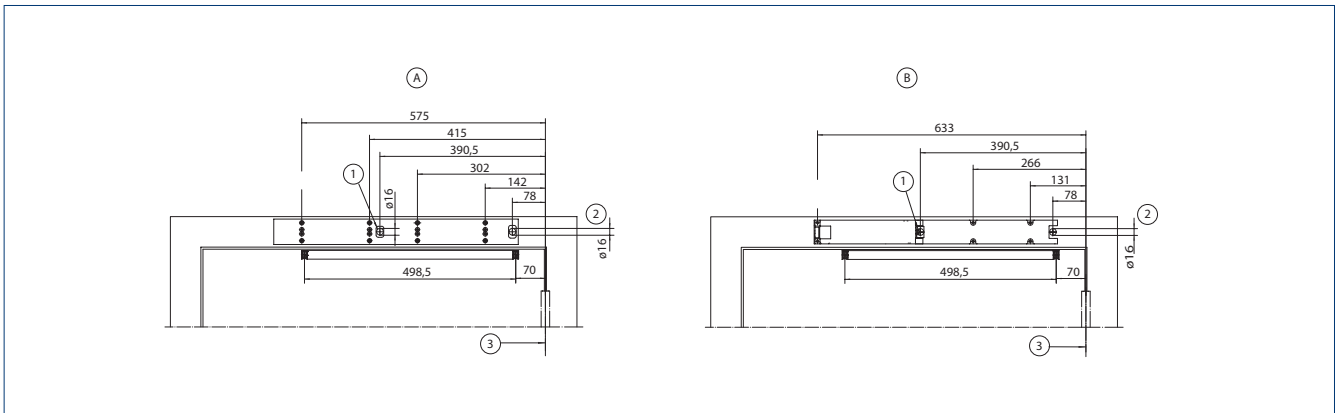

A = Installation with mounting plate | B = Direct installation | 1 = Concealed line-feed for low-voltage connection | 2 = Concealed line-feed for low-voltage connection and mains cable | 3 = Dimensional reference centre of hinge

TRANSOM INSTALLATION WITH LINK ARM ON THE OPPOSITE HINGE SIDE, SINGLE LEAF

Reveal depth (max.) 200 mm

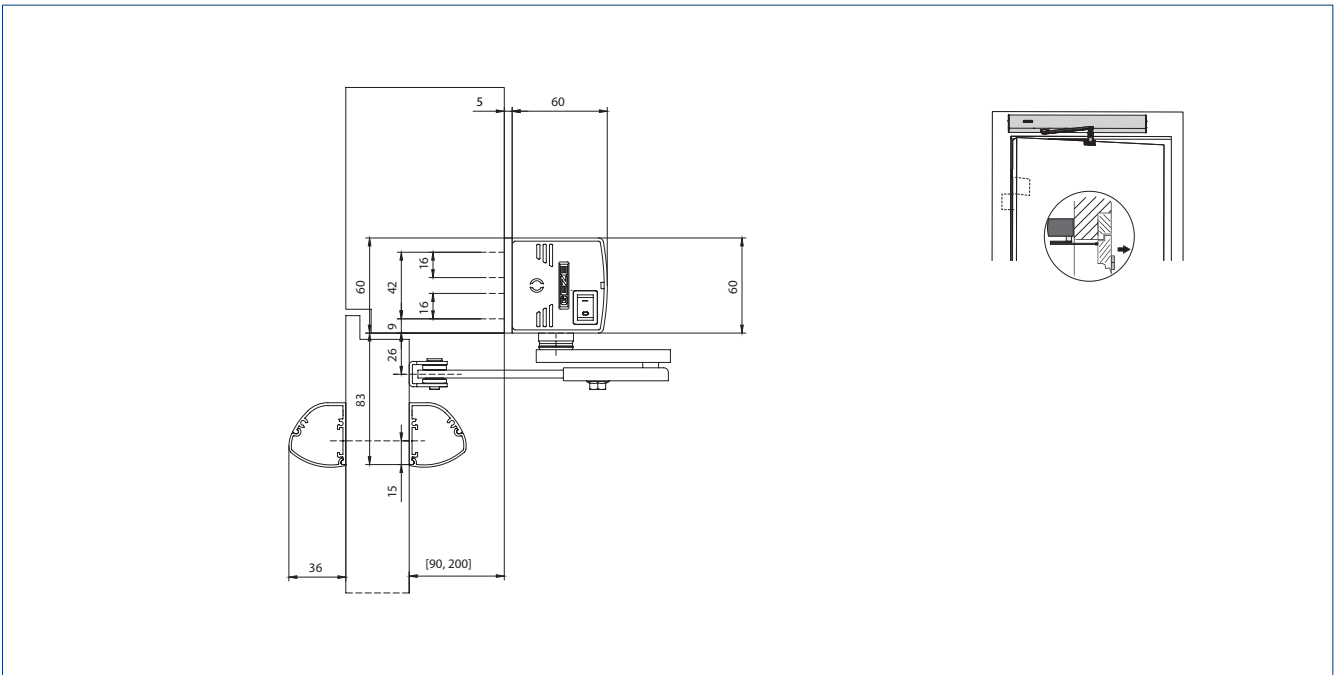

Ecturn with GC 338

INSTALLATION WITH MOUNTING PLATE (A) AND DIRECT INSTALLATION (B)

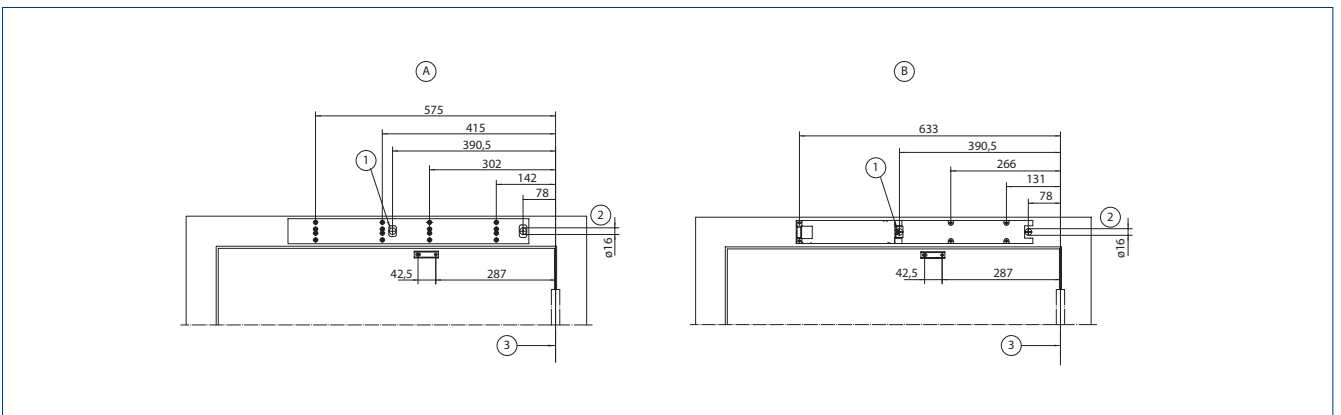

A = Installation with mounting plate | B = Direct installation | 1 = Concealed line-feed for low-voltage connection | 2 = Concealed line-feed for low-voltage connection and mains cable | 3 = Dimensional reference centre of hinge

DOOR LEAF INSTALLATION WITH GUIDE RAIL ON THE HINGE SIDE, SINGLE LEAF

Door overlap (max.) 50 mm

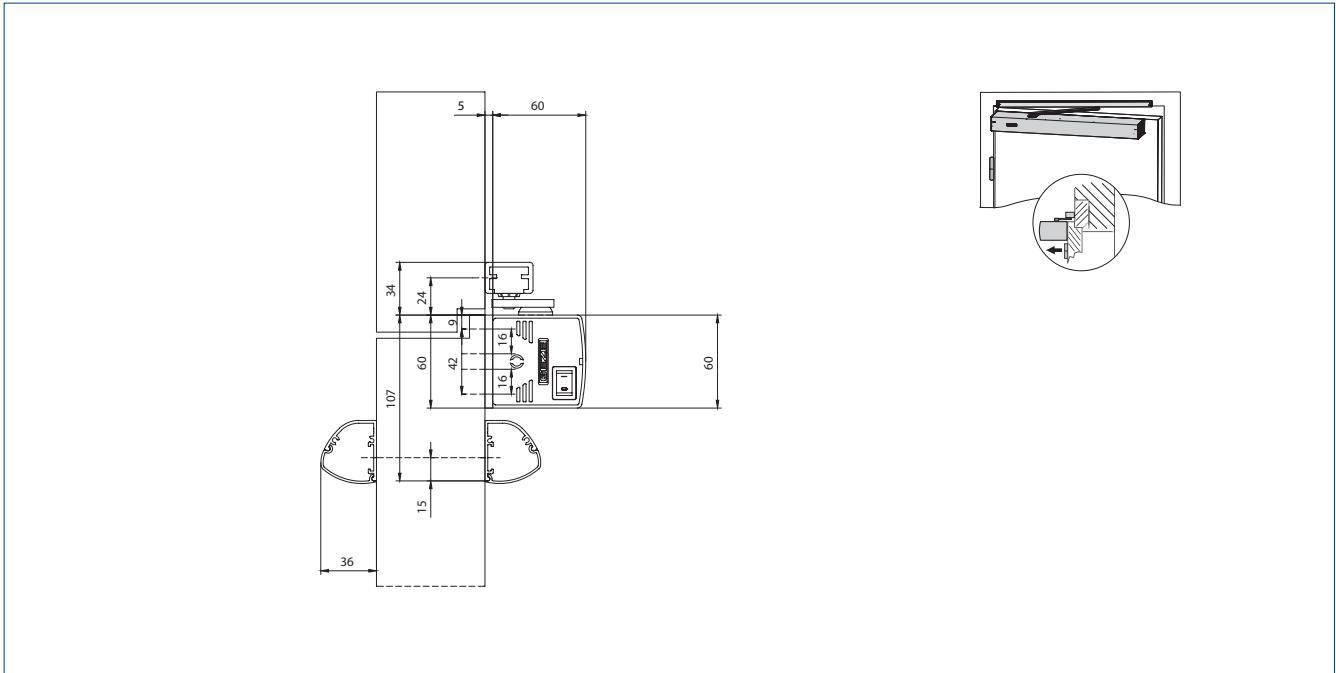

ECTurn with GC 338

INSTALLATION WITH MOUNTING PLATE (A) AND DIRECT INSTALLATION (B)

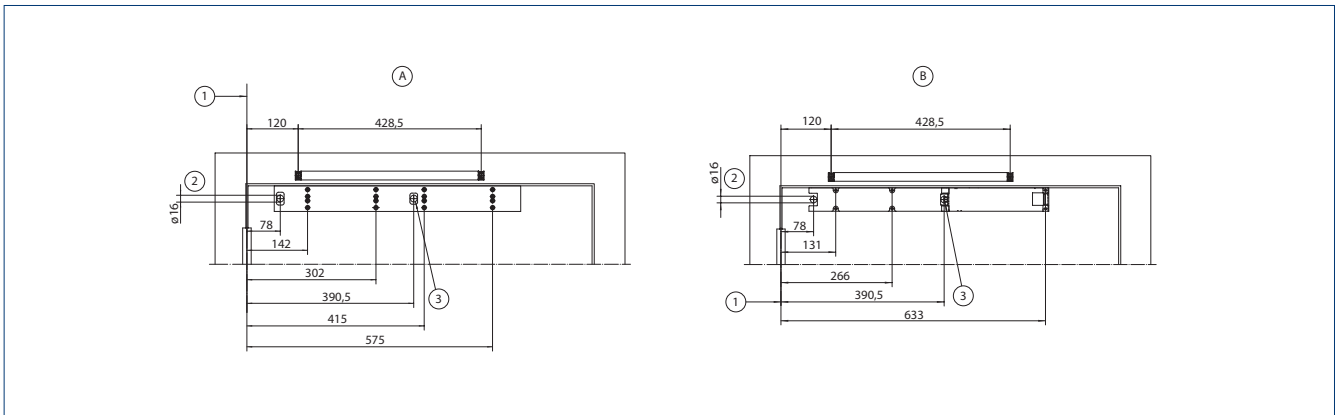

A = Installation with mounting plate | B = Direct installation | 1 = Dimensional reference centre of hinge | 2 = Concealed line-feed for low-voltage connection and mains cable | 3 = Concealed line-feed for low-voltage connection

DOOR LEAF INSTALLATION WITH LINK ARM ON THE HINGE SIDE, SINGLE LEAF

Door overlap (max.) 200 mm

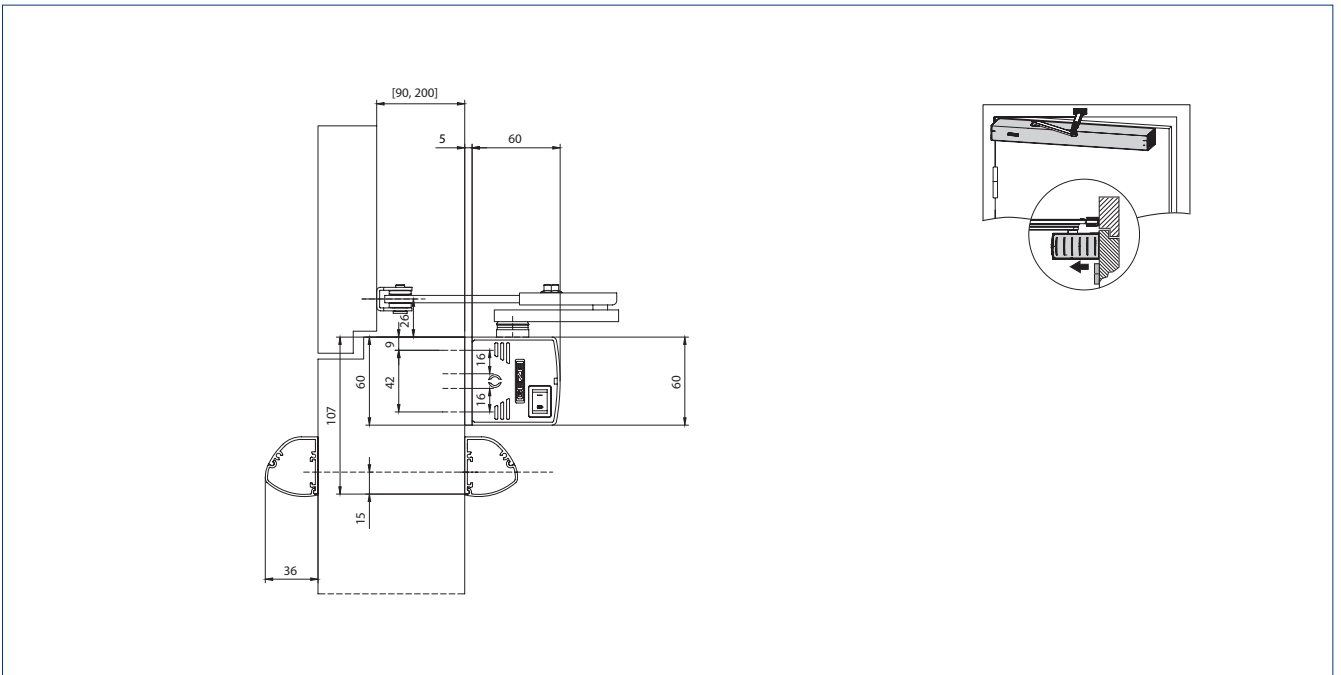

Ecturn with GC 338

INSTALLATION WITH MOUNTING PLATE (A) AND DIRECT INSTALLATION (B)

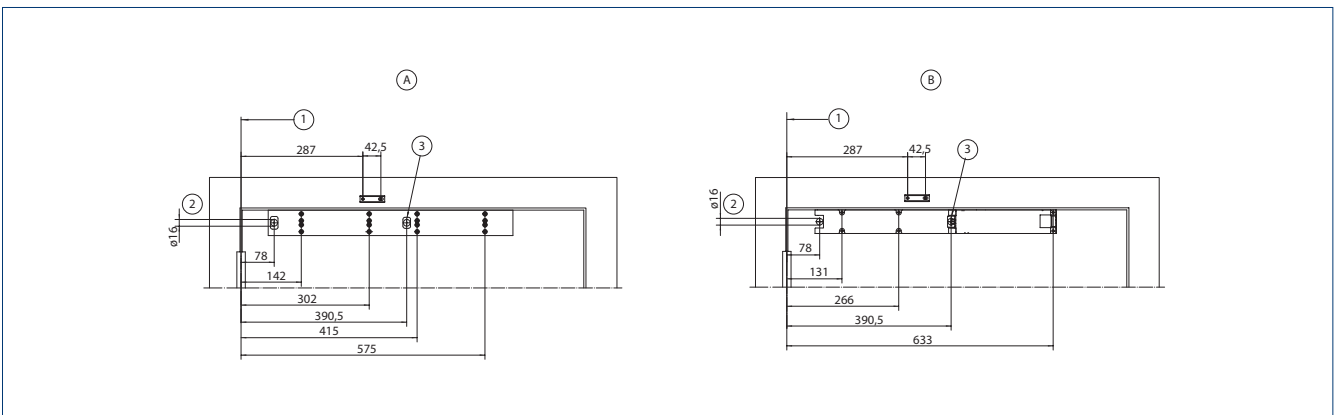

A = Installation with mounting plate | B = Direct installation | 1 = Dimensional reference centre of hinge | 2 = Concealed line-feed for low-voltage connection and mains cable | 3 = Concealed line-feed for low-voltage connection

DOOR LEAF INSTALLATION WITH GUIDE RAIL ON THE OPPOSITE HINGE SIDE, SINGLE LEAF

Reveal depth (max.) 20 mm

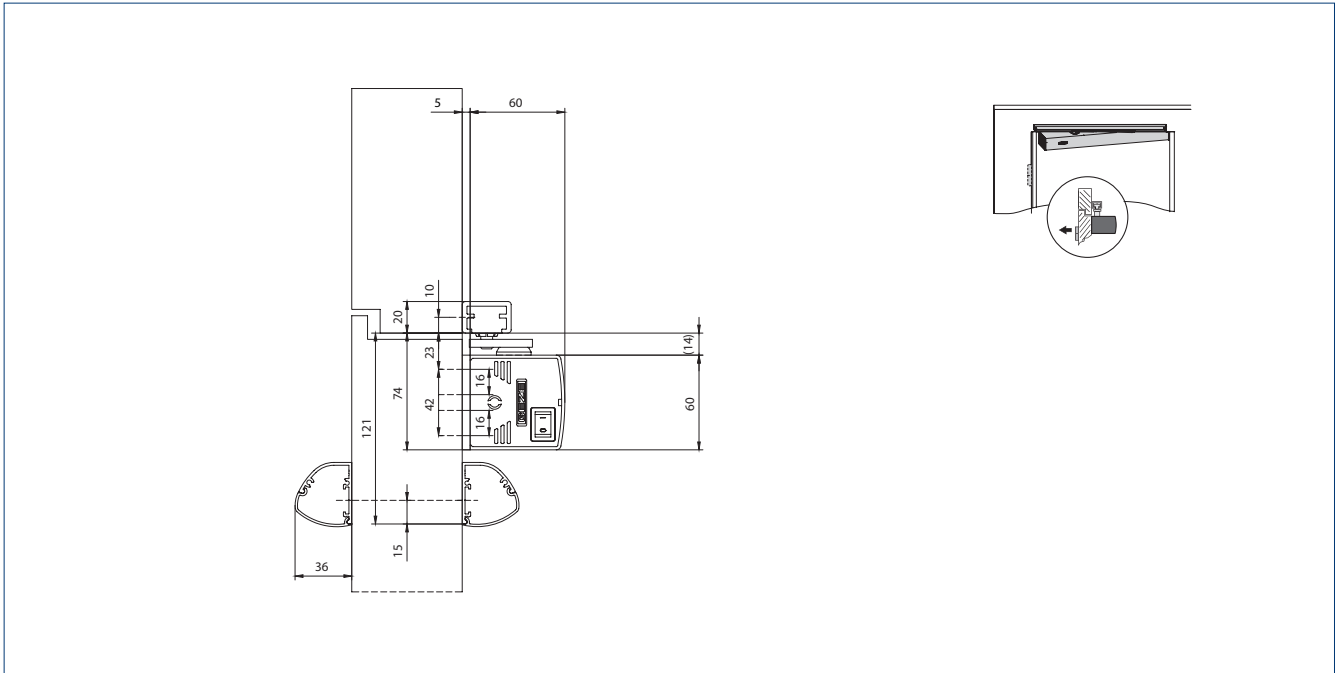

ECTurn with GC 338

INSTALLATION WITH MOUNTING PLATE (A) AND DIRECT INSTALLATION (B)

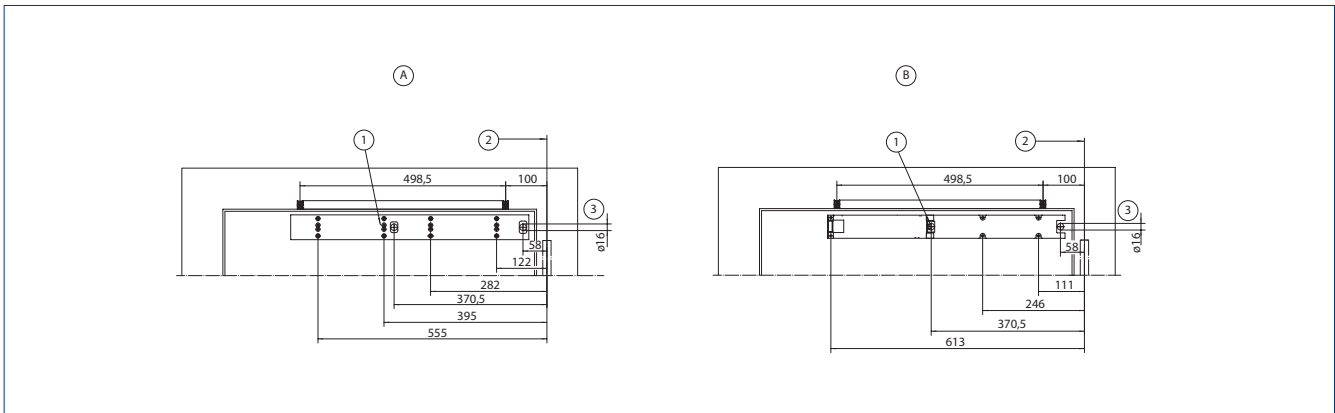

A = Installation with mounting plate | B = Direct installation | 1 = Concealed line-feed for low-voltage connection | 2 = Dimensional reference centre of hinge | 3 = Concealed line-feed for low-voltage connection and mains cable

TRANSOM INSTALLATION WITH GLASS GUIDE RAIL ON THE HINGE SIDE

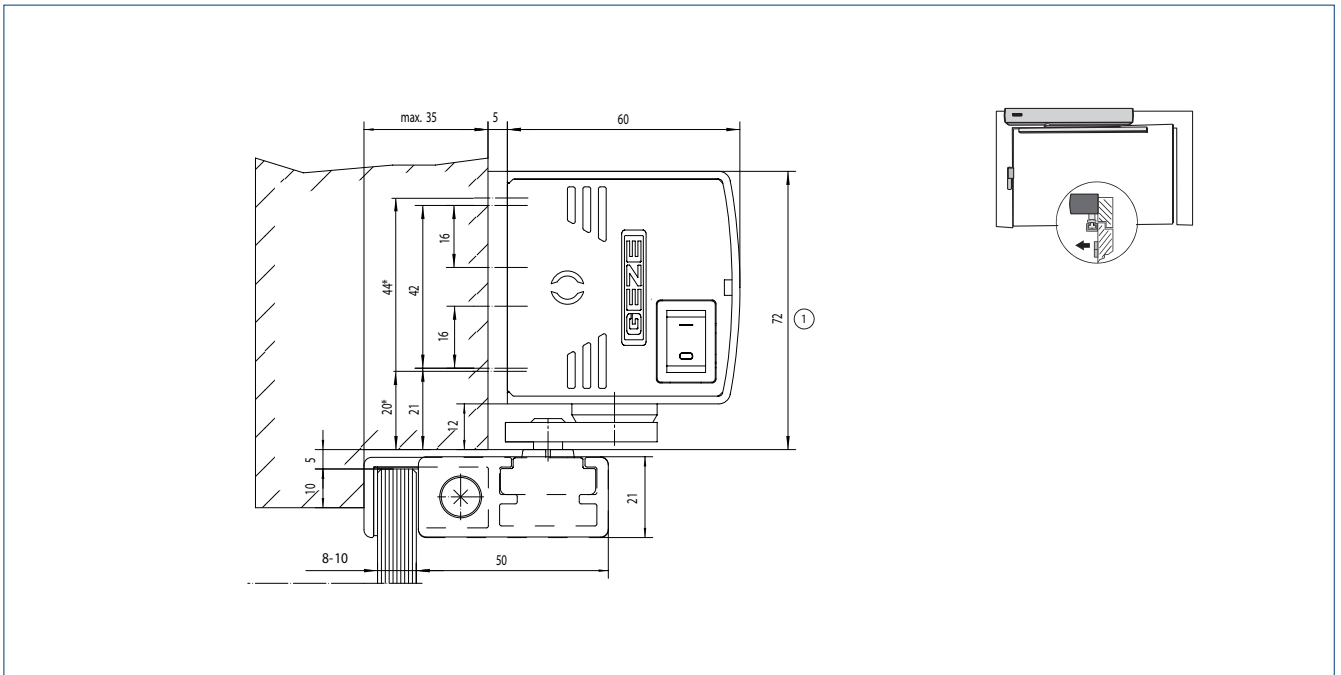

* = Direct installation | 1 = Space needed for Ecturn

INSTALLATION WITH MOUNTING PLATE (A) AND DIRECT INSTALLATION (B)

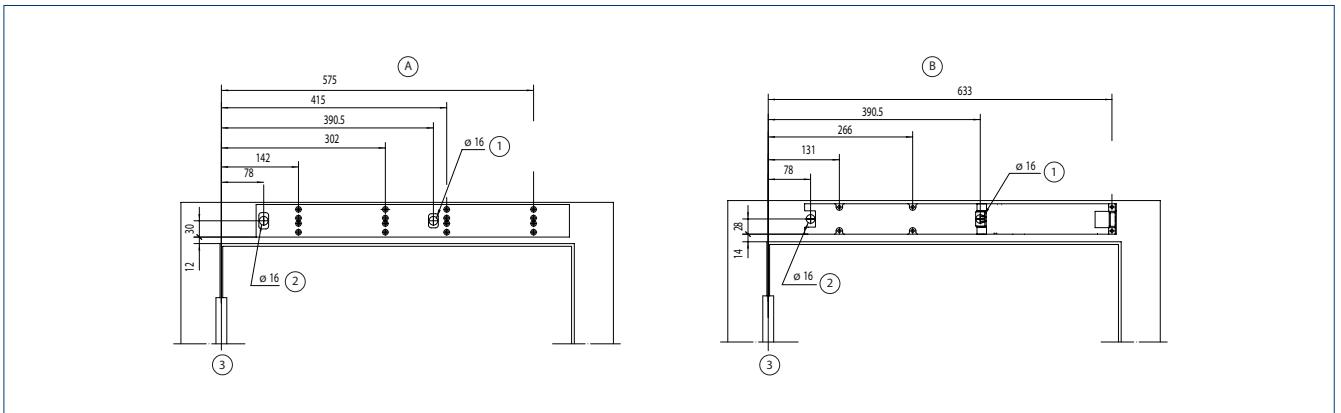

A = Installation with mounting plate | B = Direct installation | 1 = Concealed line-feed for low-voltage connection | 2 = Concealed line-feed for low-voltage connection and mains cable | 3 = Dimensional reference centre of hinge

TRANSOM INSTALLATION WITH GLASS GUIDE RAIL ON THE OPPOSITE HINGE SIDE

Drawing no. 70107-ep19

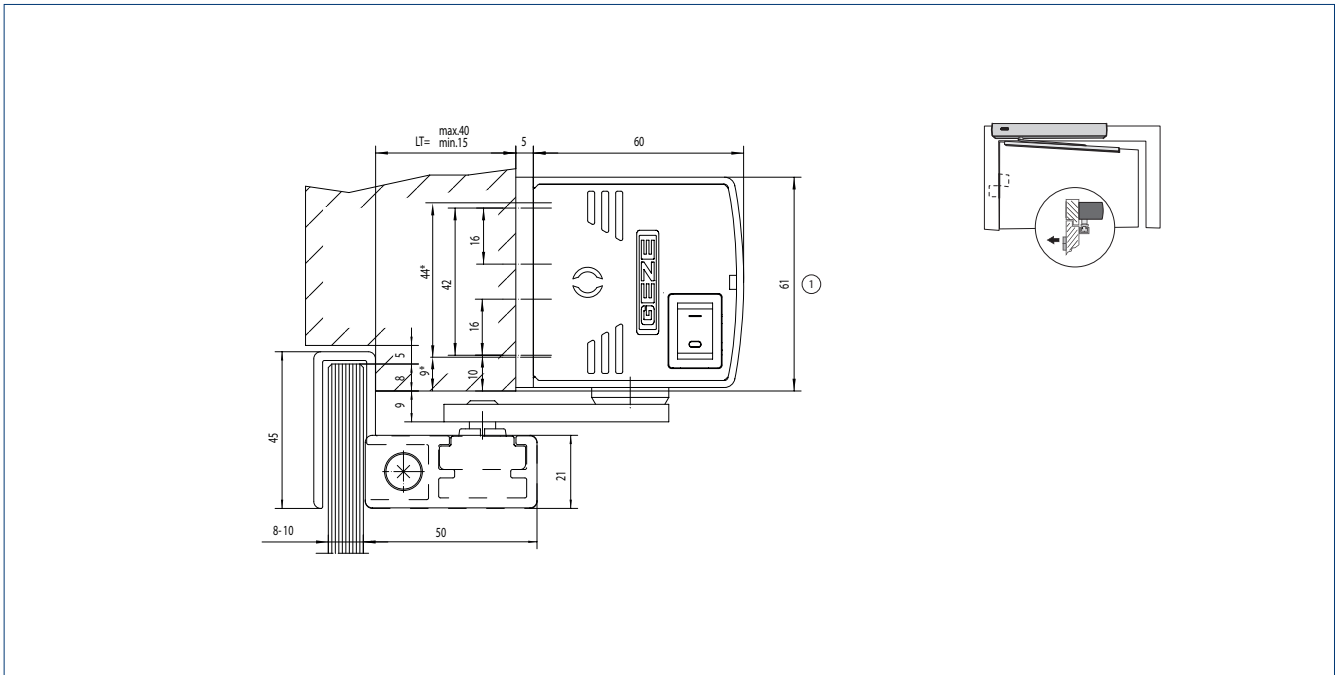

* = Direct installation | 1 = Space needed for ECTurn | LT = Reveal depth

INSTALLATION WITH MOUNTING PLATE (A) AND DIRECT INSTALLATION (B)

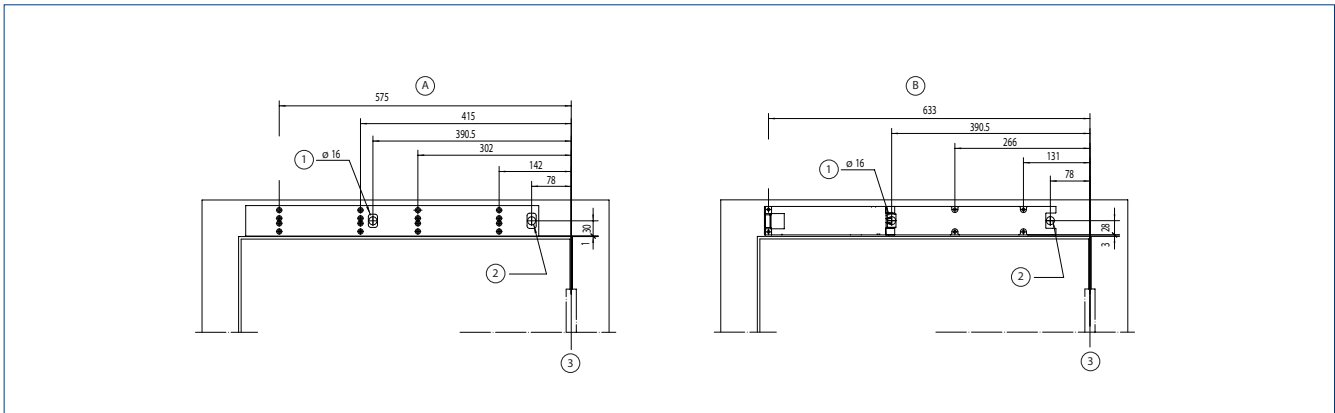

A = Installation with mounting plate | B = Direct installation | 1 = Concealed line-feed for low-voltage connection | 2 = Concealed line-feed for low-voltage connection and mains cable | 3 = Dimensional reference centre of hinge

LEGEND FOR THE CABLE PLANS

CABLES

- 1 = NYM-J 3 × 1.5 mm²
- 2 = J-Y(ST)Y 1 × 2 × 0.6 LG
- 3 = J-Y(ST)Y 2 × 2 × 0.6 LG
- 4 = J-Y(ST)Y 4 × 2 × 0.6 LG
- 5 = LiYY 2 × 0.25 mm²
- 6 = LiYY 4 × 0.25 mm²
- 7 = Scope of supply sensor strip or LiYY 5 × 0.25 mm²
- 8 = Route empty pipe with pull-wire inner diameter 10 mm

ABBREVIATIONS

HS	Main switch
NOT	Emergency stop switch
KB	Mechanical contact
PS	Programme switch
ST	Emergency stop button
KI	Contact sensor inside
KA	Contact sensor outside
TOE	Electric strike
RM	Bolt message



Notes:



- Cable plans can also be prepared for specific projects after receipt of order
- Version of standard cable plans in accordance with GEZE specifications
- Wiring in accordance with VDE 0100
- Allow the cable for the drive to project at least 1500 mm out of the wall

1 Door transmission cable (included in the scope of supply for sensor strip) | 2 Cable exit for drive unit see installation drawings for Ecturn 70107-ep01 to -ep06 | 3 Cable included in the scope of supply for the sensor | 4 + 5 Connection box for power supply circuit and control cable combined on site. Power supply circuit and control cable must be wired in separate terminal spaces. | 4 Mains connection box W×H×D min. 65 × 65 × 57 | 5 Control cable box W×H×D min. 94 × 65 × 57 with PG-11 duct

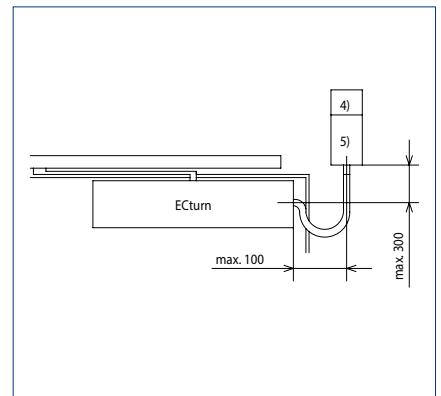
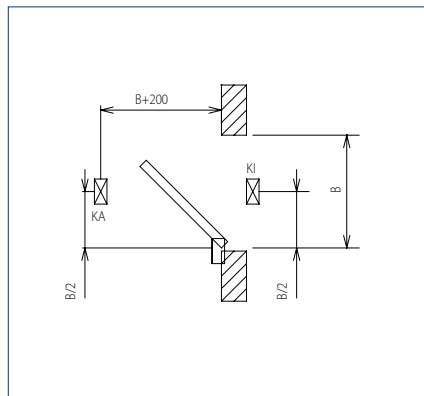
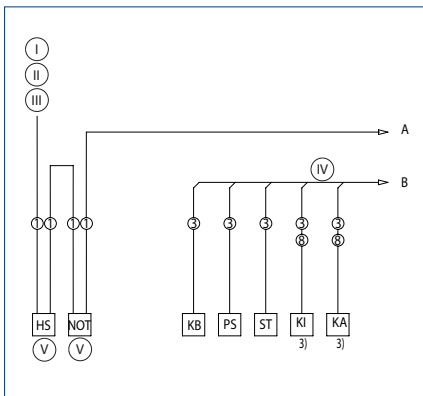

I = Power supply circuit 230 V / 50 Hz |
 II = Safety fuse 10 A | III = Connection value 230 W 1 A |
 IV = And / Or | V = Option

SINGLE LEAF

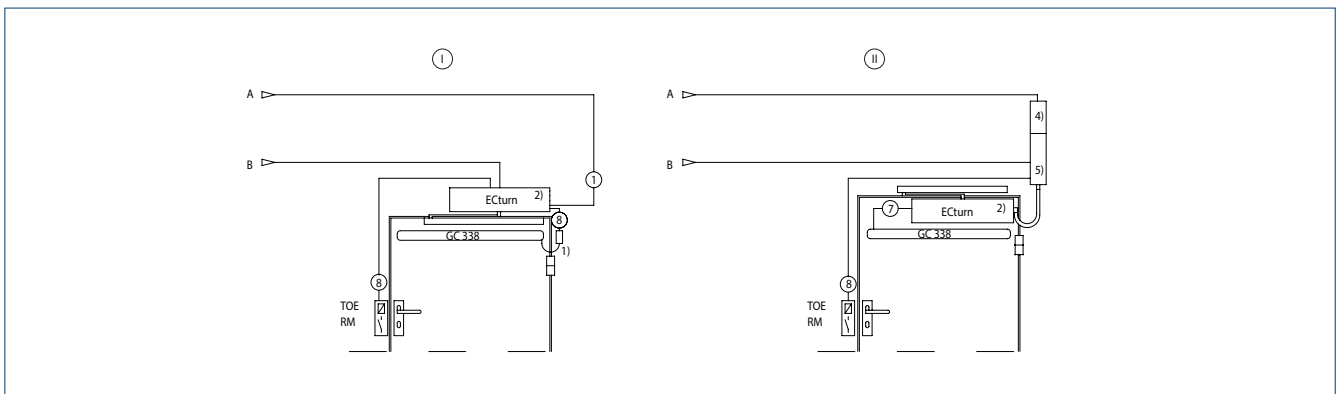

I = Transom installation concealed line-feed | II = Door leaf installation

ECturn Inside



**Integrable electromechanical swing door drive
for barrier-free single leaf doors up to 125 kg**

AREAS OF APPLICATION

- Right and left single leaf single-action doors
- Single-action doors up to 1100 mm leaf width or 125 kg weight
- Entrance and interior doors with moderate access frequency
- For door leaf thicknesses from 55 mm
- Integrated installation in door leaf or frame
- Barrier-free access

PRODUCT FEATURES

- Drive is embedded in door leaf or frame and fulfils maximum design requirements
- Opening and closing speed can be individually adjusted
- Electrical latching action which accelerates the door shortly before the closed position
- Low-energy function opens the door with reduced speed, fulfilling the highest safety requirements
- Obstacle detection detects an obstacle through contact and stops the opening or closing process
- Automatic reversing detects an obstacle and returns to the opening position
- Push & Go function triggers the automatic drive components following light manual pressure on the door leaf
- Push to close function enables the opened door to be closed automatically by means of slight manual pressure
- Drive is used with guide rail
- Optional rechargeable battery provides maximum safety during a power failure
- Optional radio board for wireless activation by radio transmitter

TECHNICAL DATA

ECTurn Inside

PRODUCT FEATURES

Height	61 mm
Width	566 mm
Depth	45 mm
Leaf weight (max.) single leaf	125 kg
Leaf width (min.-max.)	700 – 1100 mm
Drive type	Electromechanical
Door opening angle (max.)*	110°
DIN left	●
DIN right	●
Installation in the door leaf	●
Installation in the door frame	●
Electrical latching action	●
Activation delay (max.)	20 s
Supply voltage	Power supply: 110 – 230 V
Operating voltage	Drive: 24.5 – 30 V DC
Capacity rating	92 W
Power supply for external consumers (24 V DC)	600 mA
Temperature range	-15 – 50° C
IP rating	IP20
Modes of operation	off, automatic, hold open, night
Type of function	Fully automatic
Automatic function	●
Low-energy function	●
Function keys	●
Obstacle detection	●
Automatic reversing	●
Push to close function	
Push & Go	adjustable
Operation	Programme switch integrated in the drive, programme switch TPS, programme switch DPS
Parameter setting	Control unit, programme switch DPS
Approvals	EN 16005

● = Yes | * = Depending on type of installation

→ **Note:** The maximum possible leaf weight in relation to leaf width can be found in the chapter on areas of application (charts).

AREAS OF APPLICATION



Note:



Low-energy mode without protection should only be considered if the risk assessment for people in special need of protection has shown that the risk to these users is low. If there is a potential risk, then the hazardous area, such as the rotation range and the secondary closing edge, must be protected using additional safety measures.

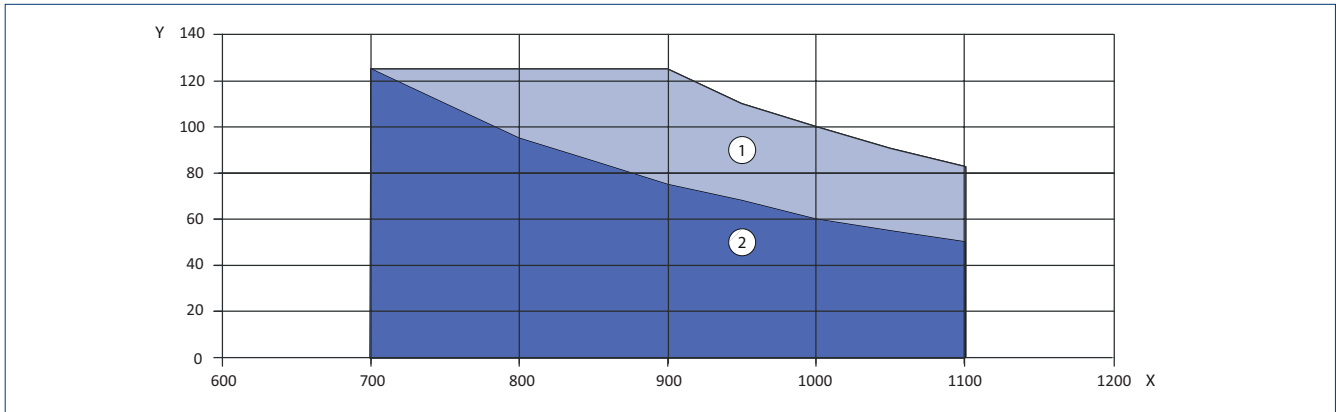

X = Door width (mm) | Y = Door weight (kg) | 1 = Area of application in low-energy mode | 2 = Area of application in automatic mode | Minimum door width for installation in metal door or frame 750 mm

PRODUCT SCALE DRAWING

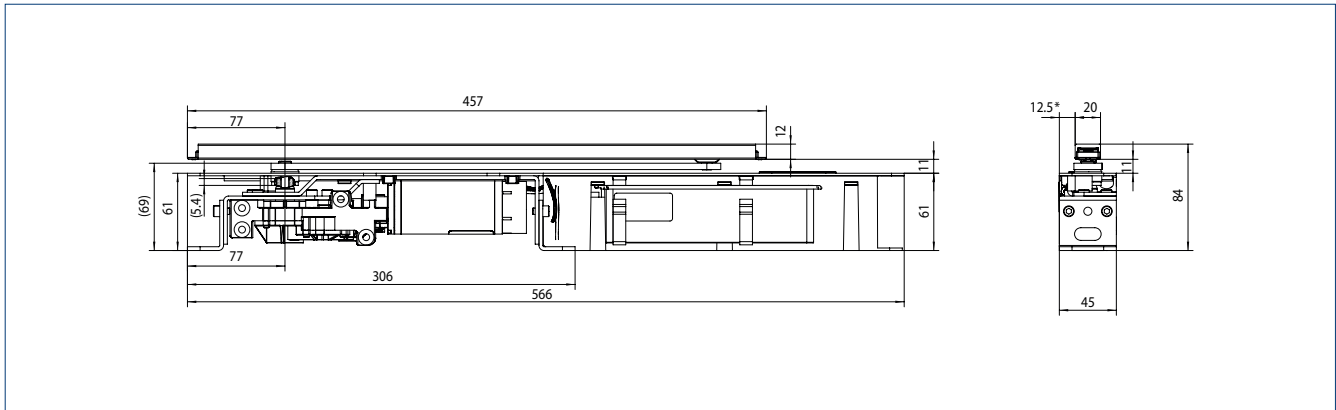

ECTurn Inside Representation of a wooden door leaf, mirror-inverted for door frames

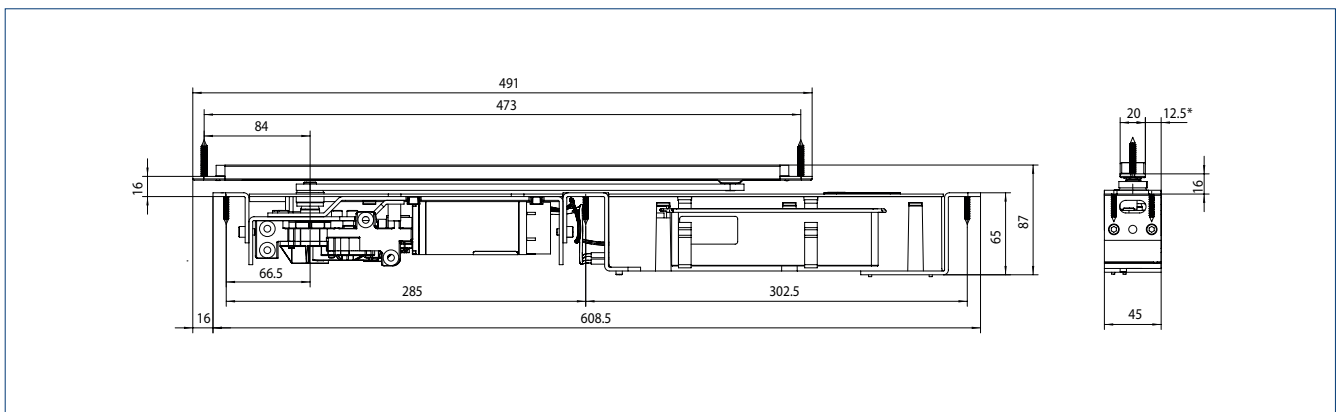

ECTurn Inside Representation of a metal door leaf, mirror-inverted for door frames

OVERVIEW OF COMPONENTS

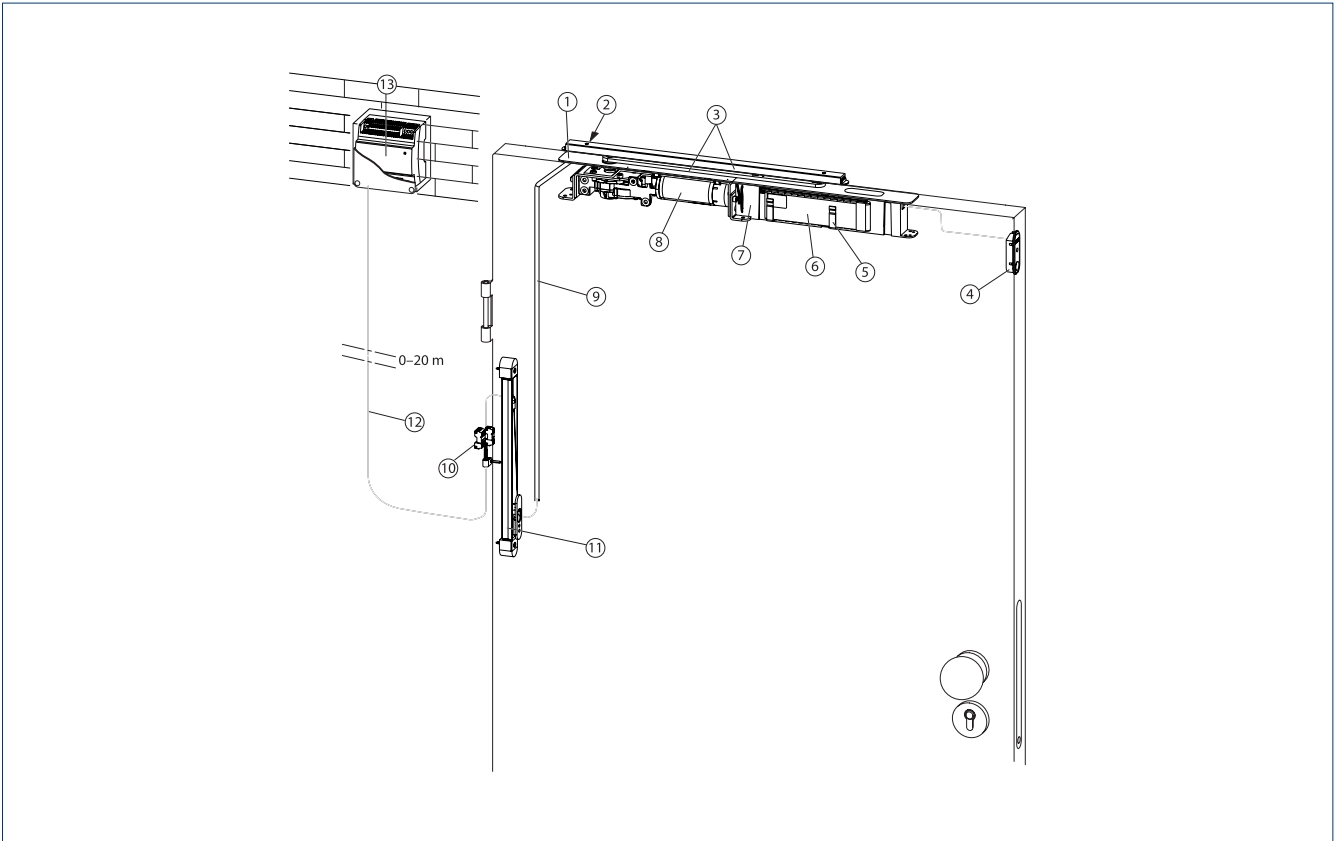

1 = Cover for motor gear unit | 2 = Back check | 3 = Guide rail and lever | 4 = Separate programme switch (optional) | 5 = Holder for rechargeable battery (optional) | 6 = Rechargeable battery (optional) | 7 = Control unit | 8 = Motor gear unit | 9 = Power supply cable, inside door 2.5 m | 10 = Electric installation material | 11 = Drip loop (optional) | 12 = Power supply cable (on site) | 13 = Power supply (flush-mounted installation)

INSTALLATION IN THE WOODEN DOOR LEAF

Drawing no. 70107-ep10

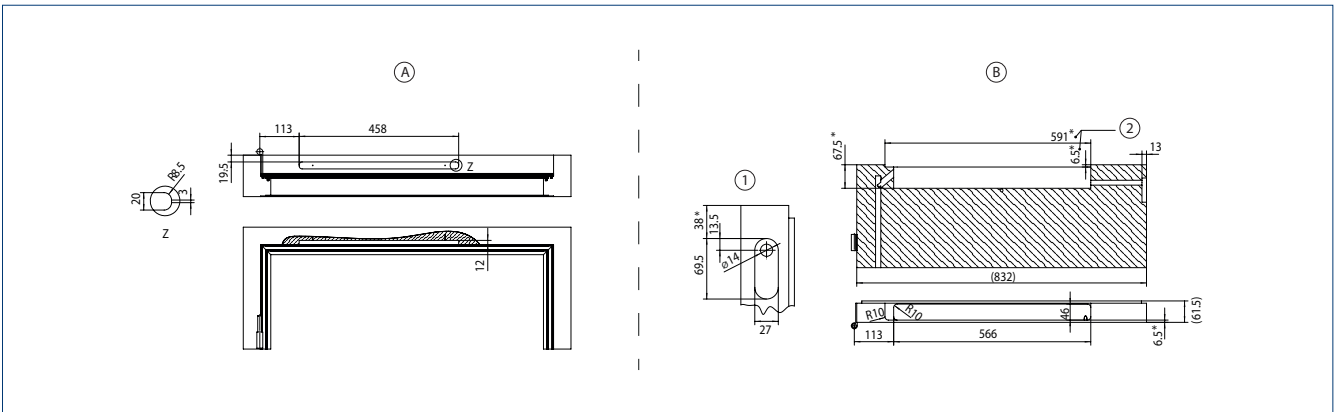

A = Frame cut-out | B = Door cut-out | 1 = Cut-out for programme switch (optional) | 2 = Cut-out for lever | * = Dimensions or positions may deviate depending on the door type.

LEGEND FOR THE CABLE PLAN

CABLES

1 = NNYM-J 3x1.5 mm ²	16 = Empty pipe Ø 10 mm with pull-wire; J-Y(ST)Y 4x0.6mm LG
2 = JJ-Y(ST) Y 2x2x0.6 mm ²	17 = Empty pipe Ø 12 mm with pull-wire; NYM-O 2x1.5mm ²
10 = Empty pipe Ø 10 mm with pull-wire; cable supplied by GEZE, max. 3 m	18 = Cable supplied by GEZE, cable length max. 3 m
11 = Cable information must be provided on-site	i = Cable consolidation for control/activation devices (symbolic)
13 = J-Y(ST) Y 2x2x0.6 mm ² ; optional empty pipe Ø 10 mm with pull-wire	RSK = Lock switch contact



Notes:



- This cable plan is a simplified symbolic illustration. Connections must be taken from the wiring diagram. Cable routing is included in the VDE guidelines.
- Positioning of the activation and operating elements must be specified on site
- Positions shown with dashed lines are positioned on the opposite side
- In compliance with DIN 18650 / EN 16005 for automatic mode sensor strips on both sides

STANDARD CABLE PLAN MAXIMUM EXTENT, UNILATERALLY PULLING, SINGLE LEAF, DIN RIGHT

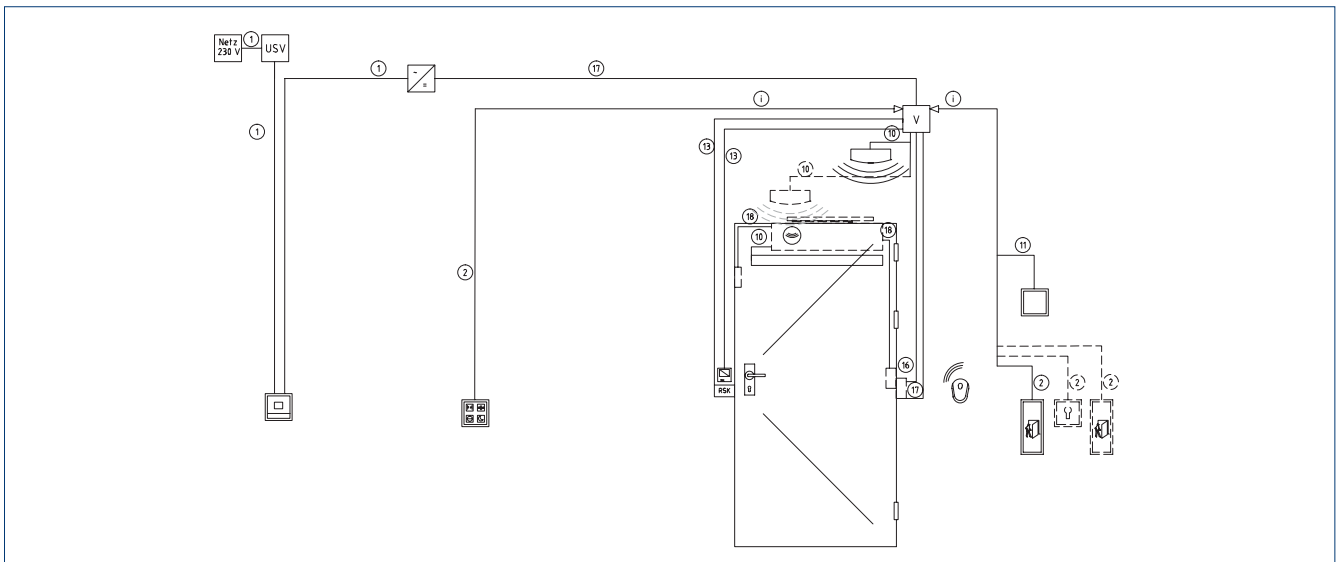

Front door, private residence, Stuttgart, Germany (photo: GEZE GmbH)

Slimdrive EMD



Electromechanical swing door drive
of only 7 cm height for single and double leaf doors weighing up to 230 kg

AREAS OF APPLICATION

- Single and double leaf right and left single-action doors
- Single-action doors up to 1400 mm leaf width or 230 kg weight
- Interior and exterior doors with high access frequency
- Door leaf installation and transom installation

PRODUCT FEATURES

- Opening and closing speed can be individually adjusted
- Electrical and mechanical latching action which accelerates the door shortly before the closed position
- Low-energy function opens and closes the door with reduced speed, fulfilling the highest safety demands
- Vestibule function controls the opening and closing of two consecutive doors (interlocking door system)
- Obstacle detection detects an obstacle through contact and stops the opening or closing process
- Automatic reversing detects an obstacle and returns to the opening position
- Push & Go function triggers the automatic drive components following light manual pressure on the door leaf
- Drive can be used with roller guide rail or link arm
- Freely configurable inputs and outputs for different functions
- Can be networked via CAN bus and integrated into building technology management systems

TECHNICAL DATA

	Slimdrive EMD	Slimdrive EMD-F	Slimdrive EMD-F-IS	Slimdrive EMD Invers
PRODUCT FEATURES				
Height	70 mm			
Width	650 mm			
Depth	121 mm			
Leaf weight (max.) single leaf	180 kg	230 kg		
Hinge clearance (min.-max.) double leaf	1500 – 2800 mm			
Leaf width (min.-max.)	750 – 1400 mm			
Reveal depth (max.)*	400 mm			
Door overlap (max.)*	50 mm			
Drive type	Electromechanical			
Door opening angle (max.)*	130°			
Spring pre-load**	-	EN4 – EN6		-
DIN left	●	●	●	●
DIN right	●	●	●	●
Transom installation opposite hinge side with link arm	●	●	●	●
Transom installation opposite hinge side with roller guide rail	●	●	●	●
Transom installation hinge side with roller guide rail	●	●	●	●
Door leaf installation hinge side with roller guide rail	●	●	-	●
Mechanical latching action	-	●	●	-
Electrical latching action	●	●	●	●
Electrical closing sequence control	●	●	●	●
Mechanical closing sequence control	-	-	●	-
Disconnection from mains	Main switch in the drive			
Activation delay (max.)	20 s			
Operating voltage	230 V			
Frequency of supply voltage	50 Hz			
Capacity rating	230 W			
Power supply for external consumers (24 V DC)	1000 mA			
Temperature range***	-15 – 50° C			
IP rating	IP20			
Modes of operation	Off, automatic, hold open, exit only, night			
Type of function	Fully automatic			
Automatic function	●	●	●	●
Low-energy function	●	●	●	-
Servo function	-	●	●	-
Function keys	●	●	●	●
Invers function (opening by spring force)	-	-	-	●
Vestibule function	●	●	●	●
Obstacle detection	●	●	●	●
Automatic reversing	●	●	●	●
Push & Go	adjustable			
Operation	Programme switch integrated on the drive unit, MPS, TPS, DPS			
Parameter setting	ST 220 service terminal, programme switch DPS, GEZEconnects (PC + Bluetooth)			
CAN interface	Optional			
Approvals	DIN 18650 EN 16005	DIN 18650 DIN 18263-4 EN 16005	DIN 18650 DIN 18263-4 Closing sequence controller tested acc. to EN 1158 EN 16005	DIN 18650 EN 16005
Suitable for fire protection doors	-	●	●	-
Integrated smoke switch (R variant)	-	●	●	-
Release and reset of the hold-open system	-	by push button	by push button	-

● = Yes | * = Depending on type of installation | ** = See torque overview table | *** = The drive is designed exclusively for use in dry rooms

→ **Note:** The maximum possible leaf weight in relation to leaf width can be found in the chapter on areas of application (charts).

OVERVIEW OF TORQUES SLIMDRIVE EMD-F

Type of installation	Transom installation hinge side (min.-max.)	Door leaf installation hinge side (min.-max.)	Transom installation opposite hinge side (min.-max.)	
Coupling element	Roller guide rail	Roller guide rail	Roller guide rail	Link arm
Spring pre-load closing force EN 1154	4 – 5	5	4 – 5	4 – 6
Closing torques	20 – 45 Nm	17 – 43 Nm	20 – 45 Nm	35 – 70 Nm
Opening torques, automatic	122 – 97 Nm	125 – 96 Nm	115 – 90 Nm	max. 150 Nm
Opening torques, manual	45 – 66 Nm	50 – 73 Nm	42 – 65 Nm	61 – 88 Nm

The doors must be fitted with suitable hinges for automatic operation. A door stopper is necessary.

EMD, EMD-F, EMD INVERS

Single leaf doors	Leaf width (min.)	Leaf width (max.)
Transom installation hinge side with roller guide rail	850 mm	1250 mm / 1400 mm*
Transom installation opposite hinge side with roller guide rail	850 mm	1250 mm / 1400 mm*
Transom installation opposite hinge side with link arm	750 mm	1400 mm
Door leaf installation hinge side with roller guide rail	850 mm	1250 mm / 1400 mm*

* = Not suitable for fire protection doors!

EMD, EMD-F, EMD-F-IS, EMD INVERS

Double leaf doors	Hinge clearance (min.)	Hinge clearance (max.)	Leaf width (min.) Active leaf / passive leaf	Leaf width (max.)
Transom installation hinge side / opposite hinge side with roller guide rail	1700 mm	2500 / 2800 mm*	850 mm	1250 / 1400 mm*
Transom installation opposite hinge side with link arm	1500 mm	2800 mm	750 mm	1400 mm

* = Not suitable for fire protection doors!

AREAS OF APPLICATION

**Note:**

Low-energy mode without protection should only be considered if the risk assessment for people in special need of protection has shown that the risk to these users is low. If there is a potential risk, then the hazardous area, such as the rotation range and the secondary closing edge, must be protected using additional safety measures.

SLIMDRIVE EMD

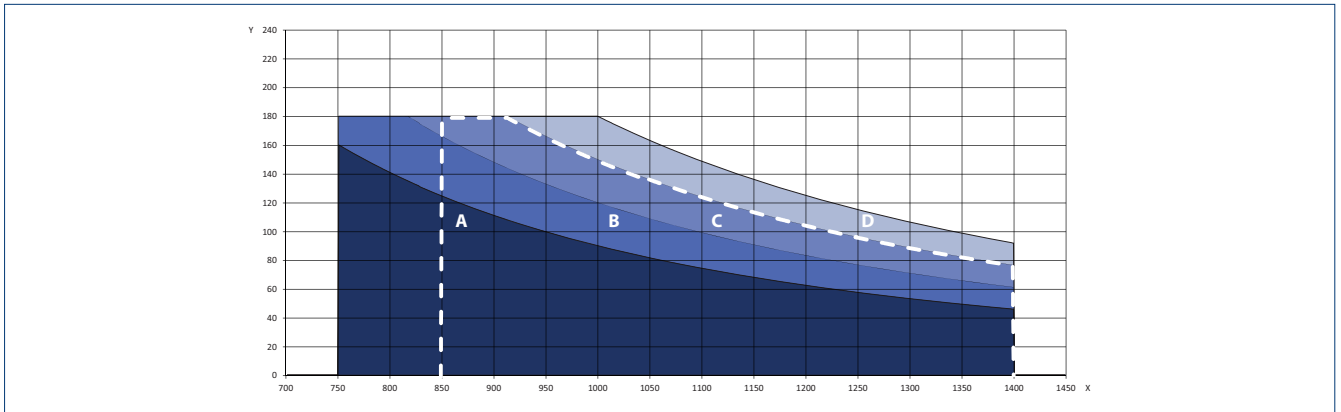

X = Door width (mm) | Y = Door weight (kg) | Dashed line: Area of application for installation with roller guide rail

SHORTEST PERMITTED OPENING TIMES IN AREAS A-D

Diagram area	Opening time	Closing time
TRANSOM INSTALLATION HINGE SIDE WITH ROLLER GUIDE RAIL		
A	3 s	4.5 s
B	4 s	5.5 s
C	5 s	6.5 s
D	not permissible	
TRANSOM INSTALLATION OPPOSITE HINGE SIDE WITH ROLLER GUIDE RAIL		
A	4 s	4.5 s
B	4.5 s	5.5 s
C	5 s	5.5 s
D	not permissible	
TRANSOM INSTALLATION OPPOSITE HINGE SIDE WITH LINK ARM		
A	3 s	4 s
B	3 s	4.5 s
C	4 s	5.5 s
D	5 s	6.5 s
DOOR LEAF INSTALLATION HINGE SIDE WITH ROLLER GUIDE RAIL		
A	4 s	4.5 s
B	4.5 s	5.5 s
C	4.5 s	5.5 s
D	not permissible	

SLIMDRIVE EMD-F AND SLIMDRIVE EMD INVERS

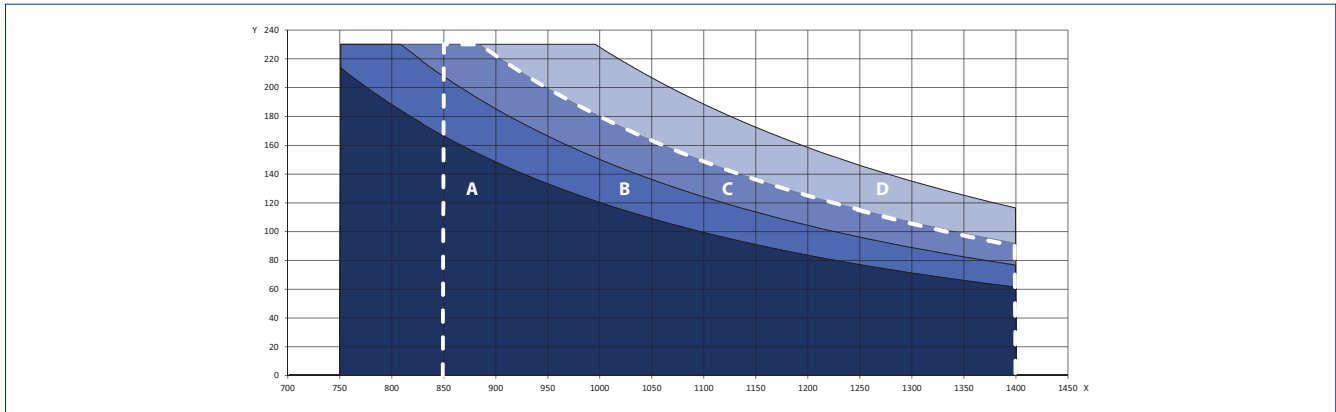

X = Door width (mm) | Y = Door weight (kg) | Dashed line: area of application for installation with roller guide rail

SHORTEST POSSIBLE OPENING TIMES IN AREAS A-D
(SET VALUES FOR ST 220 AND DPS)

Diagram area	Opening time	Closing time
TRANSOM INSTALLATION HINGE SIDE WITH ROLLER GUIDE RAIL		
A	3.5 s	4.5 s
B	4 s	5 s
C	4 s	5.5 s
D	not permissible	
TRANSOM INSTALLATION OPPOSITE HINGE SIDE WITH ROLLER GUIDE RAIL		
A	5 s	4.5 s
B	6 s	5 s
C	6.5 s	5.5 s
D	not permissible	
TRANSOM INSTALLATION OPPOSITE HINGE SIDE WITH LINK ARM		
A	3.5 s	4.5 s
B	4 s	5 s
C	4.5 s	5.5 s
D	5 s	6 s
DOOR LEAF INSTALLATION HINGE SIDE WITH ROLLER GUIDE RAIL		
A	3.5 s	4.5 s
B	4 s	5.5 s
C	4.5 s	6 s
D	not permissible	

→ **Note:** We recommend the use of link arms for exterior doors. Load due to wind pressure as well as underpressure or excess pressure must also be taken into account. Dimensions marked by an asterisk (*) are valid for direct attachment. A door stopper is necessary.

PRODUCT SCALE DRAWING

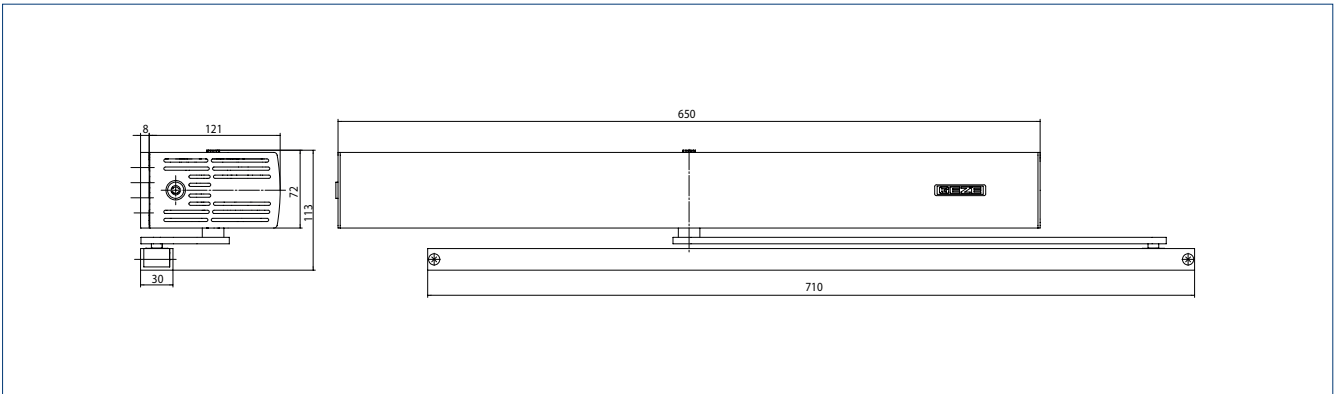

Slimdrive EMD

TRANSOM INSTALLATION WITH ROLLER GUIDE RAIL ON THE HINGE SIDE, SINGLE LEAF

Drawing no. 70106-ep01
 Door overlap (max.) 30 mm
 Door opening angle (max.) 105°

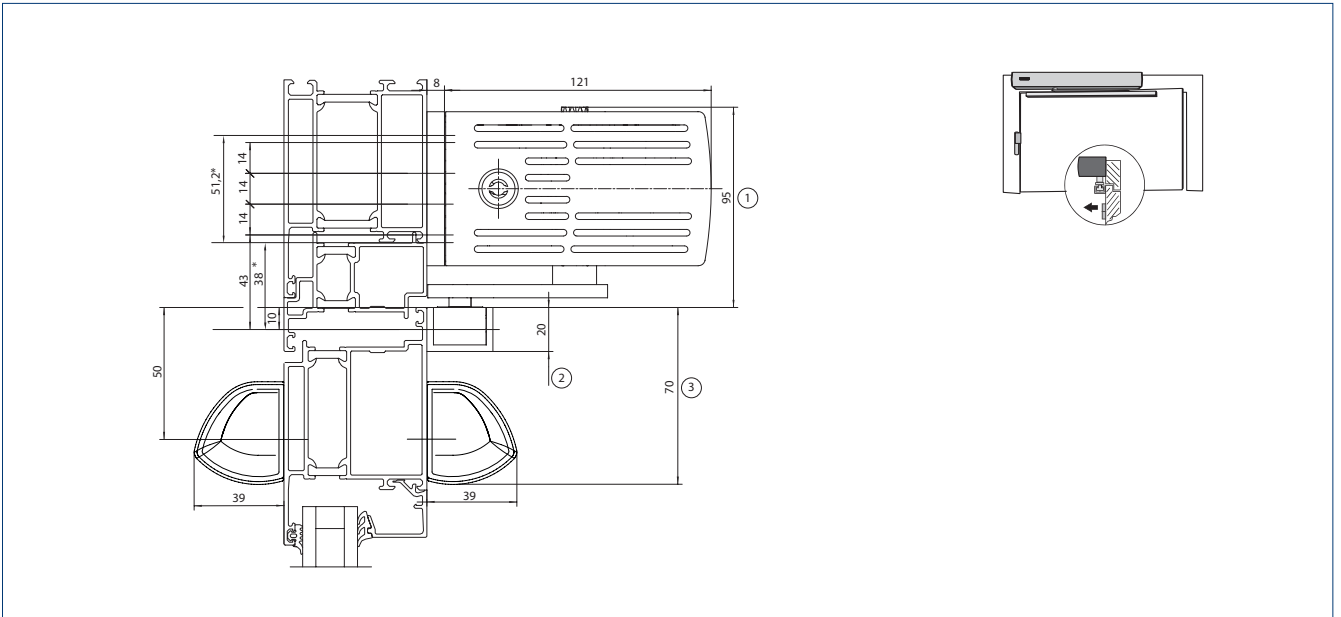

* = Direct installation | 1 = Space needed for EMD-F/EMD Invers | 2 = Space needed for roller guide rail | 3 = Space needed for sensor strips

INSTALLATION WITH MOUNTING PLATE (A) AND DIRECT INSTALLATION (B)

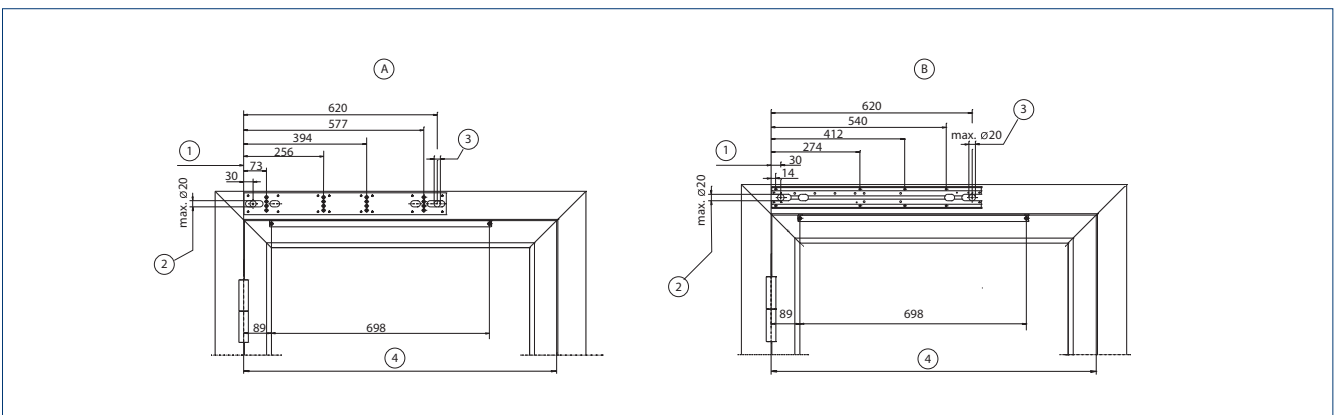

A = Installation with mounting plate | B = Direct installation | 1 = Dimensional reference centre of hinge | 2 = Concealed line-feed for sensors, electric strike, programme switch and lock switch contact | 3 = Concealed line-feed 230 V / 50 Hz | 4 = Door leaf width

TRANSOM INSTALLATION WITH LINK ARM ON THE OPPOSITE HINGE SIDE, SINGLE LEAF

Drawing no. 70106-ep03

Reveal depth (max.) 0-100 mm, 100-200 mm, 200-300 mm, approved reveal depth on fire protection doors max. 250 mm

Door opening angle (max.) 110°

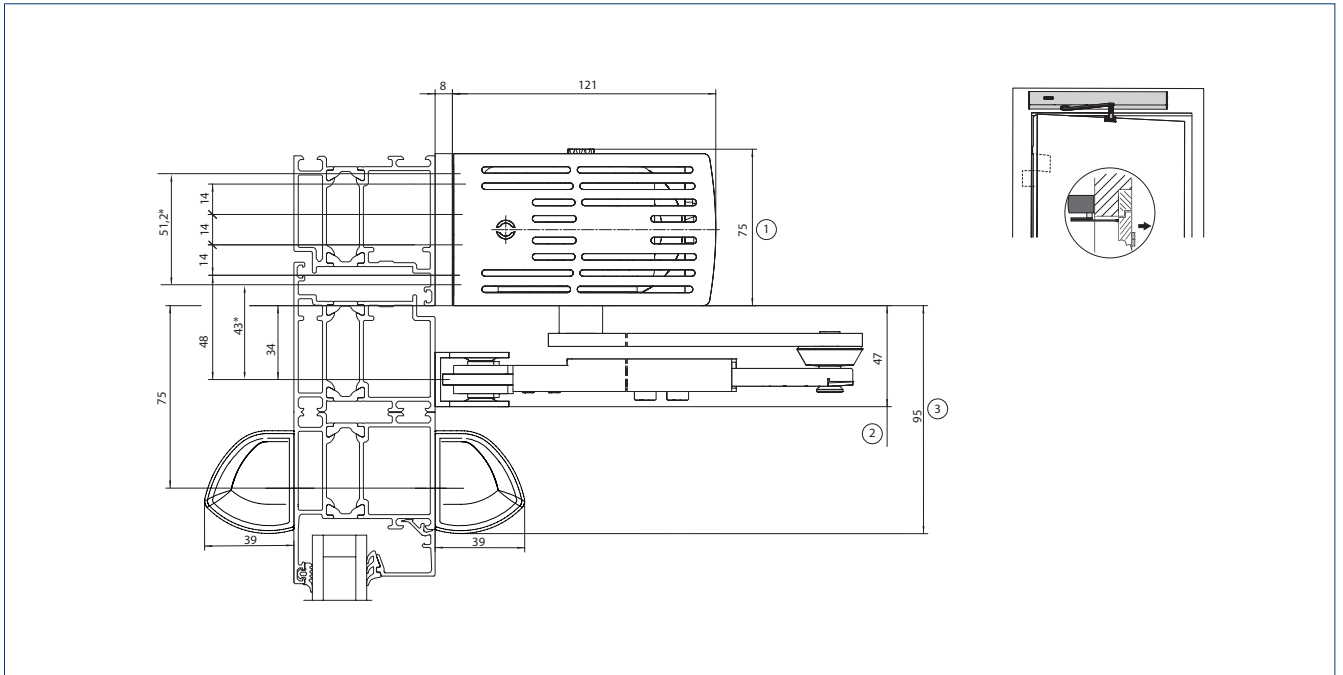

* = Direct installation | 1 = Space needed for EMD-F/EMD Invers | 2 = Space needed for link arm | 3 = Space needed for sensor strips

INSTALLATION WITH MOUNTING PLATE (A) AND DIRECT INSTALLATION (B)

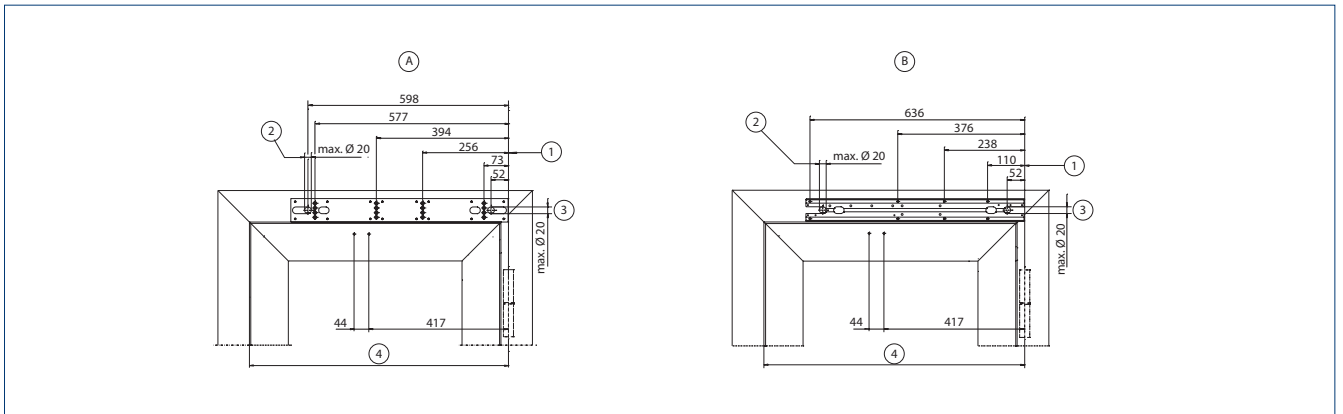

A = Installation with mounting plate | B = Direct installation | 1 = Dimensional reference centre of hinge | 2 = Concealed line-feed for sensors, electric strike, programme switch and lock switch contact | 3 = Concealed line-feed 230 V / 50 Hz | 4 = Door leaf width

TRANSOM INSTALLATION WITH ROLLER GUIDE RAIL ON THE HINGE SIDE, DOUBLE LEAF

Drawing no. 70106-ep21

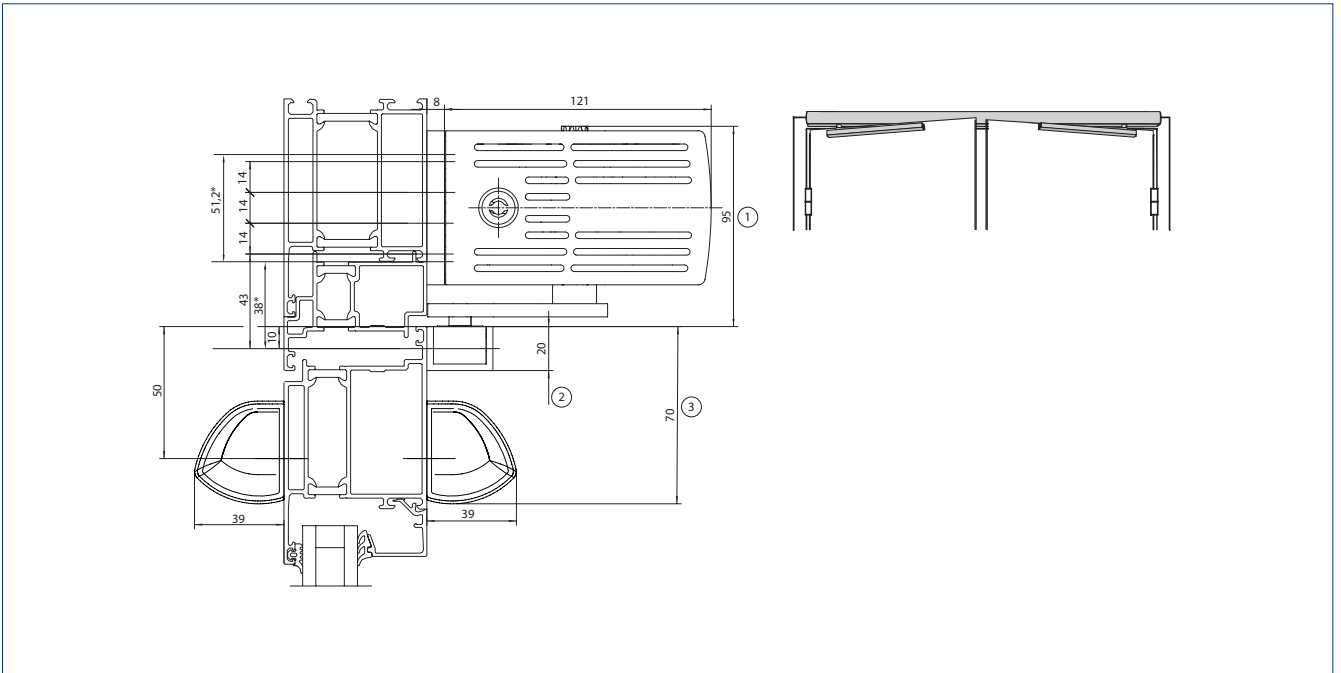

* = Direct installation | 1 = Space needed for EMD-F/EMD Invers | 2 = Space needed for roller guide rail | 3 = Space needed for sensor strips

INSTALLATION WITH MOUNTING PLATE (A) AND DIRECT INSTALLATION (B)

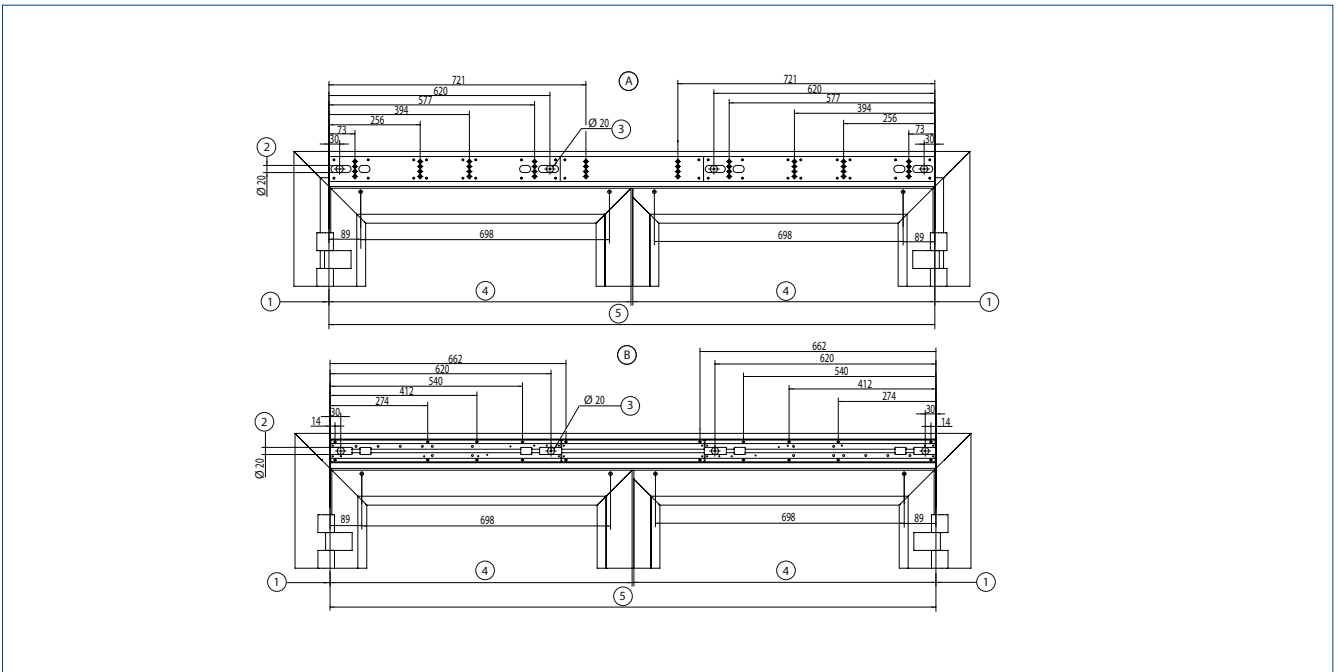

A = Installation with mounting plate | B = Direct installation | 1 = Dimensional reference centre of hinge | 2 = Concealed line-feed for sensors, electric strike, programme switch and lock switch contact | 3 = Concealed line-feed 230 V / 50 Hz | 4 = Door leaf width | 5 = Hinge clearance

TRANSOM INSTALLATION WITH ROLLER GUIDE RAIL ON THE OPPOSITE HINGE SIDE, DOUBLE LEAF

Drawing no. 70106-ep22

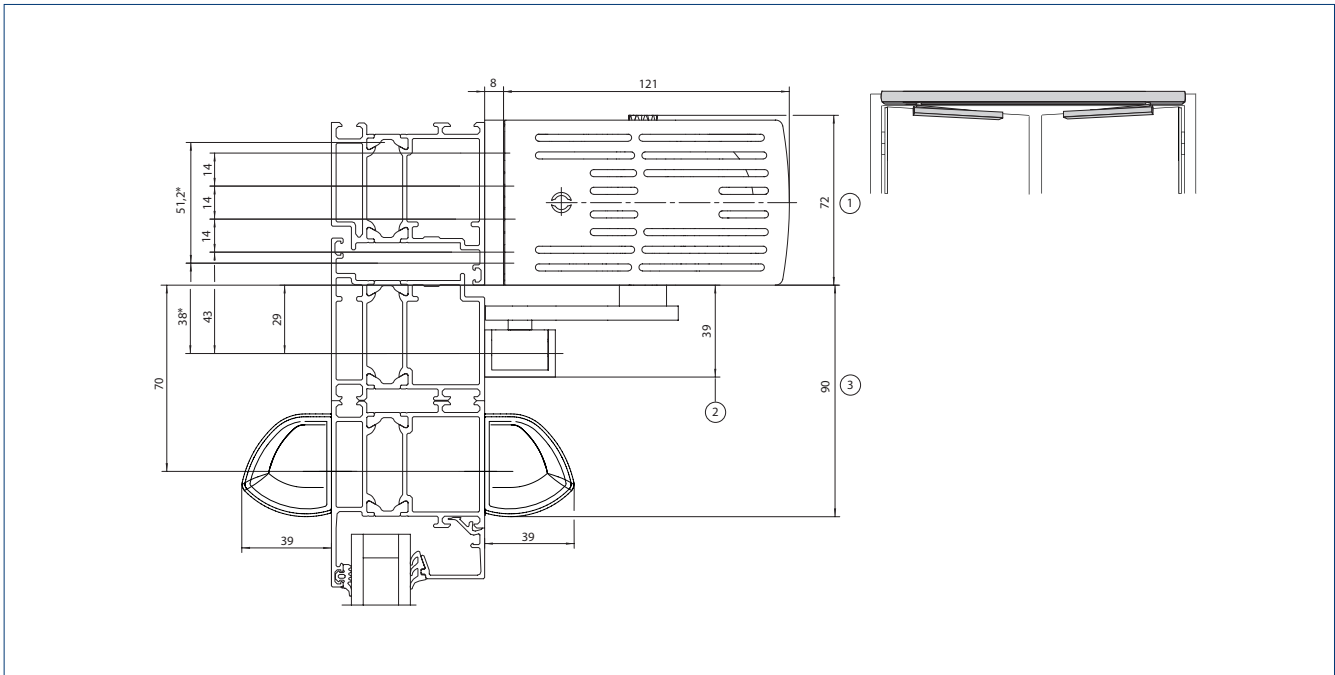

* = Direct installation | 1 = Space needed for EMD-F/EMD Invers | 2 = Space needed for roller guide rail | 3 = Space needed for sensor strips

INSTALLATION WITH MOUNTING PLATE (A) AND DIRECT INSTALLATION (B)

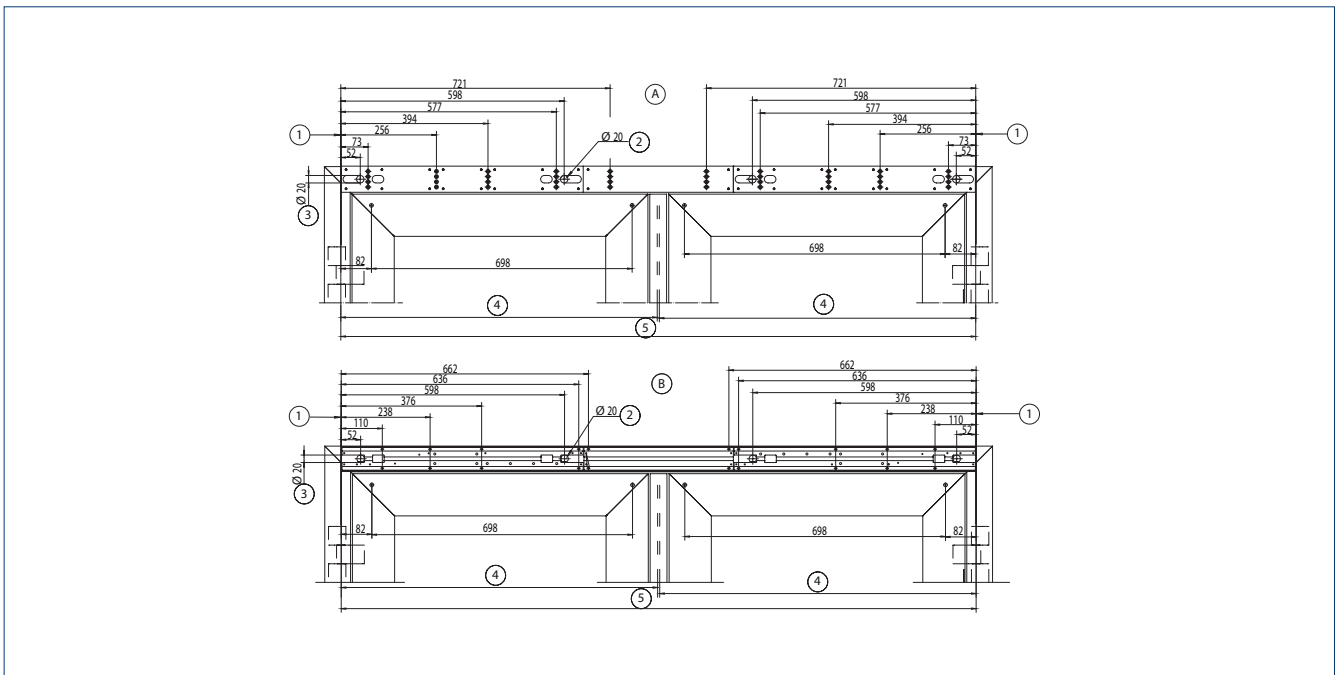

A = Installation with mounting plate | B = Direct installation | 1 = Dimensional reference centre of hinge | 2 = Concealed line-feed for sensors, electric strike, programme switch and lock switch contact | 3 = Concealed line-feed 230 V / 50 Hz | 4 = Door leaf width | 5 = Hinge clearance

TRANSOM INSTALLATION WITH LINK ARM ON THE OPPOSITE HINGE SIDE, DOUBLE LEAF

Drawing no. 70106-ep23

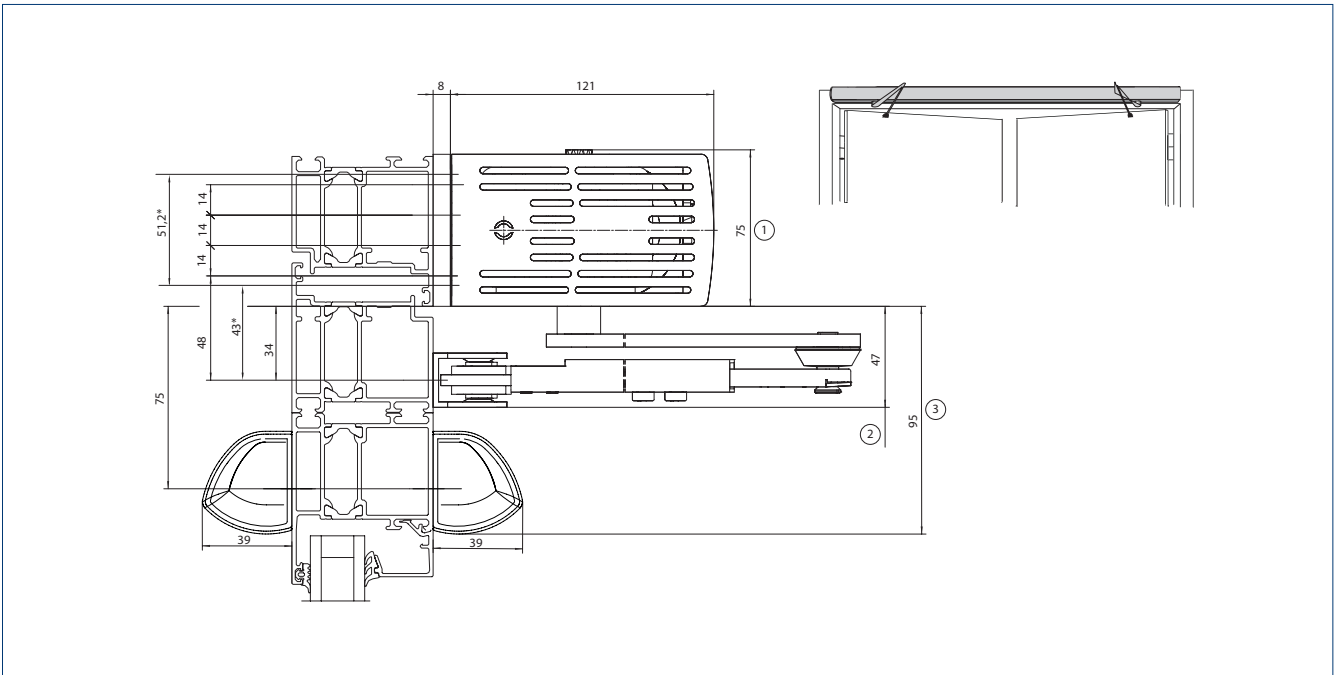

* = Direct installation | 1 = Space needed for EMD-F/EMD Invers | 2 = Space needed for link arm | 3 = Space needed for sensor strips

INSTALLATION WITH MOUNTING PLATE (A) AND DIRECT INSTALLATION (B)

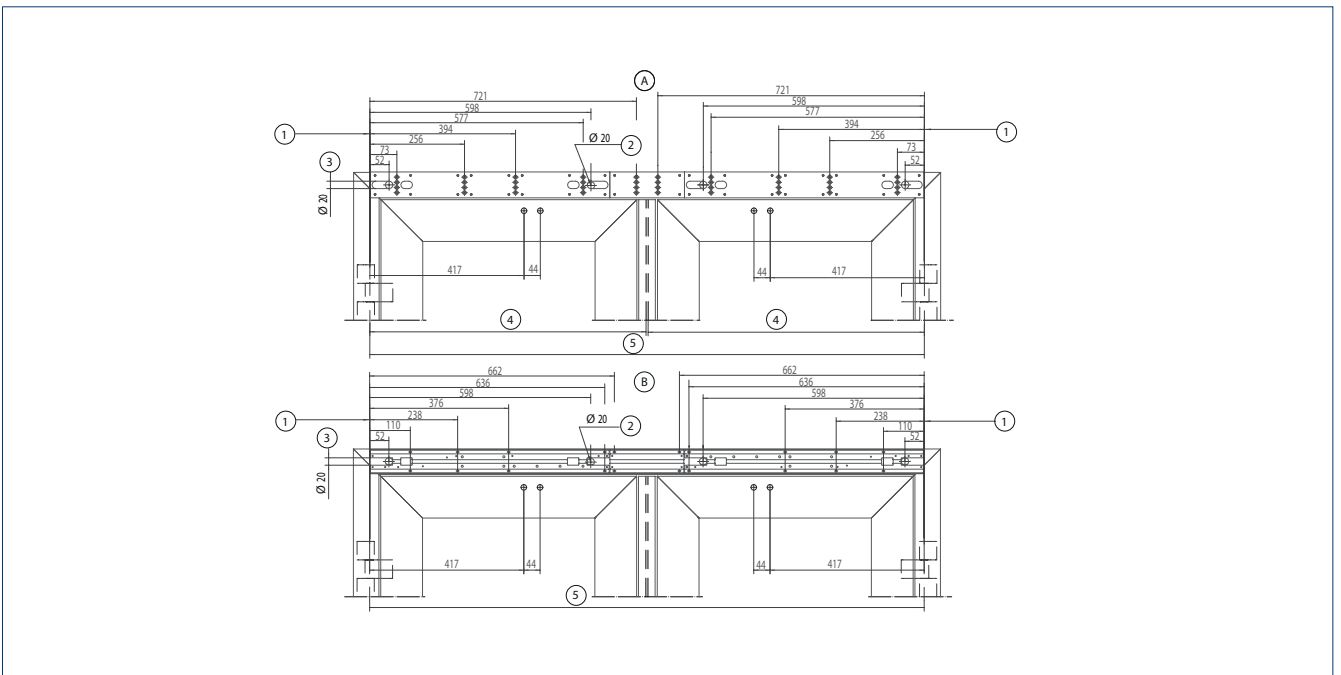

A = Installation with mounting plate | B = Direct installation | 1 = Dimensional reference centre of hinge | 2 = Concealed line-feed for sensors, electric strike, programme switch and lock switch contact | 3 = Concealed line-feed 230 V / 50 Hz | 4 = Door leaf width | 5 = Hinge clearance

LEGEND FOR THE CABLE PLANS

CABLES

- 1 = NYM-J 3 × 1.5 mm²
- 2 = J-Y(ST)Y 1 × 2 × 0.6 LG
- 3 = J-Y(ST)Y 2 × 2 × 0.6 LG
- 4 = J-Y(ST)Y 4 × 2 × 0.6 LG
- 5 = LiYY 2 × 0.25 mm²
- 6 = LiYY 4 × 0.25 mm²
- 7 = Scope of supply sensor strip or LiYY 5 × 0.25 mm²
- 8 = Route empty pipe with pull-wire inner diameter 10 mm

ABBREVIATIONS

HS	Main switch	KA	Contact sensor outside
NOT	Emergency shut off switch	TOE	Electric strike
UT	CLOSE DOOR manual trigger switch (only for F variant)	RM	Bolt message
KB	Mechanical contact	RS	Smoke switch (only with F variant)
PS	Programme switch	RSZ	Smoke switch control unit (only with F variant)
ST	Emergency stop button	TS	Door closer
KI	Contact sensor inside	MK	Magnetic contact



Notes:



- Cable plans can also be prepared for specific projects after receipt of order
- Version of standard cable plans in accordance with GEZE specifications
- Wiring in accordance with VDE 0100
- Allow the cable for the drive to project at least 1500 mm out of the wall

1 Door transmission cable (included in the scope of supply for sensor strip), cable guide through a hole in the door leaf is not permitted for fire protection doors. | 2 Cable exit for drive unit, see installation drawings for Slimdrive EMD/EMD-F 70106-ep01 to -ep04 | 3 Cable included in the scope of supply for the sensor 4) Install in the direct vicinity of the door | 5 Mains connection box W×H×D min. 65 × 65 × 57 with PG-11 duct, on site | 6 Low-voltage connection box W×H×D min. 94 × 65 × 57 with PG-11 duct, on site | 7) E.g. door transmission cable, 8-wire, mat. no. 066922 | 8 Branch box, on site

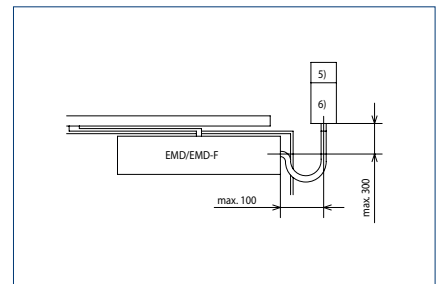
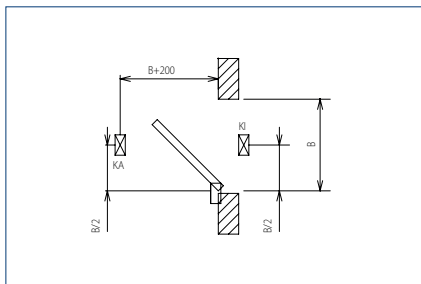
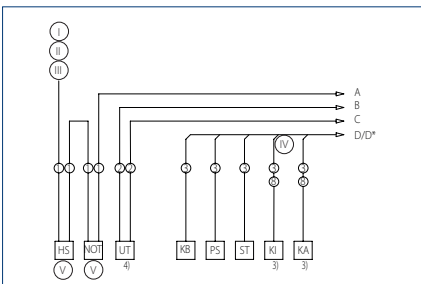

I = Power supply circuit 230 V / 50 Hz | II = Safety fuse 10 A | III = Connection value 230 W, 1 A single, double leaf with manual passive leaf; connection value 460 W, 1 A for double leaf | IV = And / Or | V = Option

SINGLE LEAF

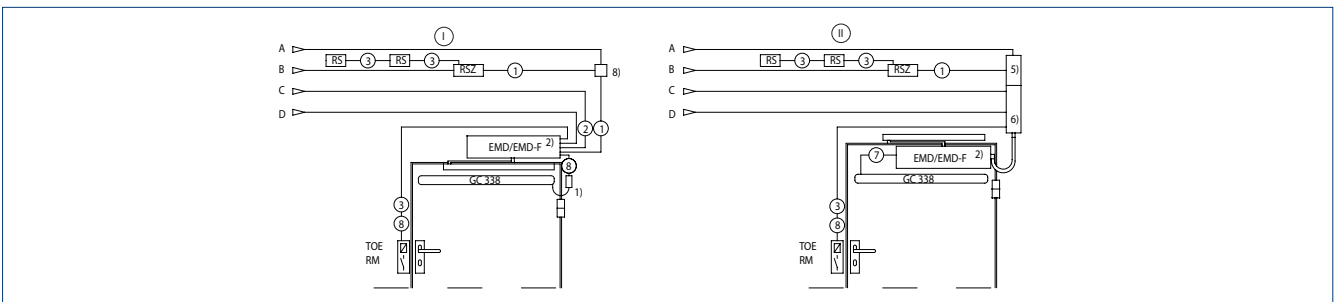

DOUBLE LEAF

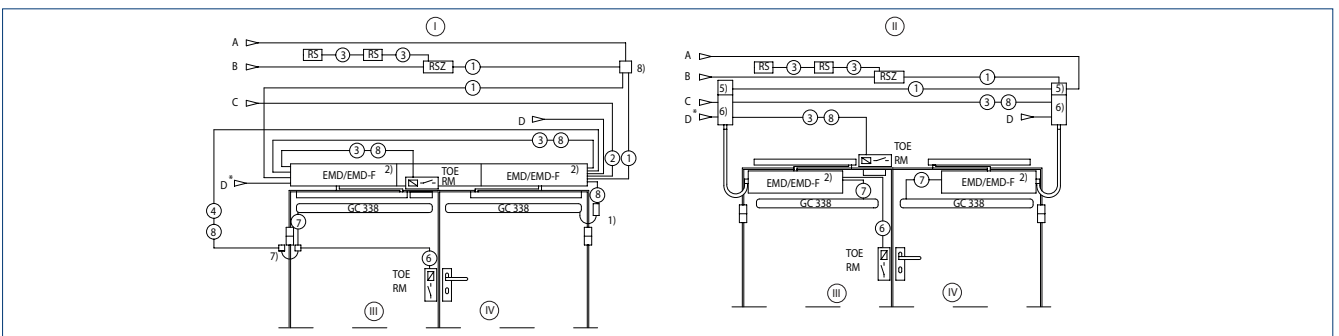

I = Transom installation | II = Door leaf installation | III = Passive leaf | IV = Active leaf

Powerturn



Electromechanical swing door drive
for single and double leaf doors up to 600 kg



AREAS OF APPLICATION

- Single and double leaf right and left single-action doors
- Single-action doors up to 1600 mm leaf width or 600 kg weight
- Minimum door leaf width is 800 mm
- Interior and exterior doors with high access frequency
- Door leaf installation and transom installation

PRODUCT FEATURES

- Smart swing function for easy manual door opening
- Closing force of EN4-7 with variable adjustment
- Opening and closing speed can be individually adjusted
- Mechanical latching action when operated without current, and electrical automatic unit latching action in regular operation, which accelerates the door shortly before the closed position
- Low-energy function opens and closes the door with reduced speed, fulfilling the highest safety demands
- Servo function for motorized support when manually opening the door
- Obstacle detection detects an obstacle through contact and stops the opening or closing process
- Automatic reversing detects an obstacle and returns to the opening position
- Push & Go function triggers the automatic drive components following light manual pressure on the door leaf
- Drive can be used with roller guide rail or link arm
- Optional radio board for wireless activation by radio transmitter
- Freely configurable inputs and outputs for different functions
- Can be networked via CAN bus and integrated into building technology management systems
- Hold-open function can be activated by manually pulling the door leaf closed
- Reset of the hold-open system by manually opening the door leaf to an opening angle of 80° or changing the mode of operation

TECHNICAL DATA POWERTURN SINGLE LEAF

	Powerturn	Powerturn F	Powerturn F/R
PRODUCT FEATURES			
Height	70 mm		
Width	720 mm	920 mm	
Depth	130 mm		
Leaf weight (max.) single leaf	600 kg		
Leaf width (min.-max.)*	800 – 1600 mm		857 mm – 1600 mm
Reveal depth (max.)*	560 mm	300 mm	
Drive type	Electromechanical		
Door opening angle (max.)*	136°		
Spring pre-load**	EN4 – EN7		
DIN left	●	●	●
DIN right	●	●	●
Transom installation opposite hinge side with link arm	●	●	●
Transom installation opposite hinge side with Roller guide rail	●	●	●
Transom installation hinge side with roller guide rail	●	●	●
Door leaf installation opposite hinge side with roller guide rail	●	●	-
Door leaf installation hinge side with roller guide rail	●	●	-
Door leaf installation hinge side with link arm	●	●	-
Mechanical latching action	●	●	●
Electrical latching action	●	●	●
Disconnection from mains	Main switch in the drive		
Activation delay (max.)	10 s		
Operating voltage	230 V		
Frequency of supply voltage	50 Hz		
Capacity rating	200 W		
Power supply for external consumers (24 V DC)	1200 mA		
Temperature range****	-15 – 50° C		
IP rating	IP30		
Modes of operation	Automatic, night mode, hold open, exit only, off		
Type of function	Fully automatic		
Automatic function	●	●	●
Low-energy function	●	●	●
Smart swing function	●	●	●
Function keys	●	●	●
Vestibule function	●	●	●
Obstacle detection	●	●	●
Automatic reversing	●	●	●
Push & Go	adjustable		
Operation	Programme switch integrated on the drive unit, MPS, DPS		
Parameter setting	myGEZE Connects, ST 220 service terminal, DPS		
Approvals	DIN 18650, EN 16005, DIN 18263-4 only for Powerturn F and Powerturn F/R		
Suitable for fire protection doors	-	●	●
Integrated smoke switch (R variant)	-	-	●
Release and reset of the hold-open system	-	by push button, by moving the door leaf	

● = yes | * = Depending on type of installation | ** = See torque overview table | *** = The drive is designed exclusively for use in dry rooms

→ **Note:** The maximum possible leaf weight in relation to leaf width can be found in the chapter on areas of application (charts).

TECHNICAL DATA POWERTURN DOUBLE LEAF

	IS	F-IS	F/R-IS	IS/TS	F-IS/TS	F/R-IS/TS
PRODUCT FEATURES						
Height	70 mm					
Width	depending on the hinge clearance					
Depth	130 mm					
Leaf weight (max.) single leaf	600 kg					
Hinge clearance (min.-max.) double leaf link arm	1600 – 3200 mm		1720 – 3200 mm	1270 – 3200 mm		
Hinge clearance (min.-max.) double leaf roller guide rail	1600 – 2800 mm		1720 – 2800 mm	1380–3000 mm	1380 – 2800 mm (F/R variant)	
Leaf width (min.-max.)*	800 – 1600 mm		800 ⁵ –1600 mm	470 – 1600 mm		
Reveal depth (max.)*	300 mm			160 mm		
Drive type	Electromechanical					
Door opening angle (max.)*	136°					
Spring pre-load**	EN4 – EN7			EN1 – EN7		
DIN left	●	●	●	●	●	●
DIN right	●	●	●	●	●	●
Transom installation opposite hinge side with link arm	●	●	●	●	●	●
Transom installation opposite hinge side with roller guide rail	●	●	●	-	-	-
Transom installation hinge side with roller guide rail	●	●	●	●	●	●
Door leaf installation opposite hinge side with roller guide rail	-	-	-	-	-	-
Door leaf installation hinge side with roller guide rail	-	-	-	-	-	-
Door leaf installation hinge side with link arm	-	-	-	-	-	-
Mechanical latching action	●	●	●	●	●	●
Electrical latching action	●	●	●	●	●	●
Electrical closing sequence control	●	●	●	-	-	-
Mechanical closing sequence control***	●	●	●	●	●	●
Disconnection from mains	Main switch in the drive					
Activation delay (max.)	10 s					
Operating voltage	230 V					
Frequency of supply voltage	50 Hz					
Capacity rating	200 W					
Power supply for external consumers (24 V DC)	1200 mA					
Temperature range****	-15 – 50° C					
IP rating	IP30					
Modes of operation	Automatic, night mode, hold open, exit only, off					
Type of function	Fully automatic					
Automatic function	●	●	●	●	●	●
Low-energy function	●	●	●	●	●	●
Smart swing function	●	●	●	●	●	●
Function keys	●	●	●	●	●	●
Vestibule function	●	●	●	●	●	●
Obstacle detection	●	●	●	●	●	●
Automatic reversing	●	●	●	●	●	●
Push & Go	adjustable					
Operation	Programme switch integrated on the drive unit, MPS, DPS					
Parameter setting	myGEZE Connects, ST 220 service terminal, DPS					
Approvals	DIN 18650, EN 16005, DIN 18263-4 only for F-IS, F/R-IS, F-IS/TS and F/R-IS/TS, Closing sequence controller tested acc. to EN 1158					
Suitable for fire protection doors	-	●	●	-	●	●
Integrated smoke switch (R variant)	-	-	●	-	-	●

● = yes | * = Depending on type of installation | ** = See torque overview table | *** = Types of installation: Transom installation types with link arm/roller guide rail | **** = The drive is designed exclusively for use in dry rooms | 5 = 857 mm on the active leaf

→ **Note:** The maximum possible leaf weight in relation to leaf width can be found in the chapter on areas of application (charts).

TECHNICAL DATA FOR USE OF THE IS/TS VARIANT
POWERTURN IS/TS WITH TS 5000 L DOOR CLOSER

Element	Active leaf		Passive leaf	System	
Drive/door closer	Powerturn	Powerturn F Powerturn F/R	TS 5000 L	Powerturn IS/TS	Powerturn F-IS/TS Powerturn F/R-IS/TS
Lever type	Roller guide rail		Guide rail		
Min. – max. leaf width	800 – 1,600 mm	800 – 1,400 mm	580 – 1,400 mm		
Min. – max. hinge clearance				1,380 – 3,000 mm	1,380 – 2,800 mm 1,500 – 2,800 mm (F/R variant)
Reveal			0 mm		
EN closing force	EN 4-6		EN 2-6		EN 3-6

POWERTURN IS/TS WITH DOOR CLOSER TS 4000

Element	Active leaf		Passive leaf	System	
Drive/door closer	Powerturn	Powerturn F Powerturn F/R	TS 4000 EN 1-6 or EN 5-7	Powerturn IS/TS	Powerturn F-IS/TS Powerturn F/R-IS/TS
Lever type	Link arm		Link arm		
Min. – max. leaf width	800 – 1,600 mm		470 – 1600 mm		
Min. – max. hinge clearance				1,270 – 3,200 mm 1,500 – 3,200 (F/R variant)	
Reveal			0 – 160 mm		
EN closing force	EN 6-7		EN 1-7*		EN 3-7

* Standard version with TS 4000 EN 1-6, on request via Customer Solutions there is the option for the use of TS 4000 EN 5-7

AREAS OF APPLICATION

POWERTURN WITH OPENING TIMES UP TO 90° DOOR OPENING ANGLE

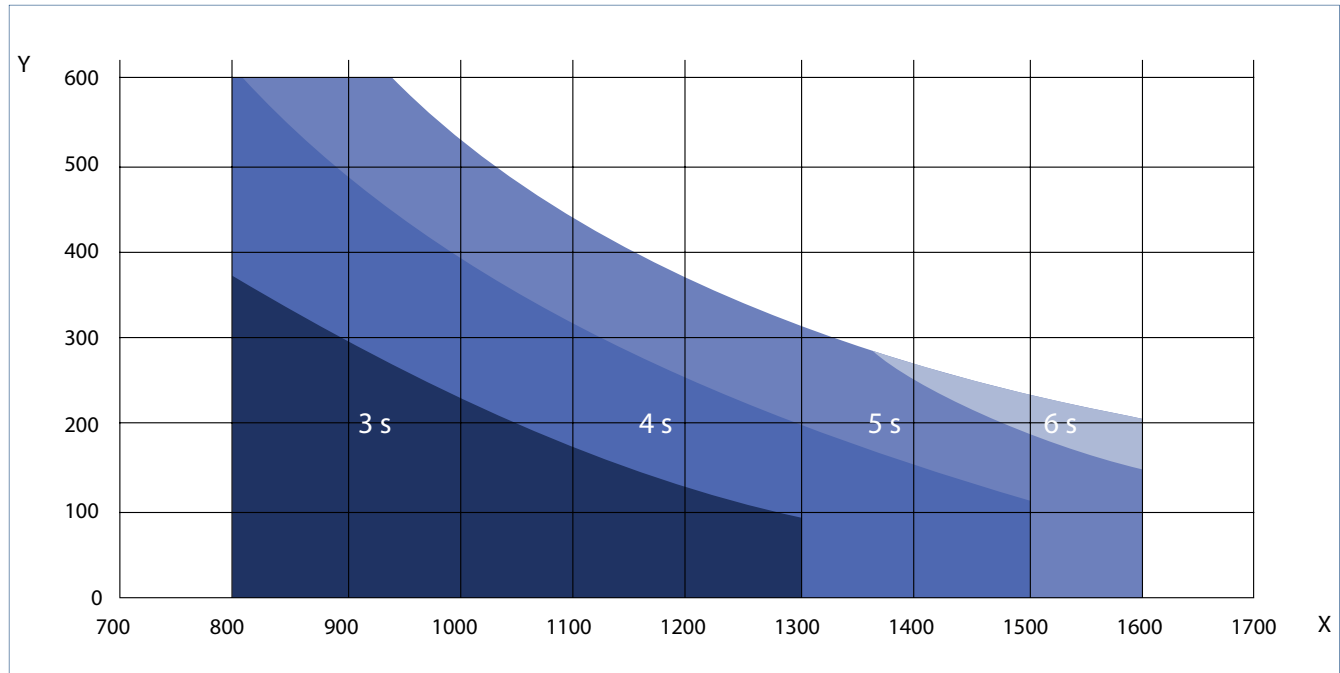

X = Door width (mm) | Y = Door weight (kg)

OPENING TIMES POWERTURN

The following minimum opening times must be complied with in order to comply with safety requirements in low-energy mode. All values in seconds.

Door weight (kg)

	60	90	120	150	180	210	240	270	300	330	370	400	430	460	490	520	550	580	600
800	4	4	5	5	6	6	7	7	7	8	8	8	9	9	9	10	10	10	10
900	4	5	5	6	7	7	7	8	8	9	9	9	10	10	11	11	11	11	11
1000	4	5	6	7	7	8	8	9	9	10	10	10	11	11	12	12			
1100	5	6	6	7	8	8	9	9	10	10	11	11	12						
1200	5	6	7	8	8	8	10	10	11	11	12								
1300	6	7	8	8	9	10	11	11	12	12									
1400	6	7	8	9	10	11	11	12											
1500	6	8	9	10	11	11													
1600	7	8	9	10	11	12													



Note:



Low-energy mode without protection should only be considered if the risk assessment for people in special need of protection has shown that the risk to these users is low. If there is a potential risk, then the hazardous area, such as the rotation range and the secondary closing edge, must be protected using additional safety measures.

Illustration of the minimum opening times to be set depending on the door weight and door leaf width for a door opening from 0° to 80° or for a closing movement from 90° to 10° door opening angle.

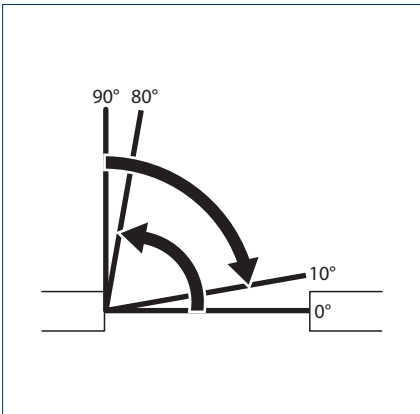

OVERVIEW OF TORQUES – POWERTURN

		K-BS rail		K-BGS rail		T-BS rail		T-BGS rail		K-BGS link arm		T-BS link arm	
		Min	Max	Min	Max	Min	Max	Min	Max	Min	Max	Min	Max
EN 1154	EN class	4	6	4	6	4	6	5	6	6	7	6	7
Closing torques	Nm (door)	0	60	0	60	0	60	0	60	0	100	0	100
OPN_TORQ MAX automatic	Nm (door)	135		121		143		127		180*		180*	
Opening torque manual (Off mode of operation)	Nm (door)	10		9		11		10		19		21	

* = Restricted according to DIN 18263-4 | K = Transom installation | T = Door leaf installation | BS = Hinge side | BGS = Opposite hinge side

→ **Note:** The doors must be fitted with suitable hinges for automatic operation. A door stopper is necessary.

INSTALLATION

The Powerturn allows the following types of installation, each in DIN left and DIN right:

Type of installation

–Transom installation hinge side rail

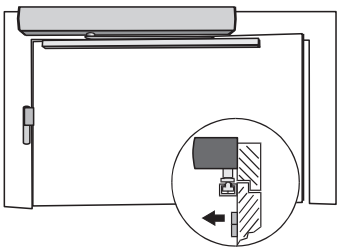

Dimension	Powerturn	Powerturn F
Reveal depth LT [mm]	0–100 ⁵ (60–200) ^{1, 5}	0–100
Door overlap Ü [mm]	0–30	
Max. door opening angle TÖW [°]	approx. 102–133 ²	
Standard guide rail L = [mm]	687	
Lever L = [mm]	330	
Distance centre door hinge–drive axis [mm]	190	
EN class	4–6	

–Transom installation opposite hinge side rail

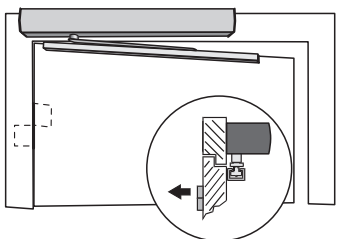

Reveal depth + door leaf thickness [mm]	max. 100	
Max. door opening angle TÖW [°]	approx. 108 ³	
Standard guide rail L = [mm]	687	
Lever L = [mm]	450	
Distance centre door hinge–drive axis [mm]	190	
EN class	4–6	

Type of installation

Dimension

Powerturn

Powerturn F

–Door installation hinge side rail

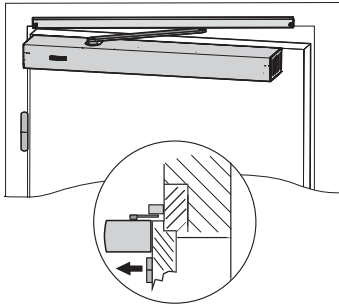

Reveal depth LT [mm]		0-50
Door overlap Ü [mm]		0-30
Max. door opening angle TÖW [°]		approx. 126 ³
Standard guide rail	L = [mm]	734
Lever	L = [mm]	330
Distance centre door hinge-drive axis [mm]		220
EN class		4-6

–Door installation opposite hinge side rail

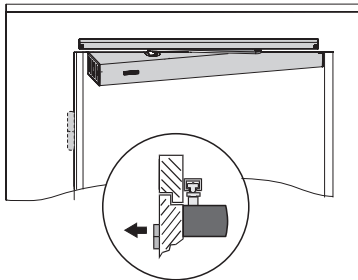

Reveal depth LT [mm]		0
Max. door opening angle TÖW [°]		approx. 104
Standard guide rail	L = [mm]	734
Lever	L = [mm]	450
Distance centre door hinge-drive axis [mm]		220
EN class		5-6
Max. door leaf thickness [mm]		100

Door installation hinge side link arm

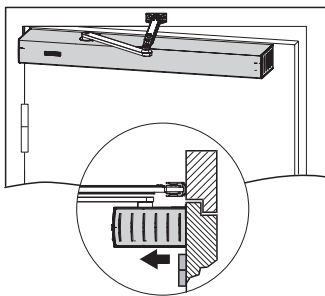

Reveal depth LT [mm]		0
Door overlap Ü [mm]	0-30	0
Distance centre door hinge-drive axis [mm]		220
Max. door opening angle TÖW [°]		approx. 115
EN class		6-7

Transom installation opposite hinge side link arm

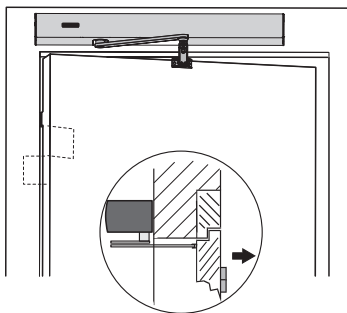

Standard reveal depth LT [mm]	up to 510	up to 300
Reveal depths LT with link arm adapter for sensor link arm [mm]	up to 560	up to 300
Max. door leaf thickness [mm]		150
Max. door opening angle TÖW [°]		approx. 110–135 ^{2,3,4}
Distance centre door hinge-drive axis [mm]		190
EN class		6-7

1 = With lever (450 mm) | 2 = Calculation max. door opening angle, see diagrams below | 3 = Door opening angle through collision lever/drive with door/frame | 4 = Diagram of transom installation–opposite hinge side–link arm/reveal–max. door opening angle, see below | 5 = Diagram of transom installation–hinge side–rail/reveal–max. door opening angle

REVEAL / MAX. DOOR OPENING ANGLE

TRANSOM INSTALLATION OPPOSITE HINGE SIDE LINK ARM

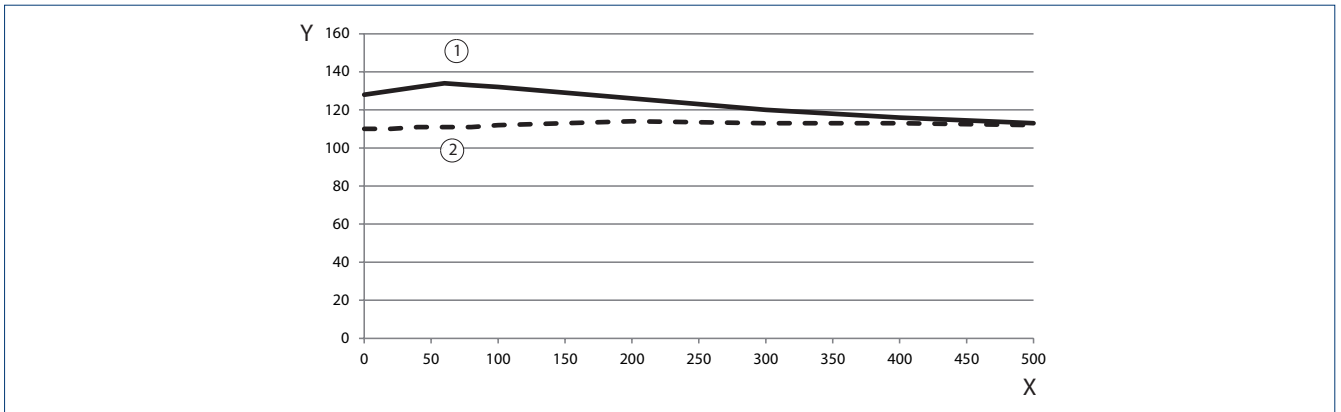

X = Reveal depth (mm) | Y = Max. door opening angle (°) | 1 = Door opening angle | 2 = Door opening angle with sensor link arm

TRANSOM INSTALLATION HINGE SIDE ROLLER GUIDE RAIL

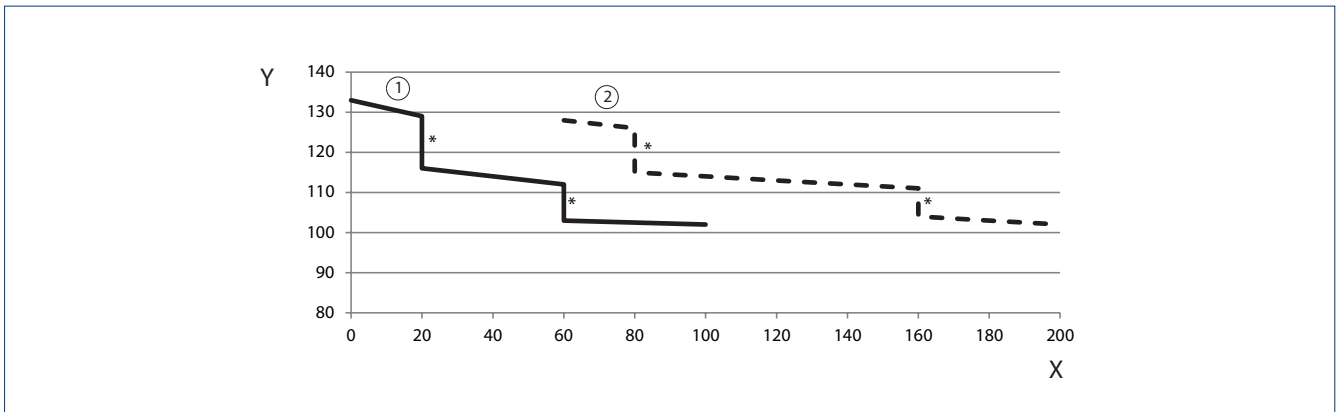

* = Preload | X = Reveal depth (mm) | Y = Max. door opening angle (°) | 1 = Lever 330 mm | 2 = Lever 450 mm

TRANSOM INSTALLATION WITH ROLLER GUIDE RAIL ON THE HINGE SIDE, SINGLE AND DOUBLE LEAF

Drawing no. 70109-ep01

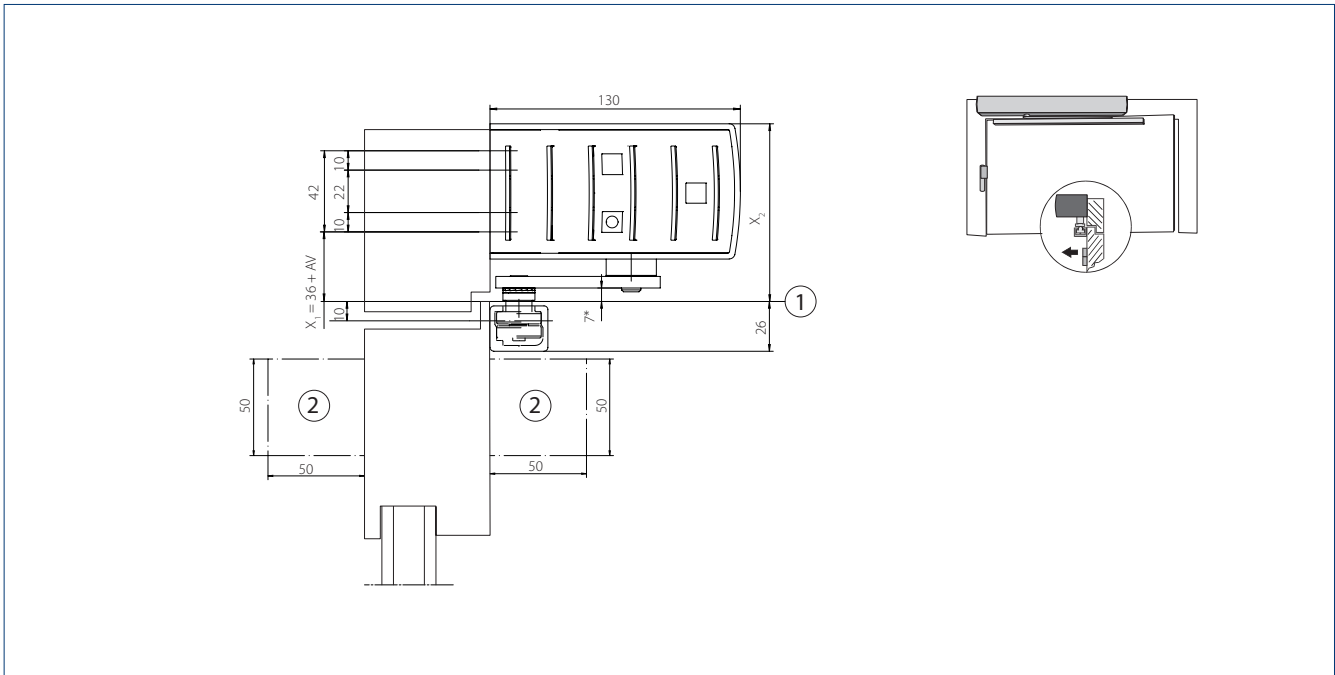

* = Important function dimension | AV = Spindle extension | 1 = Base top edge of door | 2 = Space needed for sensor strip

FITTING DIMENSION MOUNTING PLATE

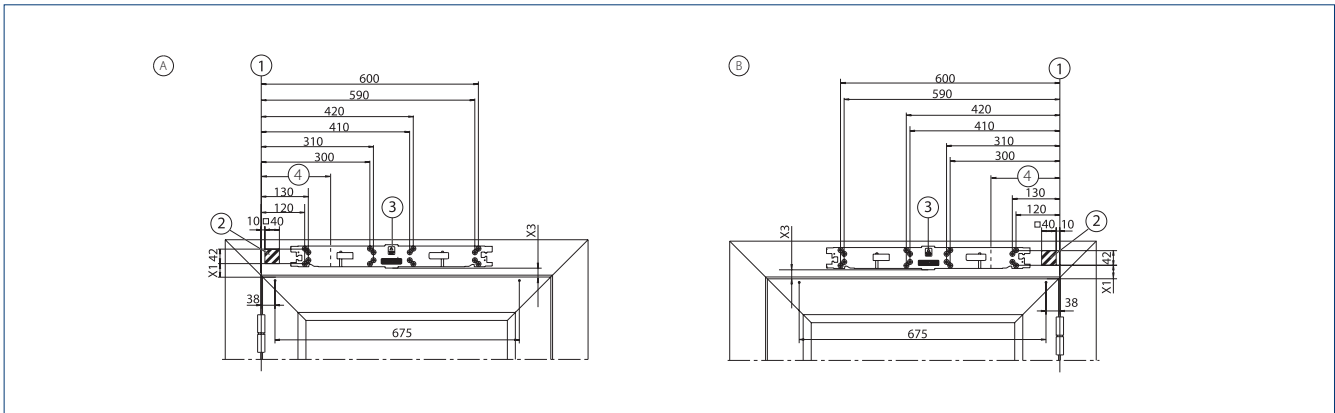

A = DIN left | B = DIN right | 1 = Dimensional reference centre of hinge / top edge of door | 2 = Concealed line-feed possible in the hatched area, e.g. Ø 20 mm for network connection or low-voltage connection | 3 = Orientation arrow for clear positioning of the mounting plate | 4 = Distance centre door hinge-drive axis

DOUBLE LEAF INSTALLATION WITH INTERMEDIATE COVER WITH DIVIDED OR CONTINUOUS COVER

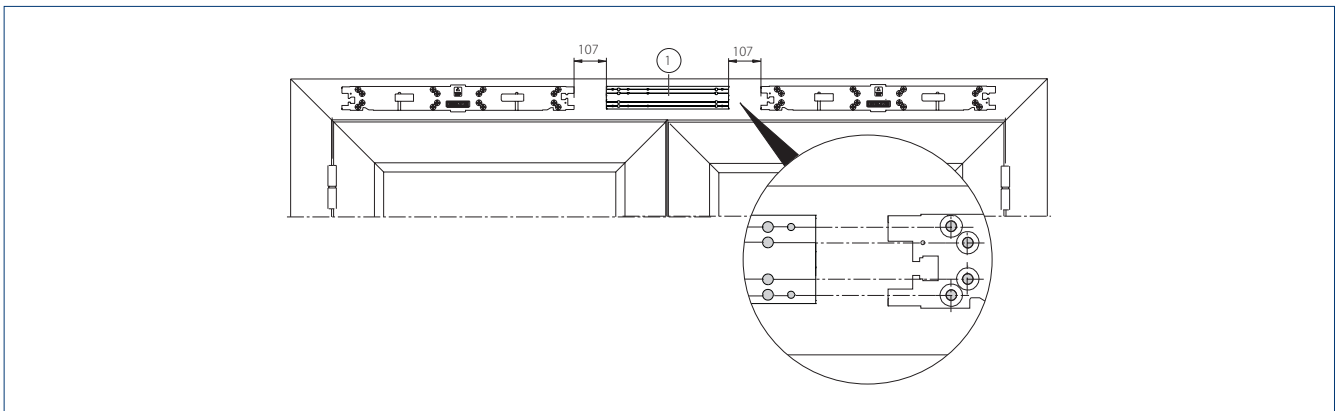

1 = Base plate

TRANSOM INSTALLATION WITH ROLLER GUIDE RAIL ON THE OPPOSITE HINGE SIDE, SINGLE AND DOUBLE LEAF

Drawing no. 70109-ep02

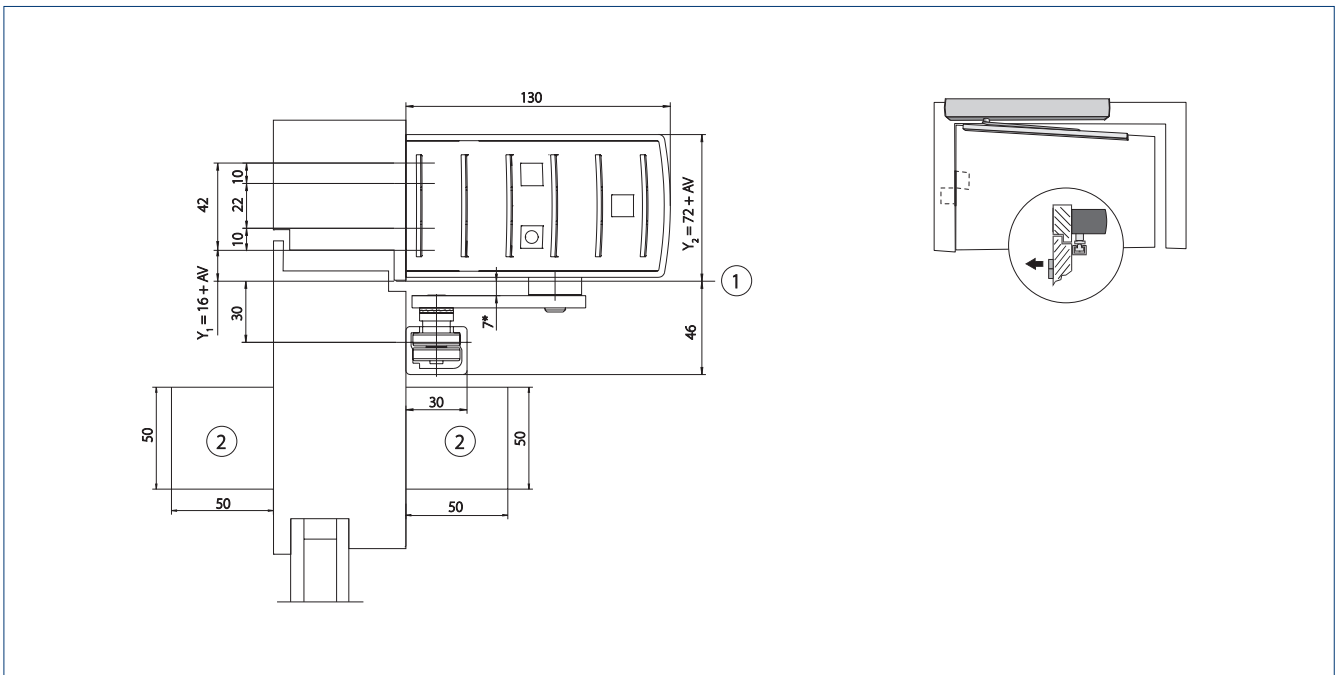

* = Important function dimension | AV = Spindle extension | 1 = Base lower edge of lintel | 2 = Space needed for sensor strips

FITTING DIMENSION MOUNTING PLATE

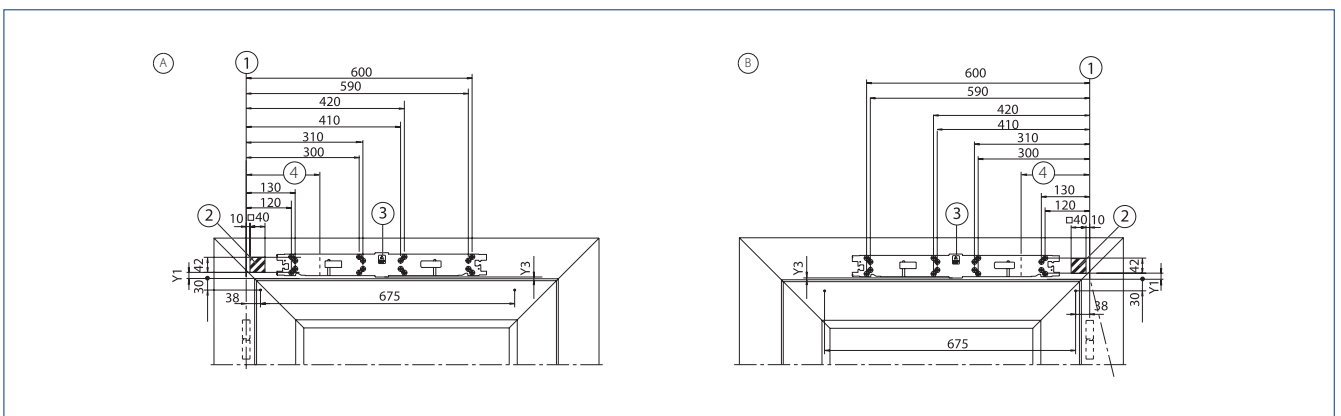

A = DIN left | B = DIN right | 1 = Dimensional reference centre of hinge / door frame bottom edge | 2 = Concealed line-feed possible in the hatched area, e.g. Ø 20 mm for network connection or low-voltage connection | 3 = Orientation arrow for clear positioning of the mounting plate | 4 = Distance centre door hinge-drive axis

DOUBLE LEAF INSTALLATION WITH INTERMEDIATE COVER WITH DIVIDED OR CONTINUOUS COVER

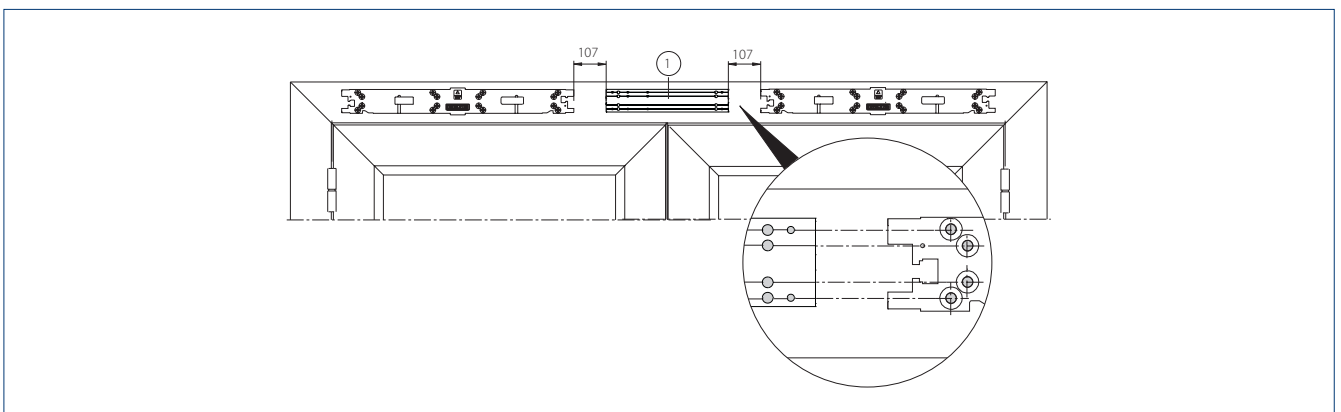

1 = Base plate

DOOR LEAF INSTALLATION WITH ROLLER GUIDE RAIL ON THE HINGE SIDE, SINGLE AND DOUBLE LEAF

Drawing no. 70109-ep03

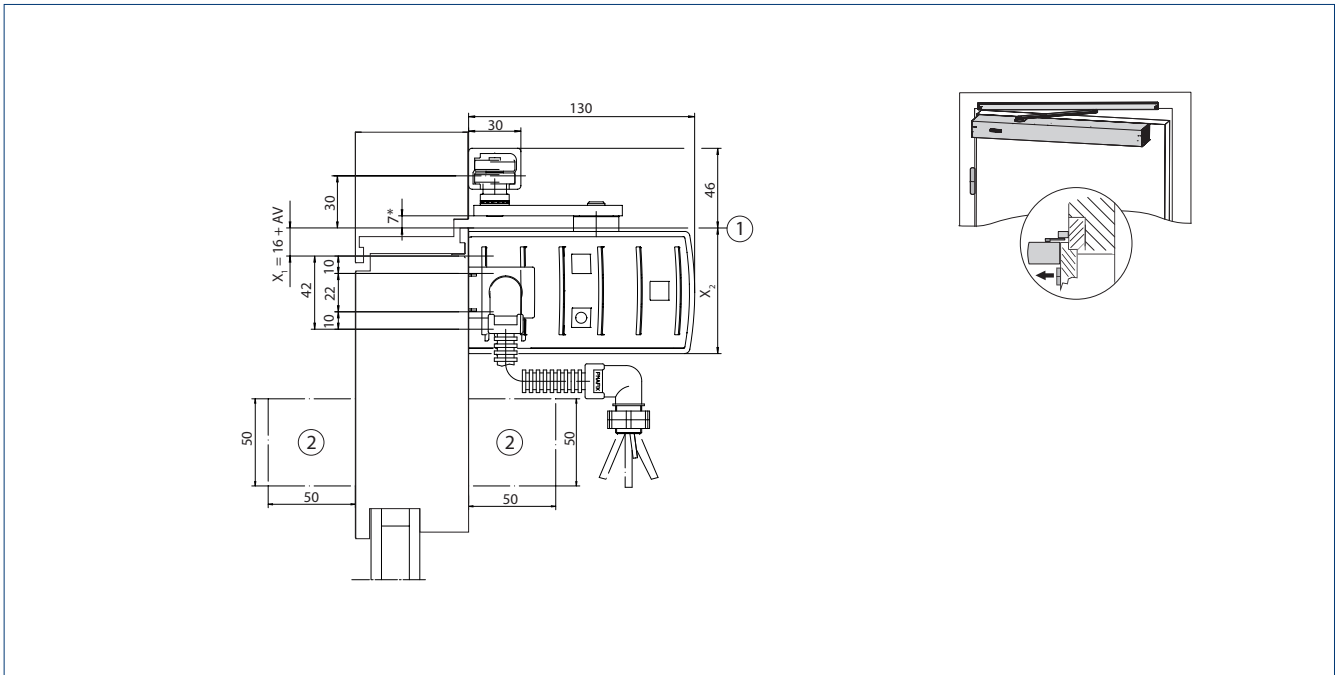

* = Important function dimension | AV = Spindle extension | 1 = Base top edge of door | 2 = Space needed for sensor strips

FITTING DIMENSION MOUNTING PLATE

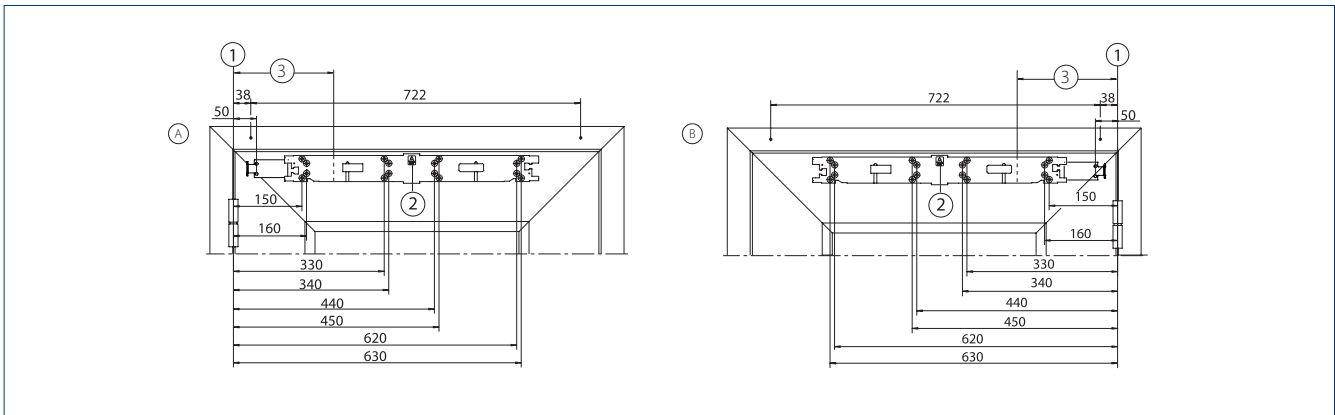

A = DIN left | B = DIN right | 1 = Dimensional reference centre of hinge / top edge of door | 2 = Orientation arrow for clear positioning of the mounting plate | 3 = Distance centre door hinge-drive axis

DOOR LEAF INSTALLATION WITH ROLLER GUIDE RAIL ON THE OPPOSITE HINGE SIDE, SINGLE AND DOUBLE LEAF

Drawing no. 70109-ep04

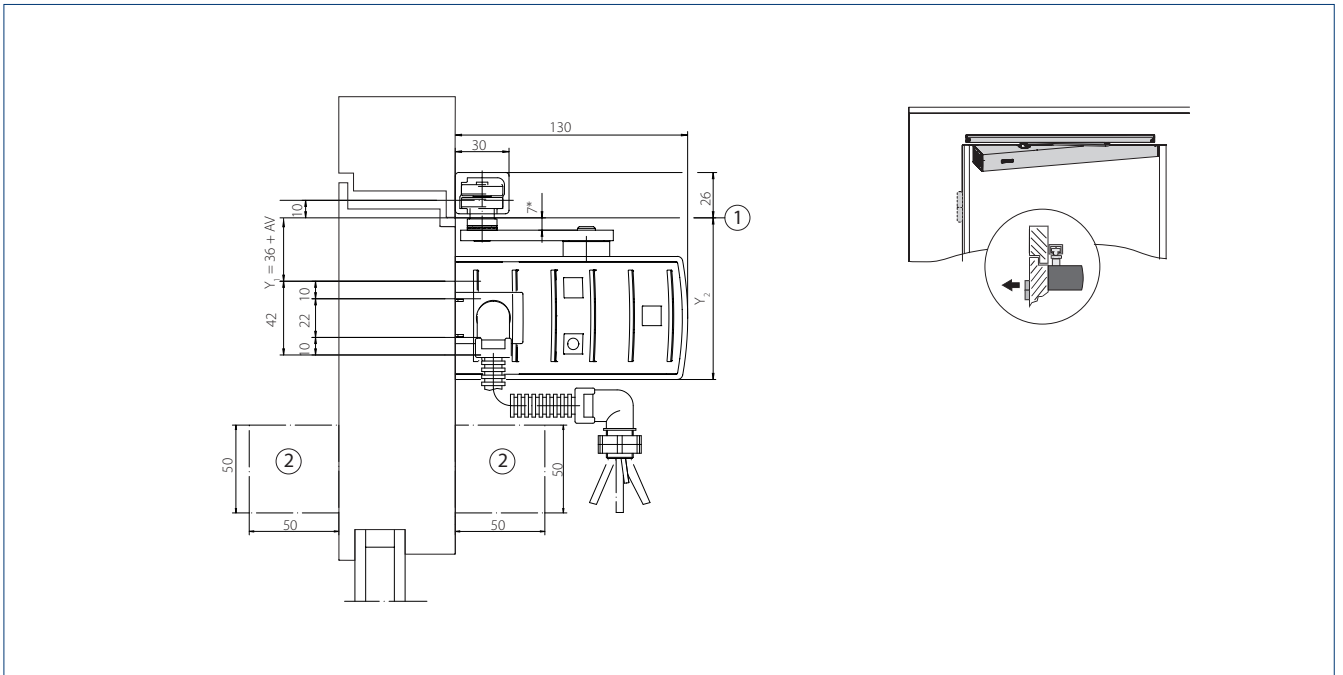

* = Important function dimension | AV = Spindle extension | 1 = Base lower edge of lintel | 2 = Space needed for sensor strips

FITTING DIMENSION MOUNTING PLATE

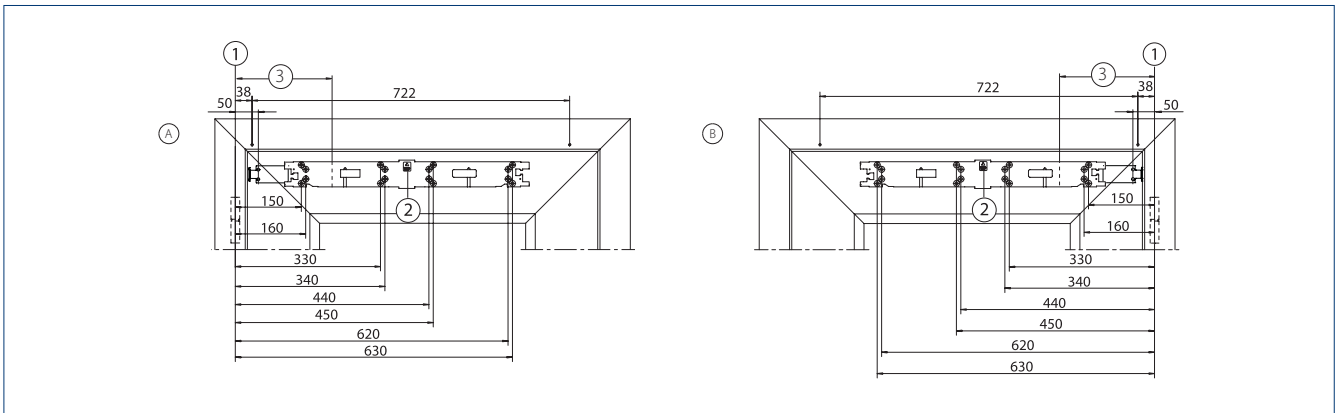

A = DIN left | B = DIN right | 1 = Dimensional reference centre of hinge / door frame bottom edge | 2 = Orientation arrow for clear positioning of the mounting plate | 3 = Distance centre door hinge-drive axis

DOOR LEAF INSTALLATION WITH LINK ARM ON THE HINGE SIDE, SINGLE AND DOUBLE LEAF

Drawing no. 70109-ep06

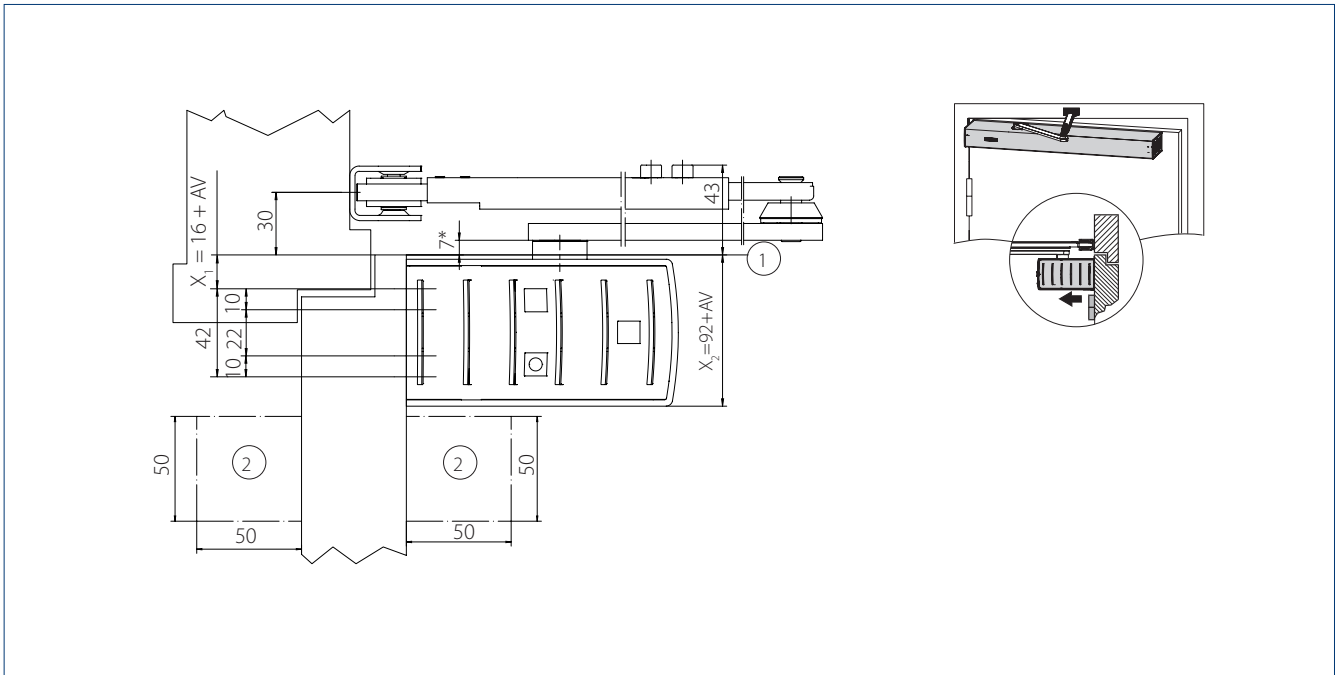

* = Important function dimension | AV = Spindle extension | 1 = Base top edge of door | 2 = Space needed for sensor strips

FITTING DIMENSION MOUNTING PLATE

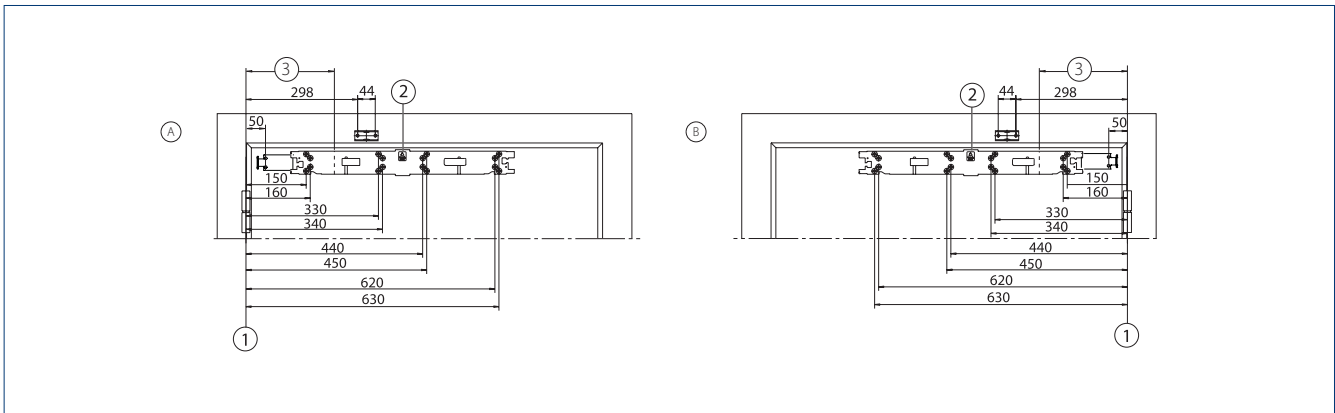

A = DIN left | B = DIN right | 1 = Dimensional reference centre of hinge | 2 = Orientation arrow for clear positioning of the mounting plate | 3 = Distance centre door hinge-drive axis

TRANSOM INSTALLATION WITH LINK ARM ON THE OPPOSITE HINGE SIDE, SINGLE AND DOUBLE LEAF

Drawing no. 70109-ep05

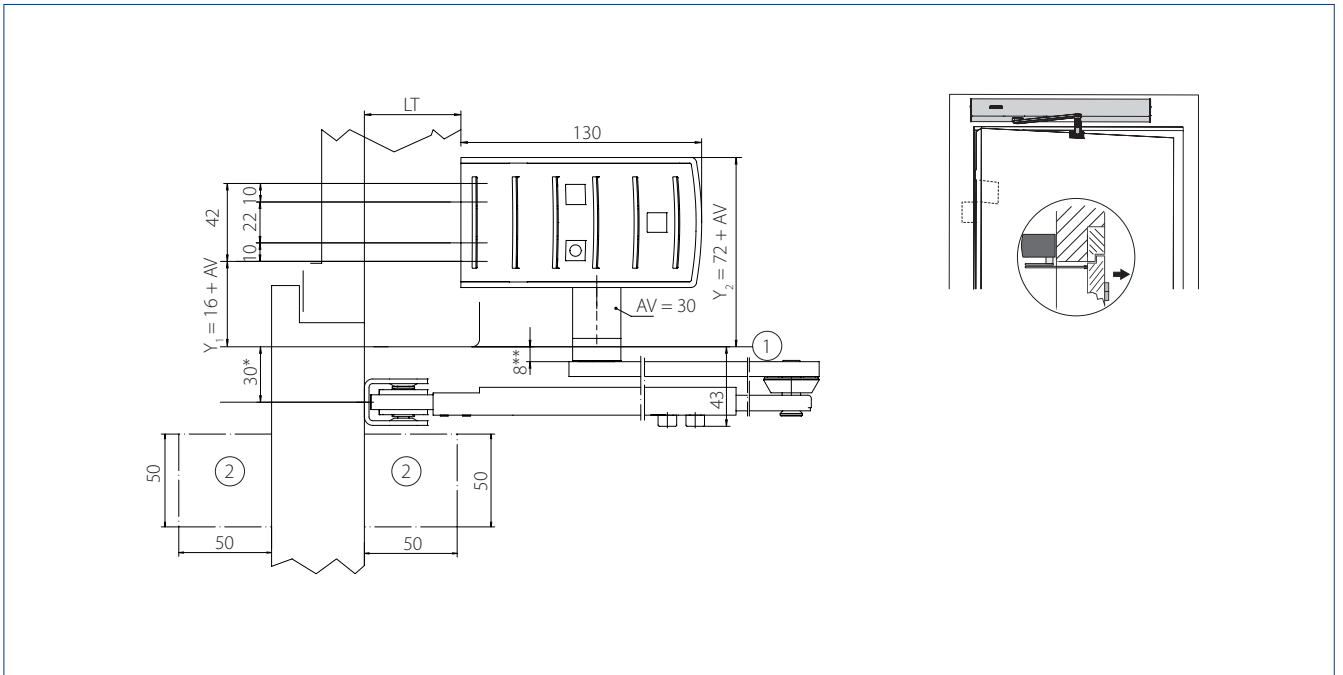

* = With sensor adapter 35,5 mm | ** = Important function dimension | AV = Spindle extension | LT = Reveal depth | 1 = Basic lintel bottom edge | 2 = Space needed for sensor strips

FITTING DIMENSION MOUNTING PLATE

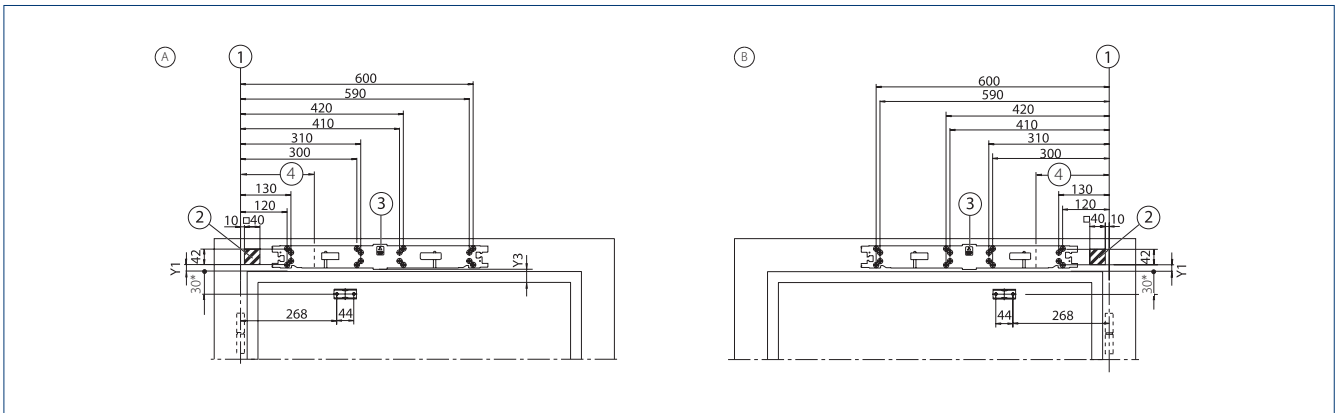

* = With sensor adapter 35,5 mm | A = DIN left | B = DIN right | 1 = Dimensional reference centre of hinge / top edge of door | 2 = Concealed line-feed possible in the hatched area, e.g. Ø 20 mm for network connection or low-voltage connection | 3 = Orientation arrow for clear positioning of the mounting plate | 4 = Distance centre door hinge-drive axis

DOUBLE LEAF INSTALLATION WITH INTERMEDIATE COVER WITH DIVIDED OR CONTINUOUS COVER

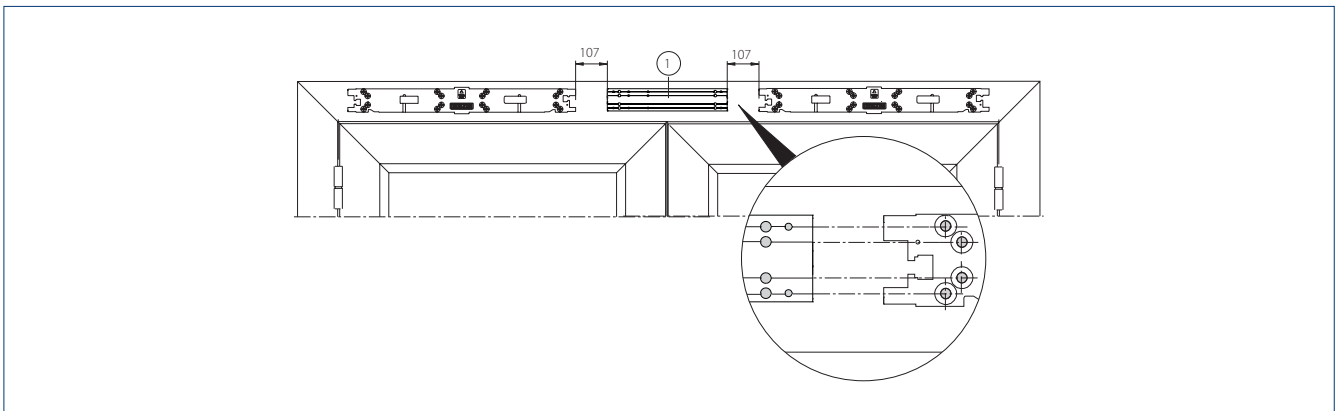

1 = Base plate

POWERTURN IS/TS: TRANSOM INSTALLATION WITH ROLLER GUIDE RAIL ON THE HINGE SIDE, DOUBLE LEAF

Drawing no. 70109-ep21

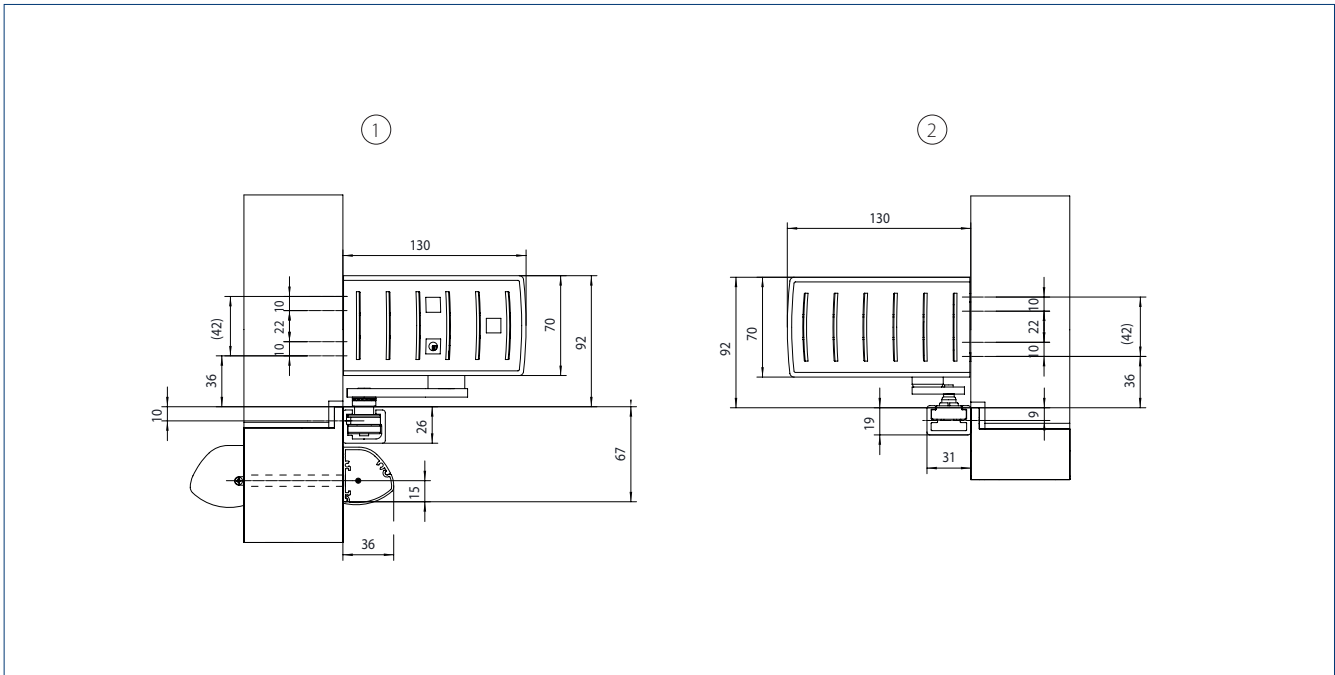

1 = Powerturn with roller guide rail and GC 338 sensor strip | 2 = Door closer TS 5000 L roller guide rail

FASTENING THE MOUNTING PLATE (POWERTURN) AND BASE PLATE (TS 5000 L)

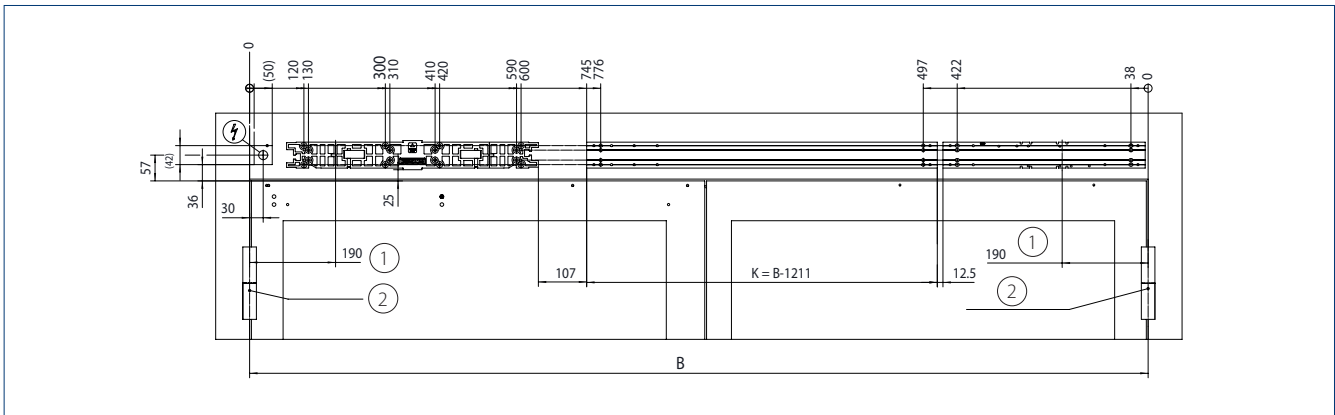

K = Position of the intermediate base plate | B = Hinge clearance | 1 = Distance centre door hinge-drive axis | 2 = Dimensional reference centre of hinge

SIZE OF ROLLER GUIDE RAIL (POWERTURN), GC 338 AND GUIDE RAIL (TS 5000 L)

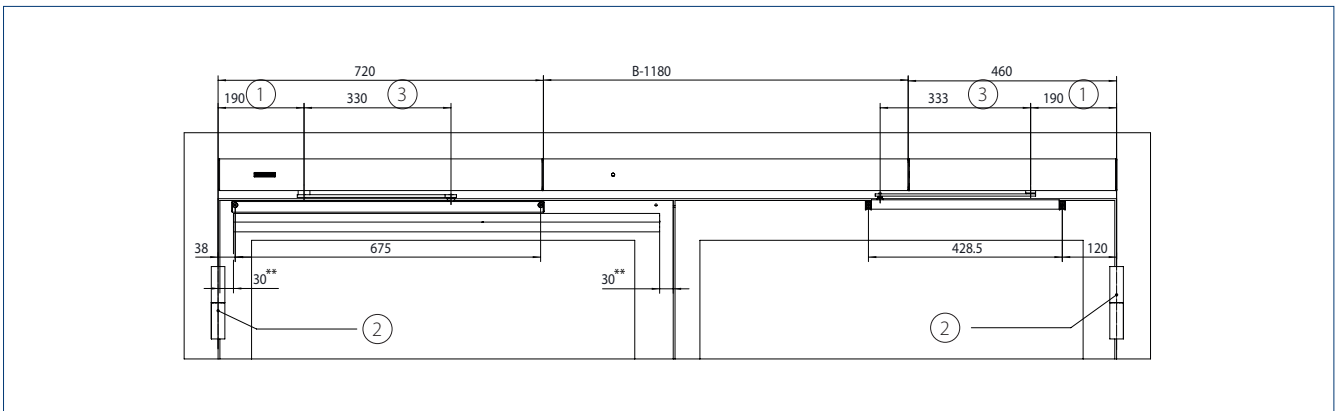

B = Hinge clearance | ** = Recommended size for installation of the GC 335 and GC 338 sensor strip | 1 = Distance centre door hinge-drive axis | 2 = Dimensional reference centre of hinge | 3 = Lever length

LEGEND FOR THE CABLE PLANS

CABLES

1 = NYM-J 3 × 1.5 mm ²
2 = J-Y(ST)Y 1 × 2 × 0.6 LG
3 = J-Y(ST)Y 2 × 2 × 0.6 LG
4 = J-Y(ST)Y 4 × 2 × 0.6 LG
5 = LiYY 2 × 0.25 mm ²
6 = LiYY 4 × 0.25 mm ²
7 = Scope of supply sensor strip or LiYY 5 × 0.25 mm ²
8 = Route empty pipe with pull-wire inner diameter 10 mm

ABBREVIATIONS

HS	Main switch
NOT	Emergency stop switch
UT	CLOSE DOOR manual trigger switch (only for F variant)
KB	Mechanical contact
PS	Programme switch
ST	Emergency stop button
KI	Contact sensor inside
KA	Contact sensor outside
TOE	Electric strike
RM	Bolt message
RS	Smoke switch (only with F variant)
RSZ	Smoke switch control unit (only with F variant)
TS	Door closers
MK	Magnetic contact



Notes:



- Cable plans can also be prepared for specific projects after receipt of order
- Version of standard cable plans in accordance with GEZE specifications
- Wiring in accordance with VDE 0100
- Allow the cable for the drive to project at least 1500 mm out of the wall

1 Door transmission cable (included in the scope of supply for sensor strip), cable guide through a hole in the door leaf is not permitted for fire protection doors. | 2 Cable exit for drive unit, see installation drawings for Powerturn | 3 Cable included in sensor scope of supply | 4 Install close to door | 5 Mains connection box W×H×D min. 65 × 65 × 57 with PG-11 duct, on site | 6 Low-voltage connection box W×H×D min. 94 × 65 × 57 with PG-11 duct, on site | 7 e.g. Door transmission cable 8-wire, mat.no. 066922 | 8 Branch box, on site

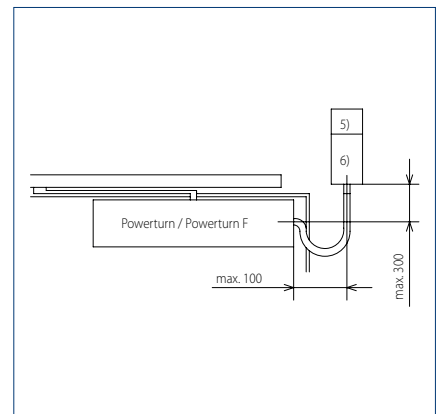
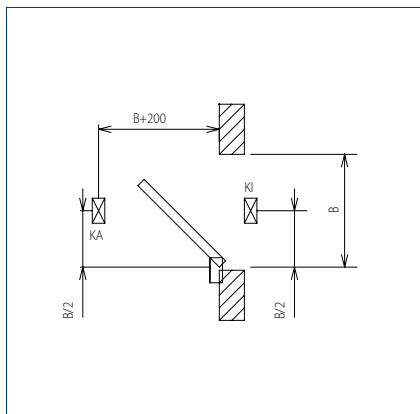
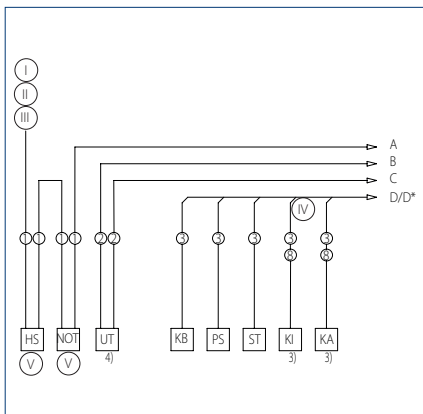

I = Power supply circuit 230 V / 50 Hz | II = Safety fuse 10 A | III = Connection value 200 W, 1 A single, double leaf with manual passive leaf; connection value 400 W, 1 A for double leaf | IV = And / Or | V = Option

SINGLE LEAF

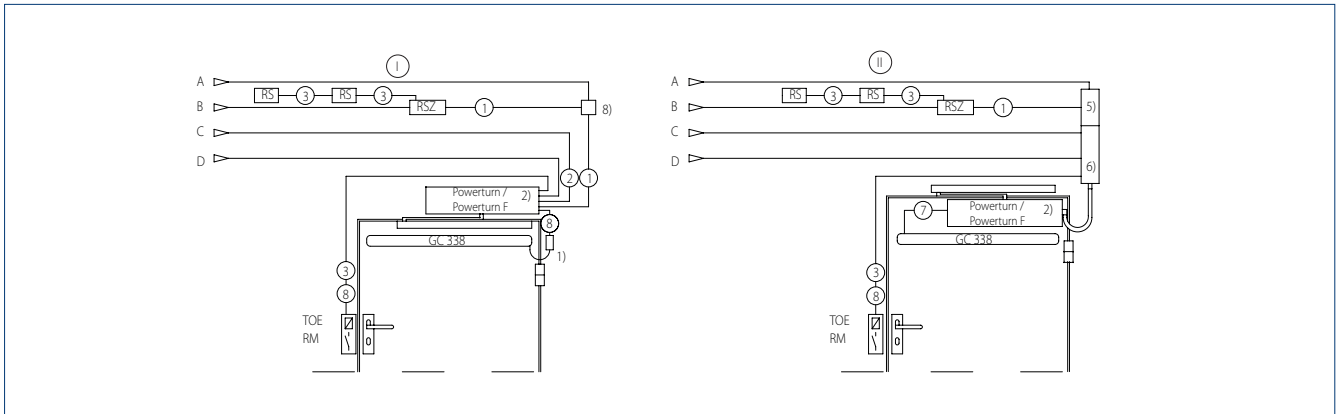

DOUBLE LEAF

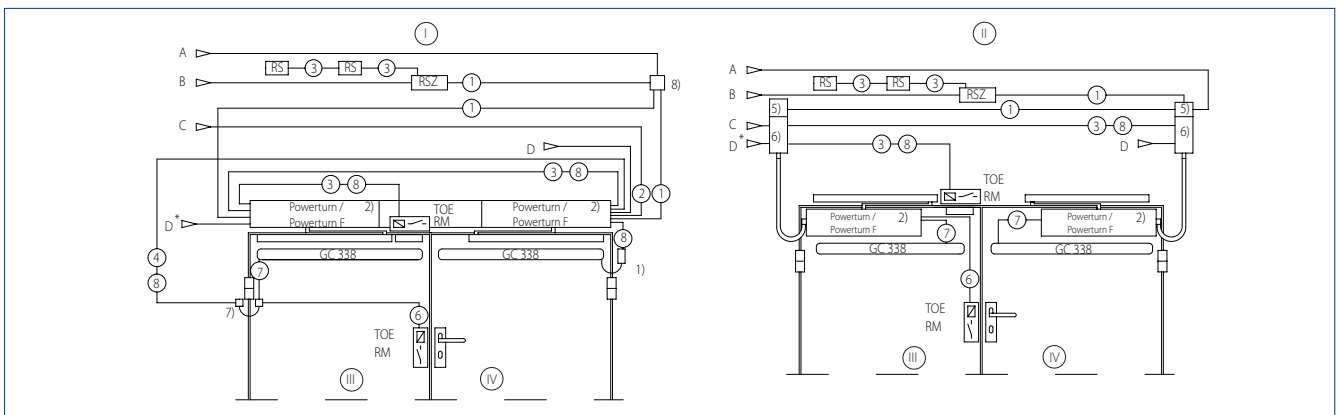

I = Transom installation | II = Door leaf installation | III = Passive leaf | IV = Active leaf



SWING DOOR

Accessories

Even safer, more convenient and more individual – be inspired by our range of accessories for your particular needs or the specific installation situation of your swing door system. From mounting plates and roller guide rails to a variety of switches and push buttons to many more service tools – we are happy to help you with questions and choosing products regarding your automatic swing door systems.

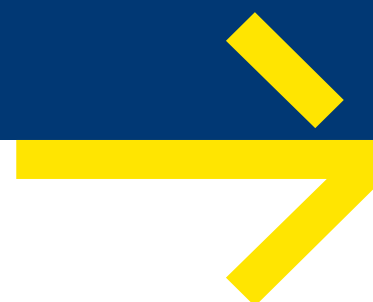

Cover, mounting plate, link arm, roller guide rail

COVER

The cover is available in an anodised or coloured finish. In the case of double leaf versions, the cover can be ordered as a continuous variant or with intermediate cover.

MOUNTING PLATE FOR DRIVES (OPTION)

A mounting plate may be necessary, depending on the installation situation. A mounting plate is generally recommended to make installation easier.

A respective mounting plate is available according to the cover version.

LINK ARMS

are offered for different reveal depths.

ROLLER GUIDE RAIL WITH LEVER

Installation depends on the type of installation chosen.



Cover



Mounting plate



Link arm



Roller / guide rail with lever

Operating automatic swing doors

PROGRAMME SWITCHES FOR SELECTION OF THE MODE OF OPERATION FOR AUTOMATIC SWING DOORS

GEZE offers programme switches for a wide range of individual demands. The switches are suitable for universal use – for surface-mounted or flush-mounted installation. The following switch types are available:

DISPLAY PROGRAMME SWITCH (DPS)

KEYPAD PROGRAMME SWITCH (TPS)

MECHANICAL PROGRAMME SWITCH (MPS)

The following modes of operation can be set:

- **"Hold open"**
The door moves to the OPEN position and remains open. Movement detector or opening push button are deactivated.
- **"Night"**
The movement detectors are switched inactive, the door closes. The door can only be opened with a mechanical contact (KB) or manual release. Option: The door leaves are locked electrically to prevent forced opening.
- **"Exit only" (one-direction operation from the inside to the outside)**
The door only opens and closes when someone goes out from the inside. The movement detector outside is switched inactive, the one inside is switched active.
- **"Automatic"**
The door opens as soon as it is activated via the movement detector or keys, and closes after a certain time that can be individually adjusted. Safety sensors protect the leaves' travel path. If there is someone in the door opening, the door will not close.
- **"OFF" (depending on the model)**
Drive motor, locking mechanism, activation and safety sensors are switched off, the door leaves can be opened manually.
- **Key switch**
The programme switch can be disabled using a key switch.

PROTECTION OF THE PROGRAMME SWITCHES

The mechanical programme switch (MPS) is also available in a lockable version. The display programme switch (DPS) and keypad programme switch (TPS) can be combined with a key switch. Alternatively, the DPS and TPS can also be secured using a code.



Display programme switch (DPS)



Keypad programme switch (TPS)



Mechanical programme switch (MPS)

- **Note:** More detailed information about the following accessories can be found in the catalogue: **GEZE activation devices and sensors**

Automatic activation

RELIABLE ACTIVATION WITH GEZE SENSORS

RADAR MOVEMENT DETECTOR

Radar movement detectors register all objects that move within the radar field. All movements within the radiation range are recorded as a switching pulse which is forwarded as a door opening signal. The pre-programmed convenience setting of the GEZE radar movement detectors ensures they can be put into operation quickly. Automatic configuration is possible via keys or a remote control. Reliable detection is achieved with a clearly defined radar field. Energy can be saved through detection of people's direction of movement. Unwanted door opening is avoided since cross-traffic can be faded out.



GC 308 radar movement detector



GC 302 radar movement detector

Manual activation

PUSH BUTTONS AND SWITCHES

GEZE push buttons and switches for the wireless activation of doors – reliable, convenient and safe at the push of a button.

CAPACITIVE PUSH BUTTON

The design-oriented and sturdy LED sensor switch makes intuitive and straightforward operation possible. No great efforts are needed for activation – touching the button slightly is sufficient. Suitable for indoor and outdoor use, the LED sensor switch can be recognised easily in the dark thanks to the blue LED lighting. In addition, the sensor has Braille lettering on it. A visual signal signalises activation through the push button. The push button is waterproof, impact-resistant and protected against vandalism. This makes it very well suited for outdoor use or installation in the floor.

NON-CONTACT PROXIMITY SWITCH

With the GC 307+, interior doors without a haptic perception requirement can also be activated cleanly and comfortably. The sensor ensures bacteria-free access to toilets, for example, or germ-free conditions in hotel kitchens, swimming pools and doctors' surgeries. The pulse generator is installed at hand height and precisely detects people and objects – independently of their direction of movement – both in the direct vicinity of only 10 cm, as well as 60 cm away. The different scanning ranges can be optimally adapted to existing environmental conditions and the interests of the user groups. The non-contact sensors offer a high level of operating comfort – people only need to approach them to trigger the automatic opening mechanism – and the advantage of absolute hygiene. The optimum system structure permits simple and time-saving installation in the flush-mounted box. The colour of the LEDs can be adjusted, and individual pictograms can also be applied to illustrate the area of application.

WIRELESS ACTIVATION

GEZE radio transmitter are used for wireless activation of doors and windows as a multi-channel solution. For every additional channel, an additional electrical device or function can be switched at the push of a button. Thanks to the very small size of the wireless modules, radio transmitter can easily be integrated in the drive or in a flush-mounted box. They can also be clipped directly into the elbow switch and mounted without wires, e.g. on glass.



Push button

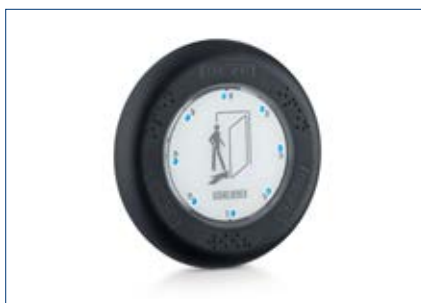

LED sensor switch



GC 307+ non-contact proximity switch



Wireless activation



Plastic elbow switch



Elbow switch stainless steel IP65

Protection

THE RIGHT CHOICE OF PROTECTION

The GEZE product range of safety sensors offers the right solution for every door situation and every type of use. Because the choice of safety sensors is an important factor in enabling you to operate automatic doors providing barrier-free access conveniently, reliably and economically, and to adapt their functionality to users' needs in the best way possible.

Sensor strips are the right choice for standard door situations with door widths up to 1200 mm and door heights up to 3500 mm. A more compact and universal design, particularly on doors with narrow frames, is achieved via the GC GR sensor roller guide rail or sensor and link arm adapter.

From a visual perspective, we recommend the combination of a GC 338 sensor on the wide door leaf and a GC 335 on the narrow door leaf on asymmetrical double leaf door systems with passive leaf widths below 600 mm.

If an automatic door with vertical push-bars, or a door width exceeding 1200 mm is planned, the GC 342 / GC 342+ laser scanners offer more cost-effective protection. Depending on the door configuration and door environment, it can mean a time saving of up to 50% for the engineer with respect to installation and commissioning.

If the appearance, or protecting the cabling between the sensor and drive is important, the drip loop can be concealed on all drive units and sensors. The cable from the sensor to the drive is guided between the door leaf and the door frame by a drip loop.

SAFETY WIDTHS OF SWING DOOR SENSORS:

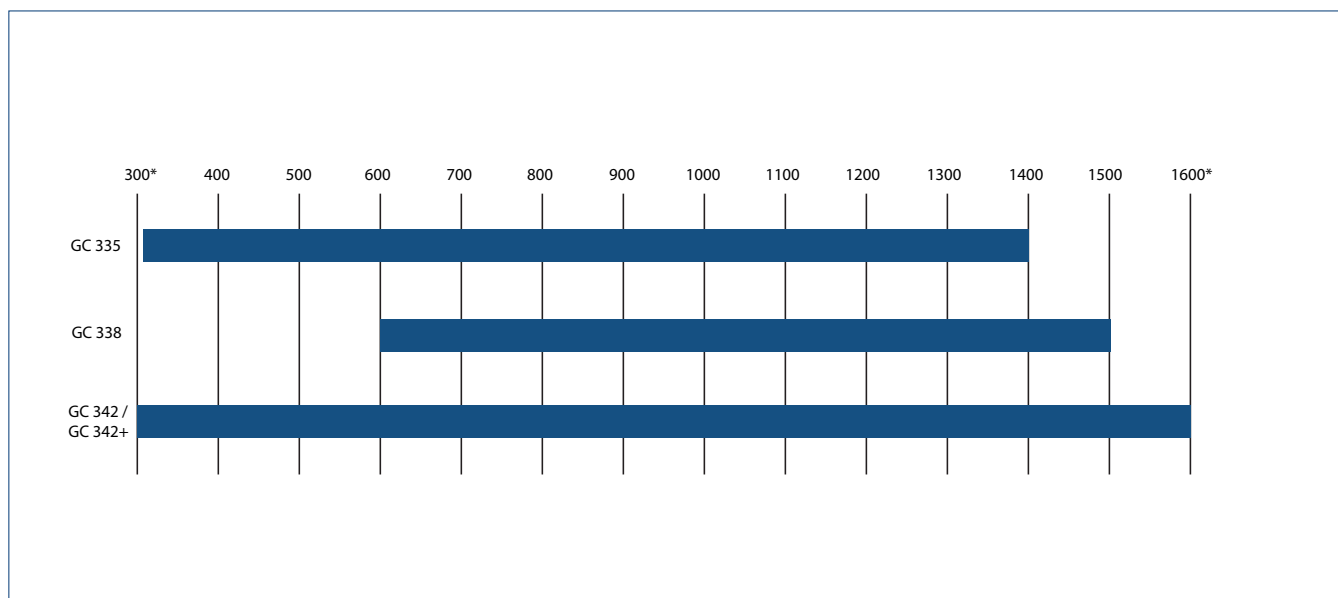

* = min./max. door width dependent on drive

GC 342 / GC 342+ LASER SCANNERS

The compact and space-saving GC 342 and GC 342+ laser scanners are used for the protection of automatic swing doors in accordance with EN 16005 / DIN 18650. The sensors are mainly used with difficult floor conditions (e.g. entrance mats, metal rails, dark and light-absorbing floor coverings). The close-meshed detection field with a large detection area over the whole door width provides special protection at the primary and secondary closing edges.

In addition, the sensors have a wall blanking feature which makes it possible to guarantee maximum safety even with doors that open against walls, radiators, windowsills, or similar. The sensors automatically teach themselves their environment. Protection of all GEZE swing door drives with door leaf widths of up to 1600 mm is achieved with only one sensor system.

The installation on the upper edge of the door near the hinge is cleverly solved and therefore is quick and easy to achieve. The door leaf width to be protected is taught-in using hand movements. Settings, such as position of the master module on the hinge side/opposite hinge side, immunity, background monitoring and monitoring of the secondary closing edge can be conveniently adjusted using the DIP switch.

In comparison to the GC 342, the GC 342+ laser scanner has four detection areas. The GC 342+ is primarily mounted on the opposite hinge side. The four detection areas make it possible to protect a large area when the door is open. The door only closes once the door swing range is clear to the frame. The innermost curtain runs vertically along the door leaf at 0°, and significantly increases protection of the secondary closing edge – mechanical finger protection can be eliminated. Finally, the GC 342+ has a separate output for non-contact and hygienic opening at hand or foot height, for instance. Two freely-definable virtual fields can be taught in at any height.



GC 342 laser scanner



GC 342+ laser scanner

GC 338 SENSOR STRIP

The energy and space-saving GC 338 sensor strip has a very large safety range and offers enhanced protection on the primary and secondary closing edges. In addition, the sensor has a wall blanking feature which makes it possible to guarantee maximum safety even with doors that open against walls. Protection of all GEZE swing door drives with door leaf widths of up to 1500 mm is achieved with only one sensor system. GC 338 not only offers advantages for installation and commissioning – the complete door system is supplied via an interface. The sensor automatically adapts to its environment. This saves teach-in time and installation costs. The GC 338 sensor strip has the following features:

- Reliable function under all weather and floor conditions up to 3.5 m in accordance with DIN 18650 / EN 16005
- One sensor system protects door leaf widths up to 1500 mm
- Wall blanking: The sensor can detect a wall and blank it out automatically
- Attractive roller guide rail can even be used with slim door profiles
- Current consumption in operating mode: 200 mA
- Quick and easy installation thanks to the SNAP IN mechanism. With its help, modules can be positioned and secured in the profile without tools



GC 338 sensor strip

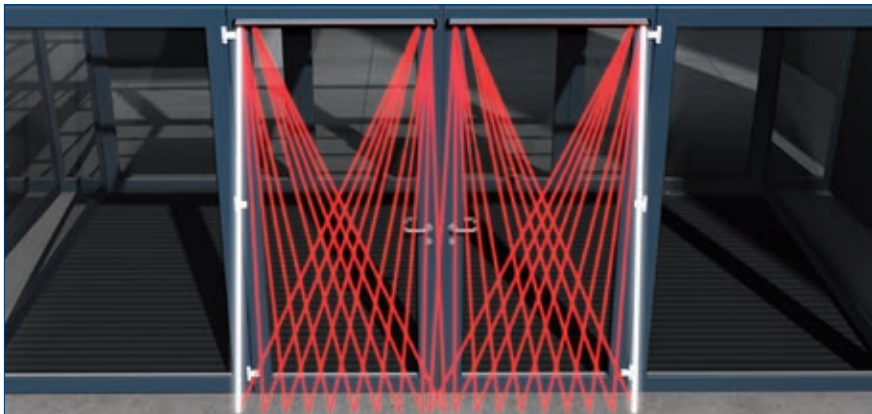

Frontal detection field



Wall protection

INSTALLATION ON DOORS WITH VERTICAL PULL HANDLES AND/OR DOOR WIDTHS >1200 MM

The GC 342 laser scanner is generally recommended for protection in accordance with the standards DIN 18650/ EN 16005.

GC 342 reduces installation and commissioning by up to 50% compared with sensor strips.

GC GR SENSOR ROLLER GUIDE RAIL – THE IDEAL COMBINATION OF SAFETY AND DESIGN

The GC GR sensor roller guide rail is available for the complete Slimdrive EMD drive series and all Powerturn drive variants. The sensor and the roller guide rail can be put together in such a way that they look like a single component. This means it can be mounted together with the safety components even on narrow door profiles. The result is an even more compact and more integrated design. The features at a glance:

- Suitable for single and double leaf swing doors
- Available for all Slimdrive EMD and Powerturn variants and roller guide rails
- Sensor and roller guide rail profile are available separately, facilitating retrofitting to existing systems
- A rain cover is available as an accessory

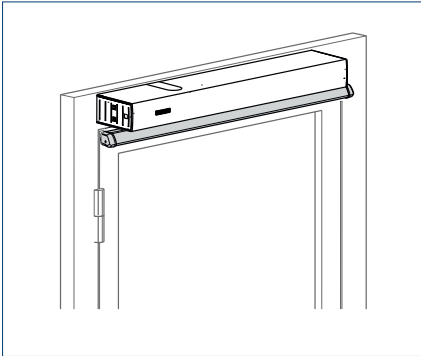

GC GR sensor roller guide rail



ADAPTER FOR SENSOR AND LINK ARM FOR SLIMDRIVE EMD AND POWERTURN – INTEGRATION OF LINK ARM AND SENSOR STRIPS ON ONE LEVEL

Exactly similar as in case of the GC GC sensor roller guide rail, the adapter for link arm and sensor enables an optimal installation on doors with narrow frames. Benefits:

- Better integration of link arm and sensor strip in the door design
- Simple installation, especially for narrow door frames

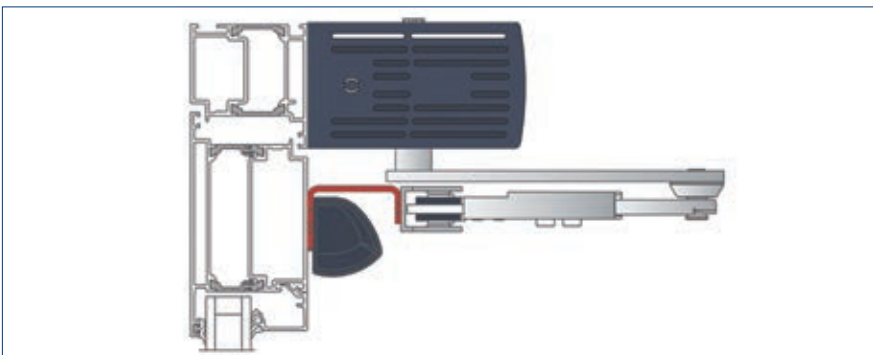

Adapter for sensor and link arm for Slimdrive EMD and Powerturn swing door drives



EMD AND GC GR (GC 338) TRANSOM INSTALLATION WITH ROLLER GUIDE RAIL ON THE HINGE SIDE

Drawing no. 70106-ep35

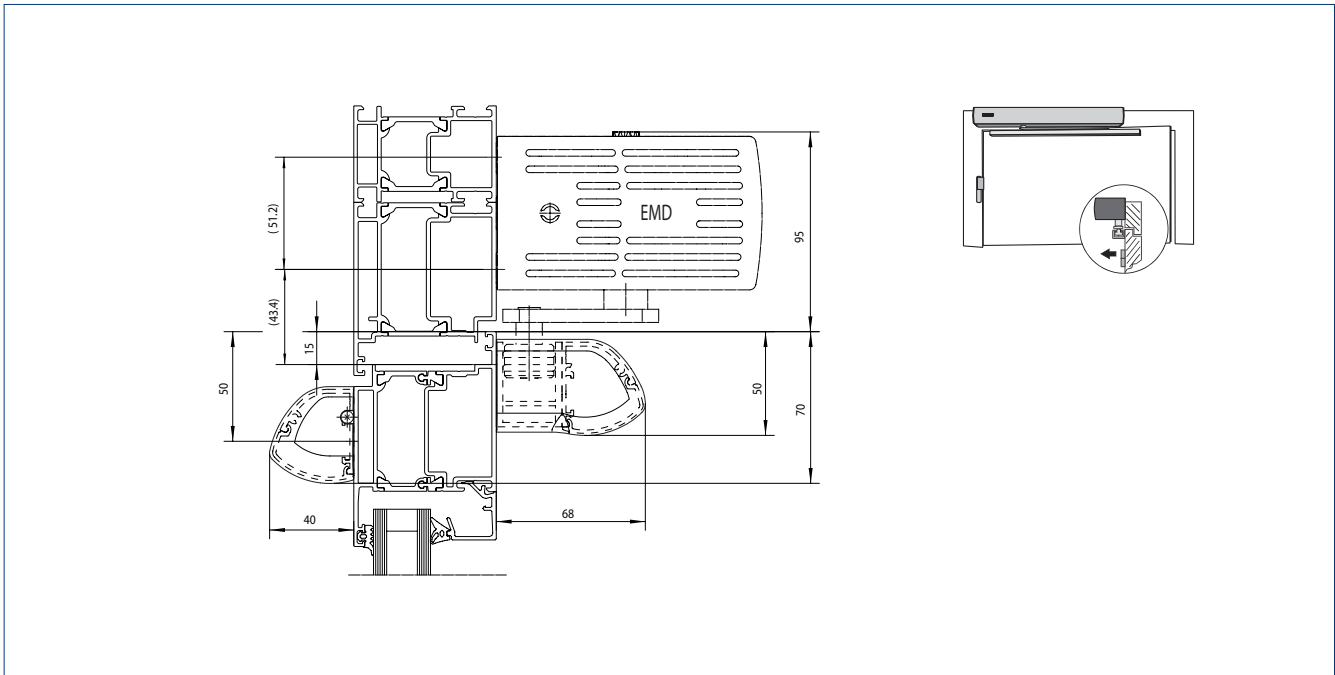

EMD AND GC GR (GC 338) TRANSOM INSTALLATION WITH ROLLER GUIDE RAIL ON THE OPPOSITE HINGE SIDE

Drawing no. 70106-ep35

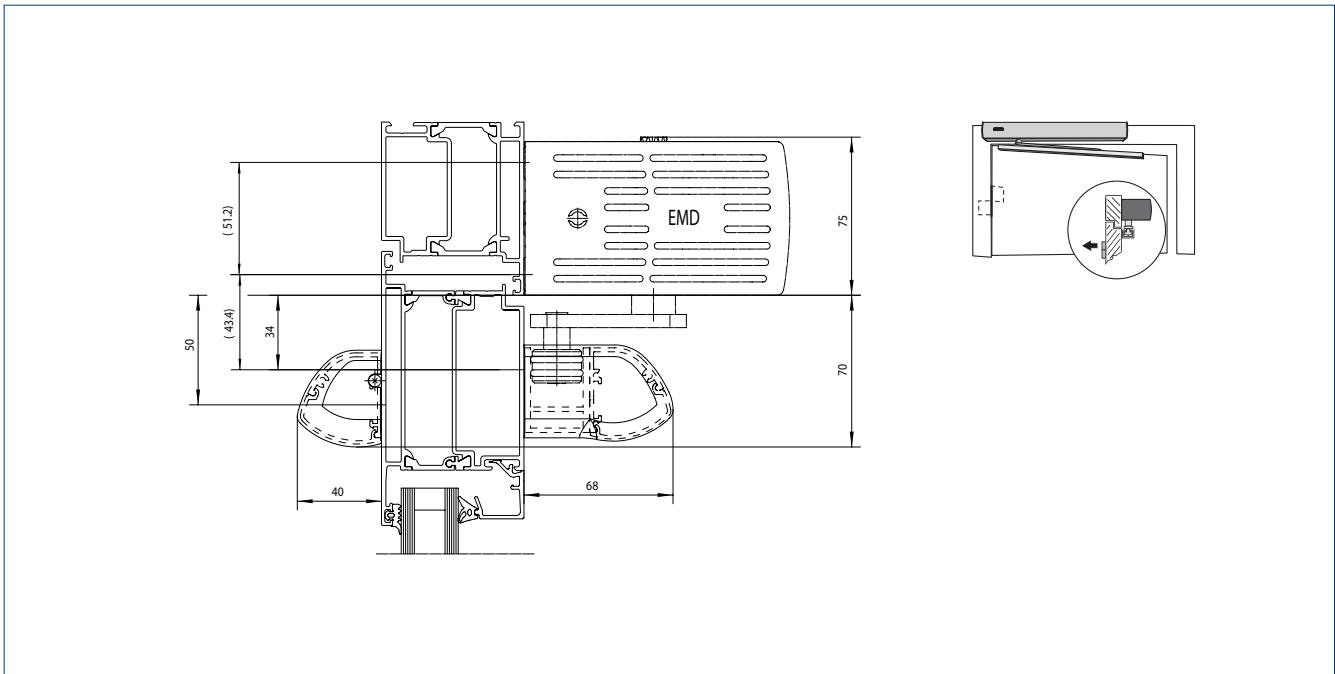

GC GR (GC 338) 1200 MM WITH ROLLER GUIDE RAIL, SINGLE LEAF

Drawing no. 70106-ep35

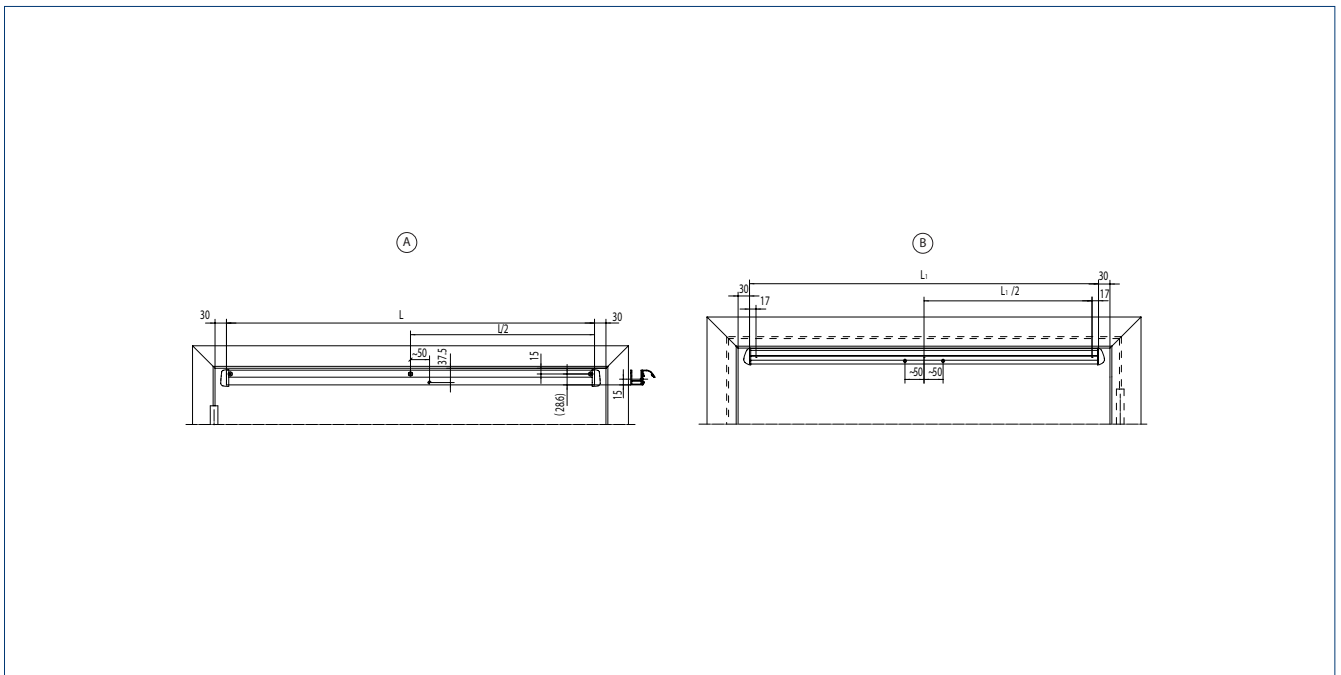

A = Hinge side | B = Opposite hinge side | L = Length

→ **Note:** For double leaf doors, additionally mirror this view.

Service tools

GEZE SERVICE APPS

myGEZE Connects and GEZEconnects enable a wireless connection via Bluetooth between a computer and GEZE automatic door systems. All settings for the door system can be conveniently configured, saved, sent by email and transferred as a log file via an intuitive graphical user interface. Diagnosis functions show the most important function parameters of the door system in real time, so that faults are recognised at a glance and can be eliminated. All the pre-settings can be taken over very easily for further door systems. The convenient documentation of commissioning, maintenance and diagnosis protocols as well as all statistical data can easily be downloaded at any time. Password protection to block operating parameters and servicing data guarantees there will be no unauthorised modifications.

ST 220 SERVICE TERMINAL

Mobile, handy and straightforward – that is parameter setting for the automatic GEZE door systems using the ST 220 service terminal. Communication and data exchange between the service terminal and the drive unit is via an integrated RS485 interface. The large illuminated display is easy to operate thanks to the plain text display. The service terminal is equipped with a readout function for servicing and diagnosis work. Power is supplied via the door system. Password protection to freeze operating parameters and servicing data guarantees there will be no unauthorised modifications made.

A service adapter for the ST 220 or a service adapter for the bluetooth interface which is available separately can be inserted into the side of the Powerturn drive models, thus permitted operating parameters and service data to be read out and parameters to be set without the drive cover having to be removed.



Notes:



- GEZE Service Apps are available for the drive series Slimdrive EMD and Powerturn.
- Changes to parameters on GEZE drives may only be carried out by experts authorised by the manufacturer (GEZE) in accordance with DIN 18650/EN 16005



GEZEconnects



myGEZE Connects



myGEZE Bluetooth module



ST 220 service terminal



Service adapter for ST 220



Service adapter Bluetooth interface





SWING DOOR

References

Discover a selection of innovative buildings which we were able to equip with our automatic swing door systems. Customers all over the world have praised the diverse functions and elegant design: Be it a first-class hotel, a state-of-the-art hospital, a representative retirement home, a renowned museum, an elegant administrative building or a heavily frequented station – the products and services by GEZE for automatic swing doors are the first choice. We provide convenient and reliable drive units.





Ecturn Inside swing door drive, private house (photo: Lazaros Filoglou / GEZE GmbH)

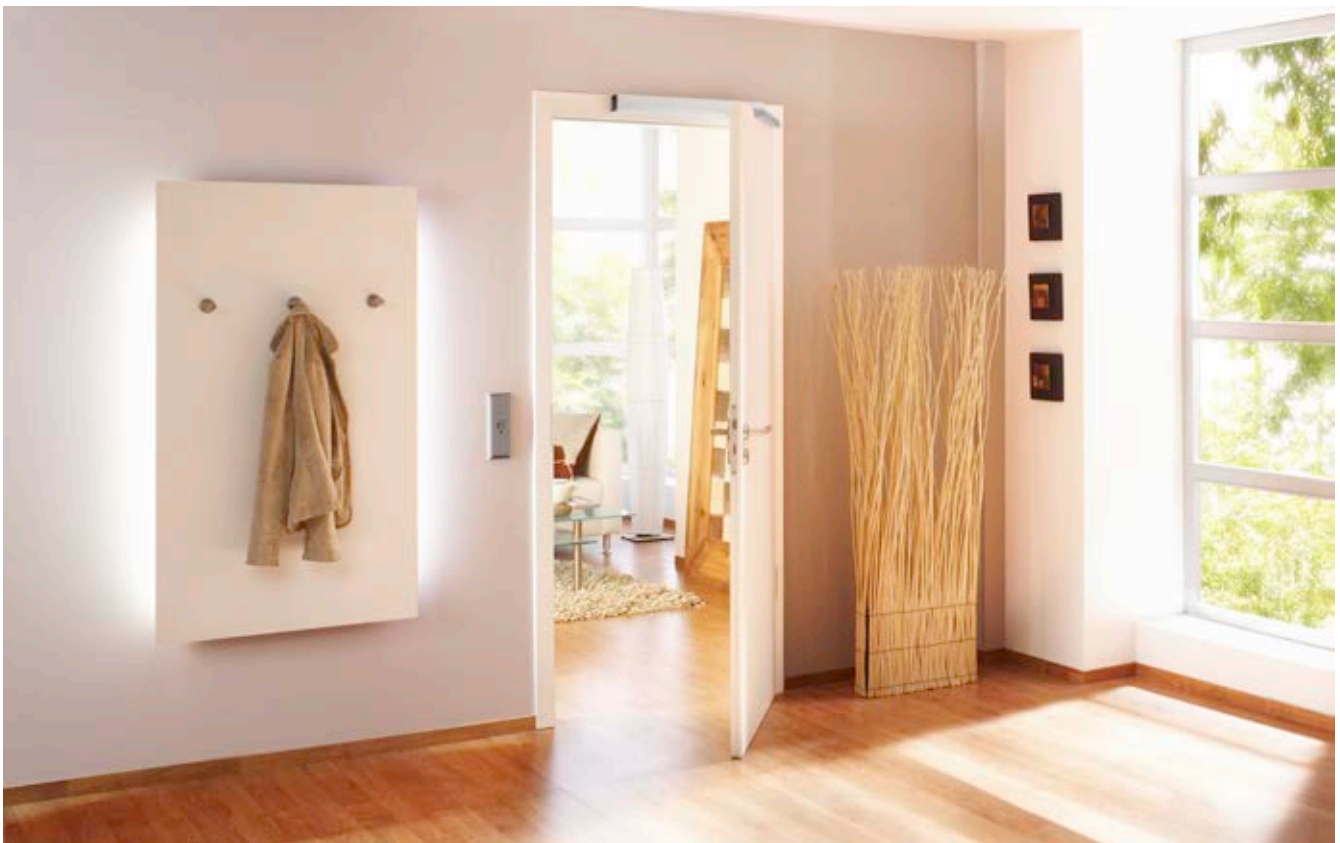

Ecturn swing door drive with LS990 elbow switch (photo: Studio BE / GEZE GmbH)



Powerturn swing door drive with GC 342 laser scanner and TZ 320 door control unit, experimenta Heilbronn, Germany (photo: Jürgen Pollak / GEZE GmbH)



Powerturn swing door drive F/R with LS 990, Rathaus Leonberg, Germany (photo: Jürgen Pollak / GEZE GmbH)



Powerturn swing door drive with GC 338 sensor strip, experimenta Heilbronn, Germany (photo: Jürgen Pollak / GEZE GmbH)



Slimdrive EMD-F swing door drive with TZ 320 emergency exit control unit, Olghospital Stuttgart, Germany (photo: Jürgen Pollak/GEZE GmbH)



Slimdrive EMD F-IS swing door drive and GC 338 sensor strip, Klinikum Düsseldorf, Germany (photo: Lothar Wels/ GEZE GmbH)

We are GEZE.

For liveable buildings

GEZE stands for innovation, high quality and comprehensive support of building technologies. From the initial idea, planning and operational implementation with standard products to customised system solutions and individual service and maintenance plans. We offer an extensive product range of door, window and safety technology products and are a major driving force behind the digital networking of building automation.

GEZE GmbH

Reinhold-Vöster-Straße 21 – 29

71229 Leonberg

Deutschland

Telefon: +49 7152 203 0

Telefax: +49 7152 203 310

E-Mail: info.de@geze.com

www.geze.com