

GEZE



SLIDING DOOR

# Automatic sliding door

# Contents

Overview	4
----------	---

---

## STANDARD SLIDING DOOR SYSTEMS

---

ECdrive T2	11
Slimdrive SL NT	24
Powerdrive PL	30

---

## SLIDING DOOR SYSTEMS SPECIAL VARIANTS

---

Slimdrive SLT	41
Slimdrive SL RC2	48
Slimdrive SL-BO	54
Slimdrive SL-T30	57
Slimdrive SLV	58
Slimdrive SL inclined	60

---

## SPECIAL FUNCTIONS ESCAPE AND RESCUE ROUTES

---

Redundant sliding doors for escape and rescue routes with locked exit only function (FR-LL)	64
Redundant sliding doors for escape and rescue routes in both directions (FR-DUO)	65
Redundant sliding doors for locked escape and rescue routes (FR-RWS)	66
Sliding doors for escape and rescue routes according to CO48 (France)	67

---

**SOLUTIONS AND FUNCTIONS**

Accessible toilet	70
Vestibule systems	71

**SLIDING DOOR FITTINGS**

Fitting variants	74
------------------	----

**ACCESSORIES**

Operation of automatic sliding doors	78
Automatic activation	79
Manual activation	80
Electronic protection	82
Mechanical protection	83
Locking mechanisms	84
Service tools	87

<b>CABLE PLAN</b>	90
-------------------	----

<b>REFERENCES</b>	94
-------------------	----

**OVERVIEW TABLE FOR AUTOMATIC SLIDING DOOR SYSTEMS**

	ECdrive T2	Slimdrive SL NT	Powerdrive PL
<b>PRODUCT FEATURES</b>			
Dimensions (height x depth)	100 x 190 mm	70 x 190 mm	150 x 185 mm 200 x 185 mm
Opening width 1-leaf	700 – 3000 mm <sup>4</sup>	700 – 3000 mm	700 – 3000 mm
Opening width 2-leaf	900 – 3000 mm	900 – 3000 mm	800 – 3000 mm
Leaf weight (max.) 1-leaf	120 / 140 kg <sup>3</sup>	125 kg	200 kg <sup>1</sup>
Leaf weight (max.) 2-leaf	2 x 120 / 140 kg <sup>3</sup>	2 x 125 kg	2 x 180 kg <sup>1</sup> 2 x 200 kg <sup>2</sup>
Opening / closing speed (max.)	0.8 / 0.8 m/s	0.8 / 0.8 m/s	0.8 / 0.8 m/s
Redundant sliding doors for escape and rescue routes (FR)	●	●	●
<b>SPECIAL FUNCTIONS ESCAPE AND RESCUE ROUTES</b>			
FR with exit only locked (FR-LL)	●	●	●
FR in both directions (FR-DUO)	●	●	●
FR locked (FR-RWS)	●	●	●
CO48 (France)	●	●	●
<b>FITTING VARIANTS</b>			
ISO glass fine-framed	●	●	●
MONO glass fine-framed	●	●	●
GCprofile Therm, energy-efficient profile system fine-framed	●		
Toughened safety glass clamping fitting fine-framed	●		●
All-glass system (GGS)		●	
Integrated all-glass system (IGG)		●	

● = Yes | 1 = max. 160 kg for FR variant, max. 120 kg for fine-framed leaves and profile system GCprofile Therm | 2 = if applicable increased opening and hold-open times | 3 = 120 kg with single roller carriage (standard), 140 kg with double roller carriage (option) and GCprofile Therm | 4 = 700 – 1500 mm for GCprofile Therm profile system



Trendpark Neckarsulm sliding door drive (photo: Martin Jakob / GEZE GmbH)



Cologne Bonn Airport (photo: Martin Jakob / GEZE GmbH)





SLIDING DOOR

# Standard sliding door systems

You want to save space, but not at the cost of a comfortable atmosphere. You want to offer barrier-free access to all users, but not at the cost of a lack of safety. We have the ideal solution ready for you with our automatic sliding doors. Be it for office buildings, airports, hotels or schools. And you can rest assured where safety is concerned: All GEZE automatic door systems and safety sensors meet the European EN 16005 standard.

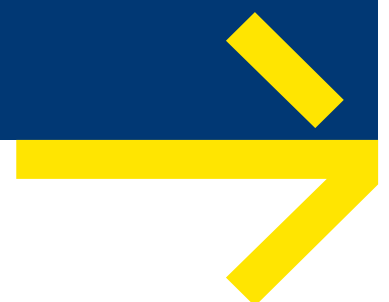

# Standard sliding door systems

## FOR COMFORT AND PERFECTION

Sliding doors are space-saving, elegant and modern. Glass sliding doors are ideal when it comes to making good use of daylight and fulfilling optical criteria. GEZE automatic sliding doors can be used to realise various user scenarios in one building.

### PRODUCT FEATURES

- The variants in the Slimdrive drive series with an overall height of only 7 centimetres blend perfectly into any building's architecture and offer a wide range of application possibilities
- The ECdrive T2 drives are economical and extremely reliable in their functionality
- The products from the Powerdrive series are real power packs and capable of moving heavy doors conveniently and safely

### AREAS OF APPLICATION

- Public buildings and authorities
- Office buildings and car dealerships
- Shopping centres and shop fitting
- Airports and railway stations
- Health and care sector, e.g. hospitals, pharmacies
- Hotels and restaurants
- Banks and education institutes e.g. schools, universities
- Industrial buildings
- Vestibule systems

### STANDARDS

- DIN 18650  
The industrial norm DIN 18650 was created to guarantee operators and users of automatic doors optimum safety. GEZE sliding door systems have been type-tested and certified in accordance with DIN 18650.
- EN 16005  
The new European norm EN 16005 sets out the design requirements and testing methods used to ensure the safe use of automatic doors. This norm has created a Europe-wide safety standard for automatic doors. All automatic door systems and safety sensors from GEZE meet the EN 16005 standard and are available.



Augustinum, Stuttgart, Germany (photo: Dirk Wilhelmy)

### REDUNDANT SLIDING DOORS FOR ESCAPE AND RESCUE ROUTES (FR)

To guarantee the safety of escape and rescue routes, the control unit is designed in a redundant way in connection with the complete system. This redundancy guarantees that in the event of a power failure or fault, the sliding door will automatically open safely in the “Automatic” and “Exit only” modes of operation. In “Night” mode of operation the locking mechanism prevents unauthorised opening of the door. There is no escape and rescue route function in this mode of operation.



Kolbenschmidt Pierburg, Neckarsulm, Germany (photo: Nikolaus Grünwald)

## DESIGN POSSIBILITIES WITH THE SLIDING DOOR SYSTEM



1 = Sliding door drive | 2 = Moving leaf | 3 = Side screen | 4 = Combined detector | 5 = Active infrared detector | 6 = Programme switch with key switch | 7 = Plastic elbow switch | 8 = LED sensor switch glass | 9 = Non-contact proximity switch | 10 = Elbow switch | 11 = LED sensor foot switch



ECdrive T2-FR automatic sliding door drive, Aldi Süd - branch in Mühlendorf (photo: Robert Sprang / GEZE GmbH)

# ECdrive T2



## Automatic linear sliding door system for doors up to 140 kg leaf weight



### AREAS OF APPLICATION

- Single and double leaf sliding door systems
- Interior and exterior doors with high access frequency
- Complete solution for entrance areas with GCprofile Therm and fanlight
- If extra impermeability or energy efficiency are needed
- Opening widths from 700 to 3000 mm possible
- Door leaf weights up to 140 kg per leaf
- Suitable profile systems are fine-framed profile systems with ISO and MONO glass, GCprofile Therm, toughened safety glass clamping profile, on-site framed moving leaf doors and wooden leaves

### PRODUCT FEATURES

- Slim design with a cover height of just 100 mm for greater creative freedom
- With double roller carriage and GCprofile Therm up to 140 kg leaf weight
- Efficient installation thanks to pre-drilled tracks and oblong holes
- Continuous floor guide available for controlled diversion of rainwater
- Integrated cable guides make it easier to lay cables
- Can be networked, and integrated into the building automation via open standard (BACnet)
- Independent error recognition and recording
- Freely configurable inputs and outputs for different functions
- Integrated rechargeable battery for emergency opening and closing in the event of a power failure
- Self-cleaning roller carriage reduces maintenance effort and costs
- Various mechanical and electrical locks are optionally available
- Service interface for simple maintenance

TECHNICAL DATA

	ECdrive T2	ECdrive T2-FR
For 1-leaf door systems	●	●
For 2-leaf door systems	●	●
Height	100 mm	
Depth	190 mm	
Leaf weight (max.) 1-leaf	120 kg*	
Leaf weight (max.) 1-leaf with GCprofile Therm	140 kg*	
Leaf weight (max.) 2-leaf	120 kg*	
Leaf weight (max.) 2-leaf with GCprofile Therm	140 kg*	
Opening width 1-leaf	700 to 3000 mm	
Opening width 1-leaf with GCprofile Therm	700 to 1500 mm	
Opening width 2-leaf	900 to 3000 mm	
Opening width 2-leaf with GCprofile Therm	900 to 3000 mm	
Temperature range	-15 to 50 °C	
IP rating	IP20	
Disconnection from mains	Main switch in the drive	
Opening speed (max.)	0.8 m/s	
Closing speed (max.)	0.8 m/s	
Hold-open time	0 to 60 s	
Adjustable opening and closing force (max.)	150 N	
Automatic adaptation to traffic flow	●	●
Automatic reversal when an obstacle is detected	●	●
Pharmacy opening	●	●
Interlocking door system function	●	-
Vestibule function	●	-
Automatic opening in the event of a power failure	adjustable	standard
Automatic closing in the event of a power failure	adjustable	not available
Function in the event of a power failure	adjustable for 30 min / 30 cycles	open
Automatic opening in the event of a fault	not available	standard
Approvals	DIN 18650 EN 16005 DIN EN ISO 13849: Performance Level D	DIN 18650 EN 16005 DIN EN ISO 13849: Performance Level D AutSchR

● = yes | - = not available | \* = 120 kg with single roller carriage (standard), 140 kg with double roller carriage (option) and GCprofile Therm

DRIVE COMPONENTS

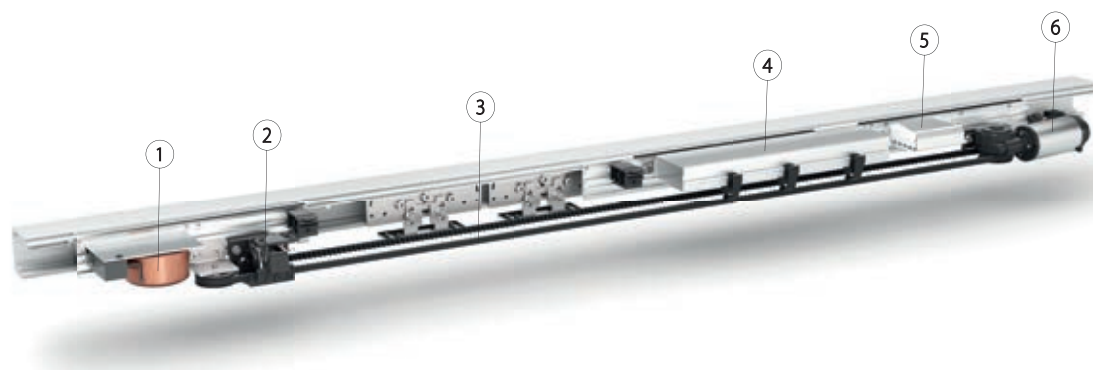

1 = Transformer | 2 = Locking mechanism | 3 = Roller carriage | 4 = Control unit | 5 = Rechargeable battery | 6 = Motor

**TECHNICAL DATA**

	ECdrive T2	ECdrive T2-FR
<b>TRANSFORMER</b>	Ring core with protection and main switch	
Voltage	230 V	
Frequency	50 Hz	
Capacity rating	140 W	
<b>LOCKING MECHANISM</b>	Toothed belt locking, electro-magnetic, bi-stable	
<b>ROLLER CARRIAGE</b>		
Door leaf adjustment vertical	10 mm	
Door leaf adjustment horizontal	15 mm	
Tiling protection	standard	
Self-cleaning	●	●
<b>CONTROL UNIT</b>	DCU1-NT	DCU1-2M-NT
With fault memory	●	●
With memory for statistical data	●	●
Software update possible	●	●
Bus interface optional	●	●
Connection for fire alarm system	●	●
Power supply for peripherals	●	●
Programmable inputs	3 pc.	
Programmable outputs	2 pc.	
<b>RECHARGEABLE BATTERY</b>	NiCd, 24 V, 700 mAh	
<b>MOTOR</b>	Motor gear unit	Double motor gear unit
Torque	400 Ncm	

● = yes

**FITTING VARIANTS**

Door fittings	ECdrive T2
ISO glass fine-framed	●
MONO glass fine-framed	●
GCPprofile Therm, energy-efficient profile system fine-framed	●
Toughened safety glass clamping profile	●
All-glass system (GGS)	-
Integrated all-glass system (IGG)	-
Wooden leaf (on-site)	●

● = yes | - = not available

**CALCULATION OF THE DRIVE LENGTH AL IN MM\***

	ECdrive T2		ECdrive T2-FR**	
	Opening width (ÖW)	Drive length	Opening width (ÖW)	Drive length
2-leaf	900 – 1000	ÖW + 1100	900 – 1070	ÖW + 1170
	1000 – 3000	2 x ÖW + 100	1070 – 3000	2 x ÖW + 100
1-leaf left hand slide to open	700 – 3000	2 x ÖW + 75	700 – 800	ÖW + 880
			800 – 3000	2 x ÖW + 75
1-leaf right hand slide to open	700 – 3000	2 x ÖW + 75	700 – 800	ÖW + 880
			800 – 3000	2 x ÖW + 75

\* = Minimum installation length of the complete system with profile system ISO glass fine-framed | \*\* For FR variants (FR-RWS, FR-LL) request drawing no. 70518-0-001!



**Note:**



Opening widths of escape route sliding doors < 1000 mm are only permitted in exceptional cases. A continuous floor guide is recommended for external systems from an opening width of 2000 mm. The minimum opening widths depend on the requirements of building law.

**CALCULATION OF LEAF AND GLASS DIMENSIONS IN MM**

		ISO glass with aluminium secondary closing edge	ISO glass with rubber secondary closing edge	Toughened safety glass
Leaf width	1-leaf	$\ddot{O}W + 40$	$\ddot{O}W + 35$	$\ddot{O}W + 35$
	2-leaf	$\ddot{O}W / 2 + 40$	$\ddot{O}W / 2 + 35$	$\ddot{O}W / 2 + 35$
Leaf height	1-leaf / 2-leaf	FH = DH		
Glass width	1-leaf / 2-leaf	FB - 41	FB - 36	FB - 26
Glass height		FH - 90	FH - 90	FH - 85
Glass thickness		ISO = 22, MONO = 10		

→ **Note:** max. leaf ratio width to height 1:4

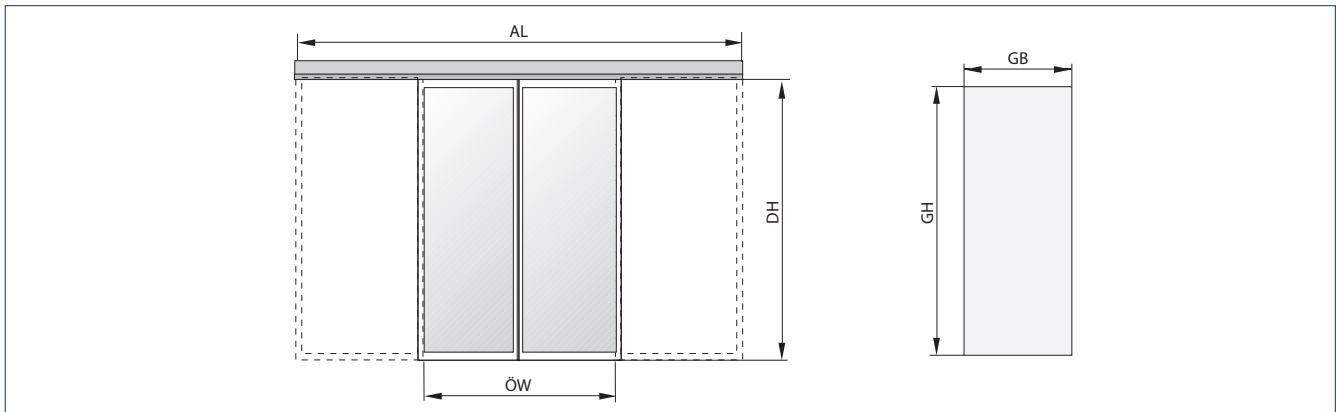

AL = Drive length | DH = Passage height | GB = Glass width | GH = Glass height | ÖW = Opening width

**WITH ISO/MONO GLASS FITTING – WITHOUT SIDE SCREEN**

Drawing no. 70518-ep01 / 70518-ep02

Wall installation, angled floor guide, ISO glass

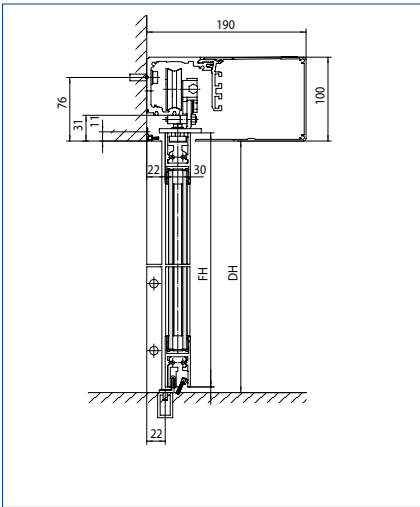

Wall installation, angled floor guide, ISO glass

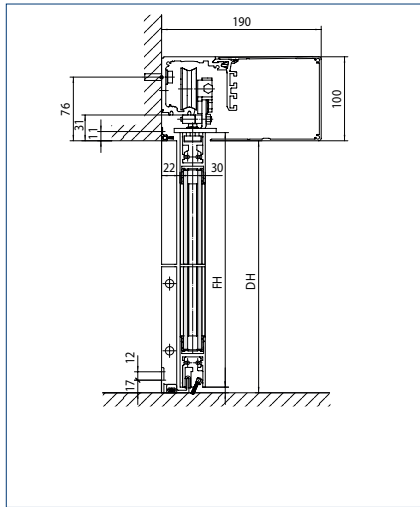

Wall installation, continuous floor guide, MONO glass

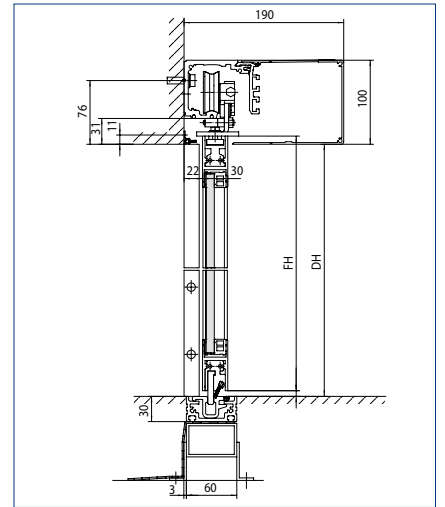

1-leaf, wall installation, ALU secondary closing edge, angled floor guide, left hand slide to open, MONO glass

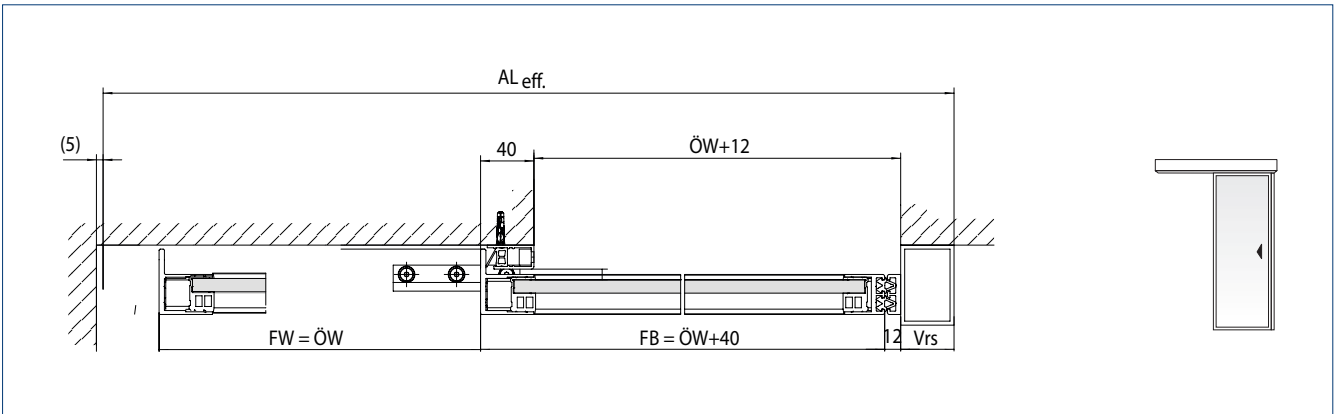

2-leaf, wall installation, rubber secondary closing edge, angled floor guide / adjustable floor guide, with protective leaf, ISO and MONO glass

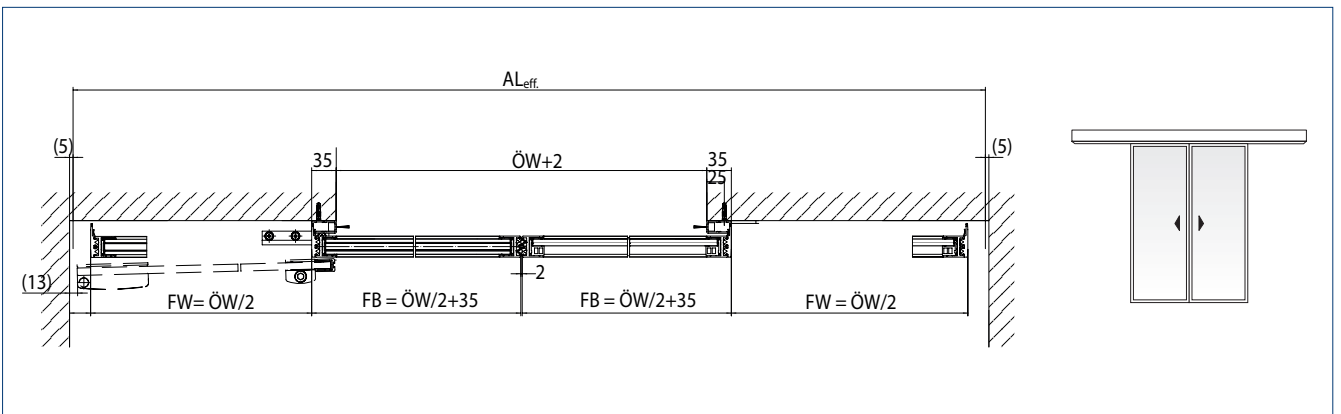

DH = Passage height | FH = Left height | FW = Travel path | FB = Leaf width | ÖW = Opening width | Vrs = Drive extension right | AL eff. = Effective drive length

WITH ISO/MONO GLASS FITTING - WITH SIDE SCREEN - MOUNTING WITHIN REVEAL

Drawing no. 70518-ep10

Mounting within reveal (thin), adjustable floor guide, ISO glass

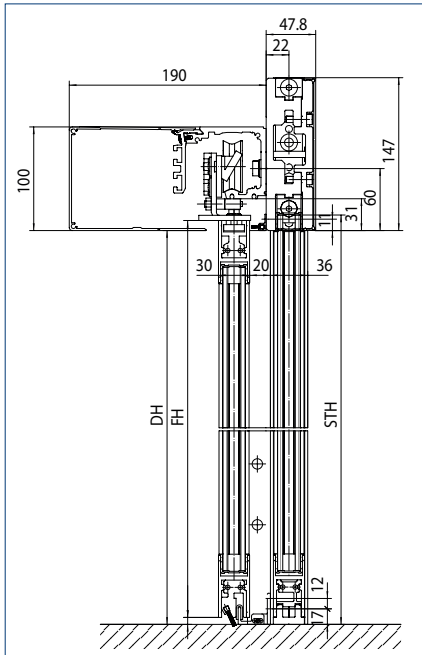

Mounting within reveal, aluminium secondary closing edge, continuous floor guide, ISO and MONO glass

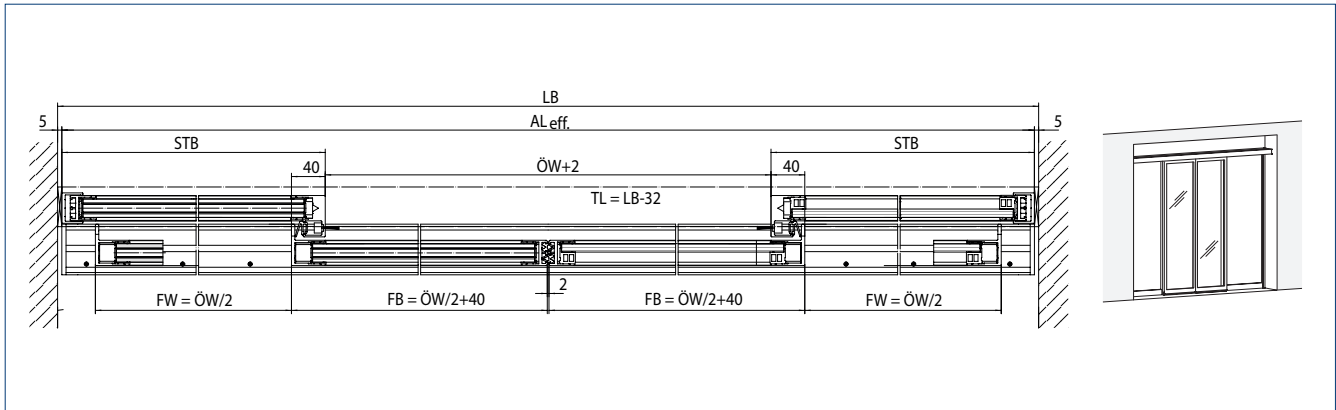

Mounting within reveal, rubber secondary closing edge, angled / adjustable floor guide, with protective leaf, ISO and MONO glass

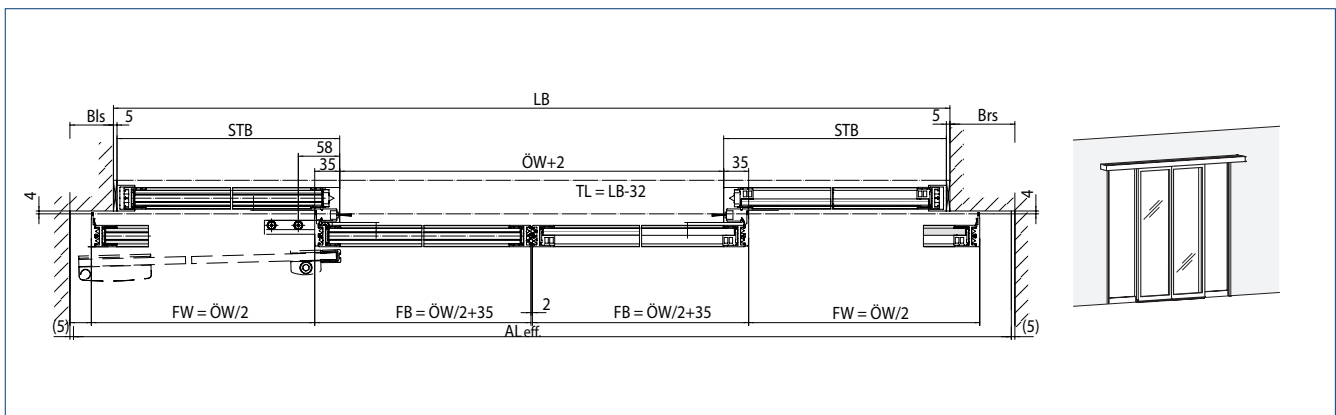

LB = Cear installation width | STB = Side screen width | STH = Side screen height | FH = Leaf height | FB = Leaf width | FW = Travel path | ÖW = Opening width | DH = Passage height | TL = Lintel length | Bls = Fastening left | Brs = Fastening right | AL eff. = Effective drive length

**WITH ISO/MONO GLASS FITTING – WITH SIDE SCREEN – WALL MOUNTING**

Drawing no. 70518-ep14

Wall mounting, adjustable floor guide

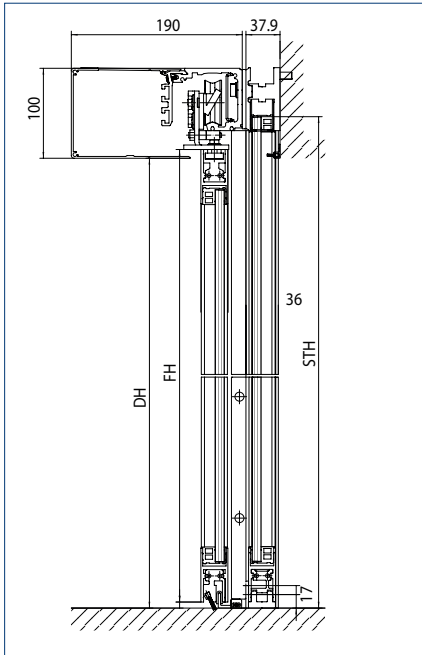

2-leaf, wall mounting, rubber secondary closing edge, angled floor guide / adjustable floor guide, with protective leaf

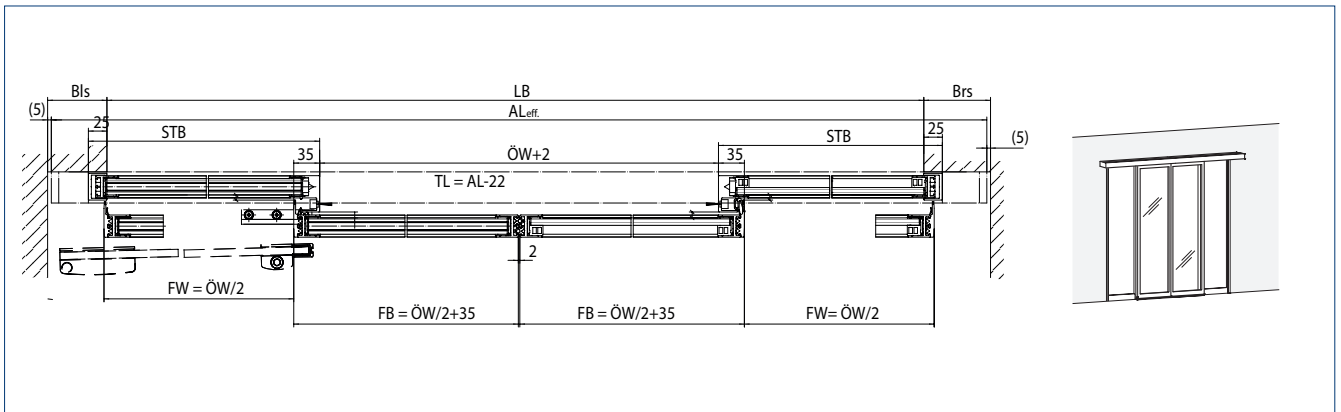

LB = Cear installation width | STB = Side screen width | STH = Side screen height | FH = Leaf height | FB = Leaf width | FW = Travel path | ÖW = Opening width | DH = Passage height | Bls = Fastening left | Brs = Fastening right | ALeff. = Effective drive length

WITH TOUGHENED SAFETY GLASS CLAMPING FITTING – WITHOUT SIDE SCREEN

Drawing no. 70518-ep03 / 70518-ep04

Wall installation, adjustable floor guide

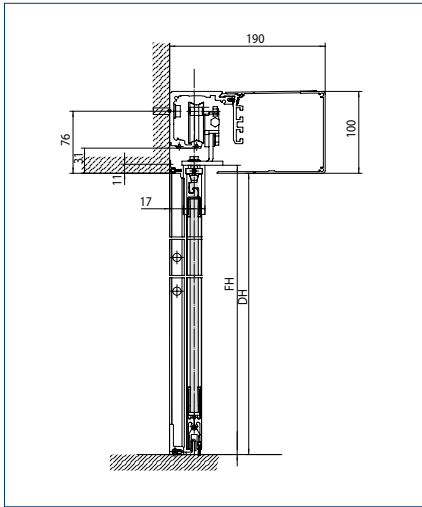

1-leaf, wall installation, plastic secondary closing edge, adjustable angled floor guide, left hand slide to open

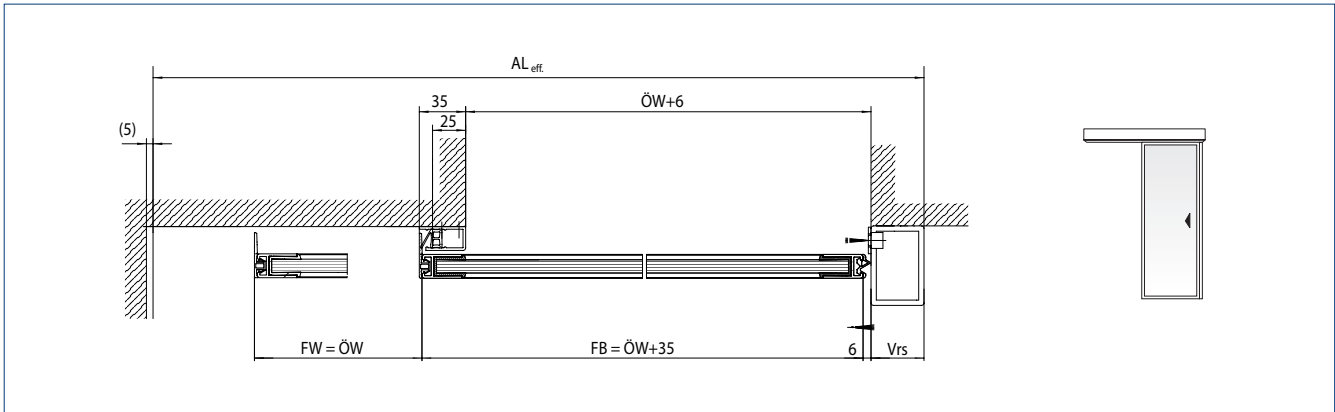

2-leaf, wall installation, rubber secondary closing edge, adjustable floor guide with protective leaf

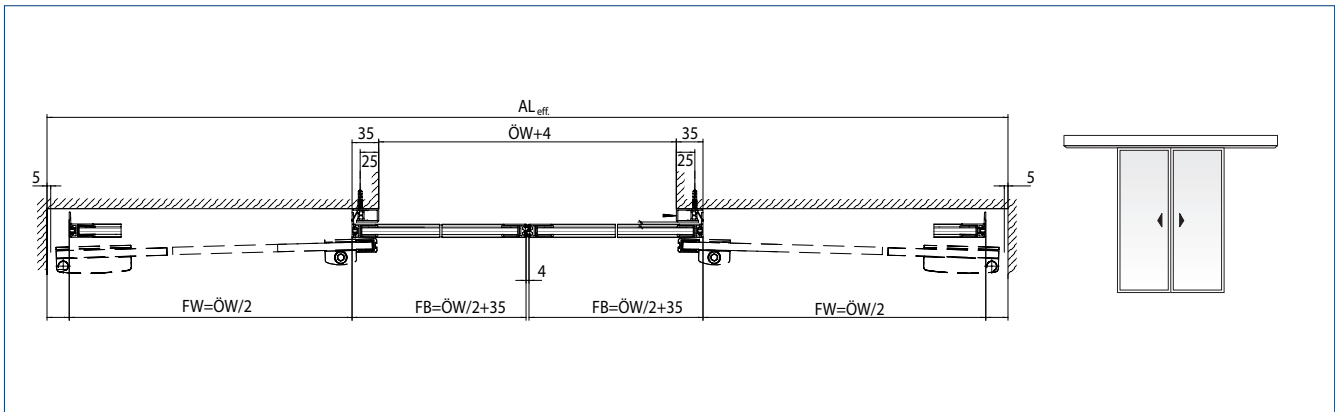

FW = Travel path | FB = Leaf width | ÖW = Opening width | Vrs = Drive extension right | DH = Passage height | FH = Leaf height | AL\_eff = Effective drive extension

**WITH TOUGHENED SAFETY GLASS CLAMPING FITTING – WITH SIDE SCREEN**

Drawing no. 70504-ep12

Mounting within reveal (thin), adjustable floor guide

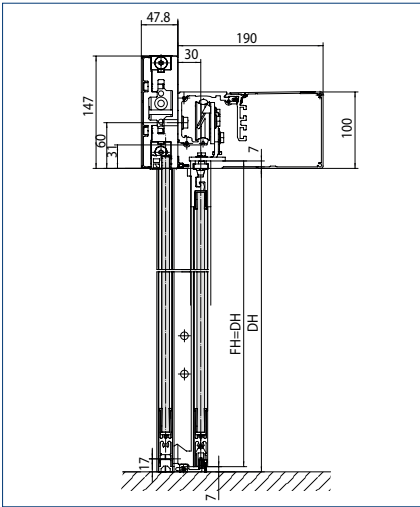

2-leaf, mounting within reveal, angled floor guide, protective leaf

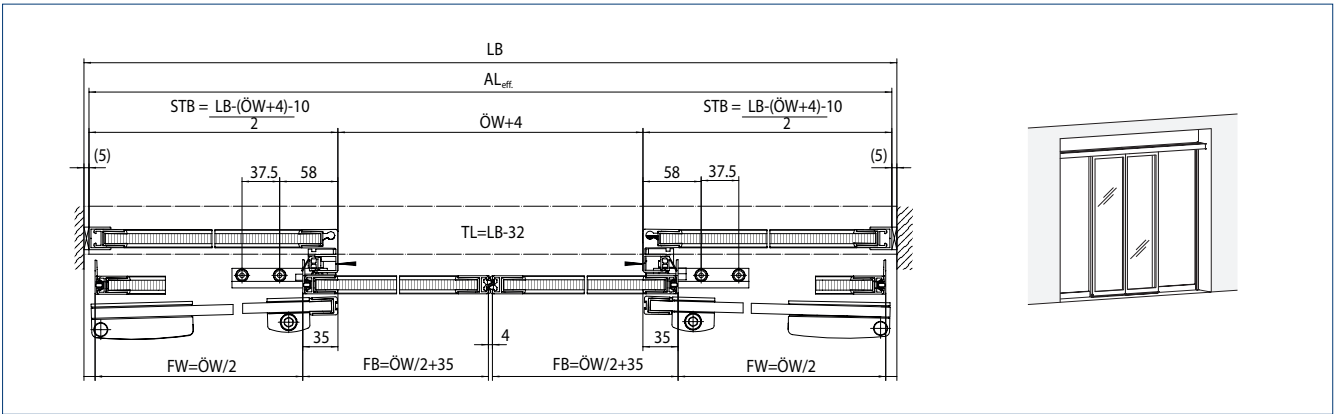

2-leaf, mounting within reveal, adjustable floor guide

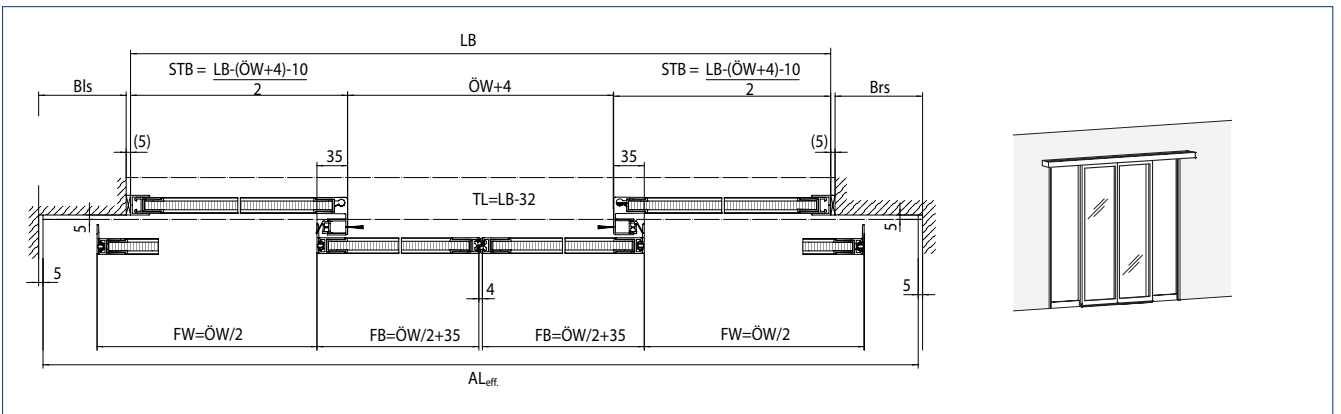

LB = Clear installation width | STB = Side screen width | FH = Leaf height | FB = Leaf width | FW = Travel path | ÖW = Opening width | DH = Passage height | TL = Lintel length | Bls = Fastening left | Brs = Fastening right | AL\_eff = Effective drive length

**WITH GCPROFILE THERM, ENERGY-EFFICIENT PROFILE SYSTEM FINE-FRAMED – WITHOUT SIDE SCREEN**

Drawing no. 70518-ep100 / 70518-ep110

Wall installation, continuous floor guide

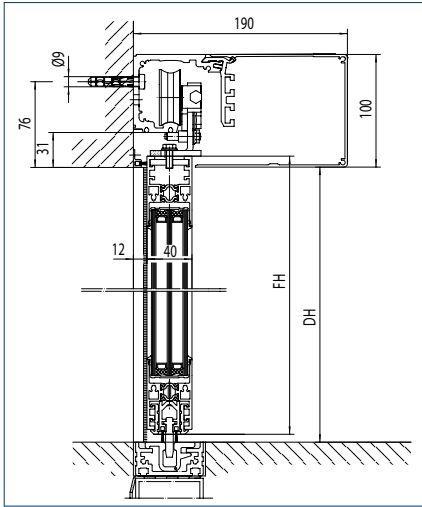

Wall installation, angled floor guide

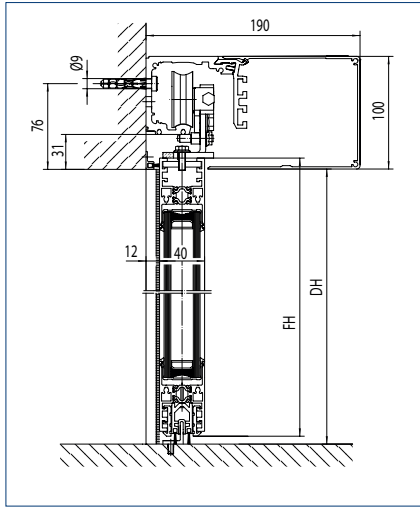

1-leaf, wall installation

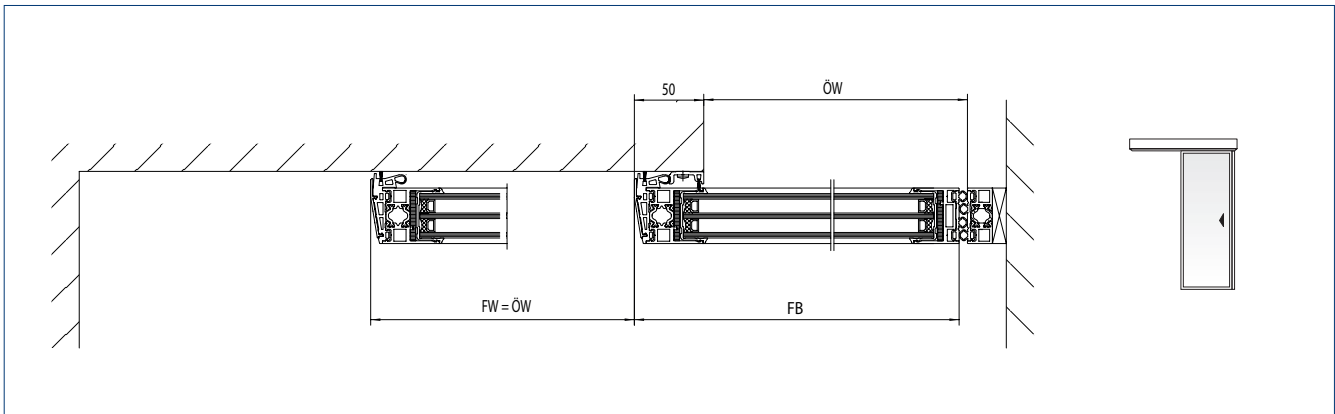

2-leaf, wall installation

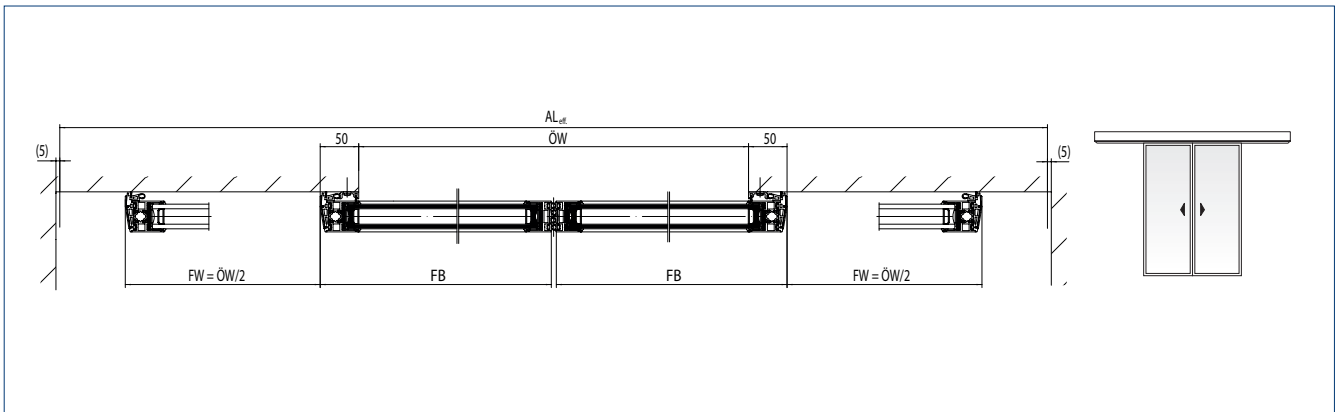

FH = Leaf height | FB = Leaf width | FW = Travel path | ÖW = Opening width | DH = Passage height | AL<sub>eff</sub> = Effective drive length

**WITH GCPROFILE THERM, ENERGY-EFFICIENT PROFILE SYSTEM FINE-FRAMED – WITH SIDE SCREEN BELOW LINTEL**

Drawing no. 70518-ep103

Vertical section side screen

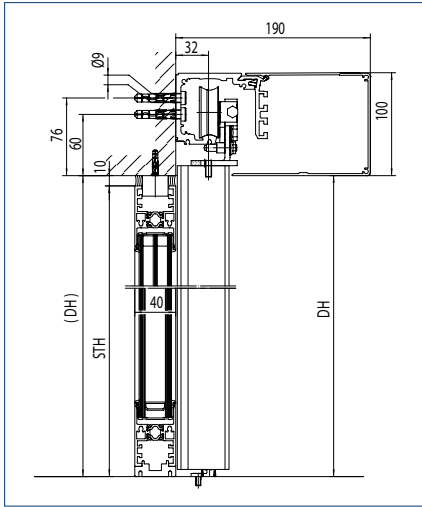

Vertical section moving leaf

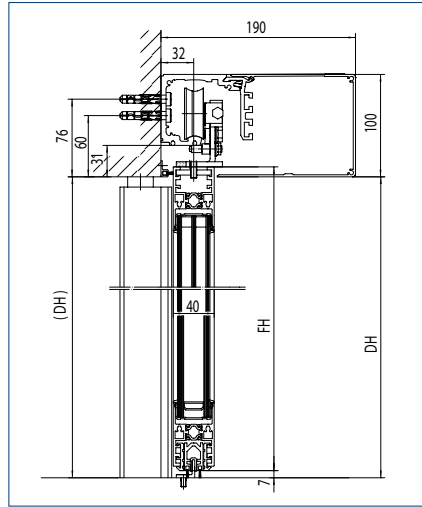

Drive length corresponding to or smaller than clear installation width

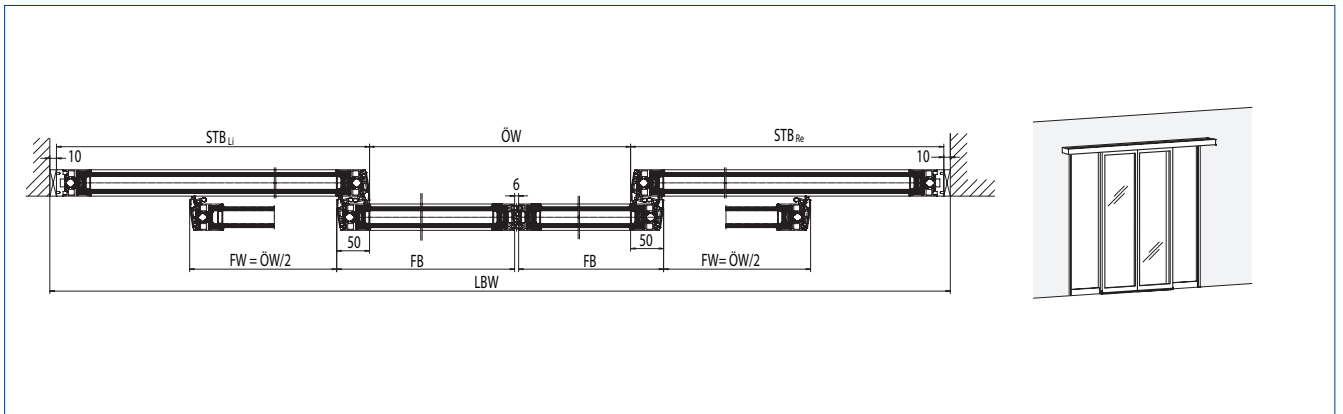

Drive length greater than clear installation width

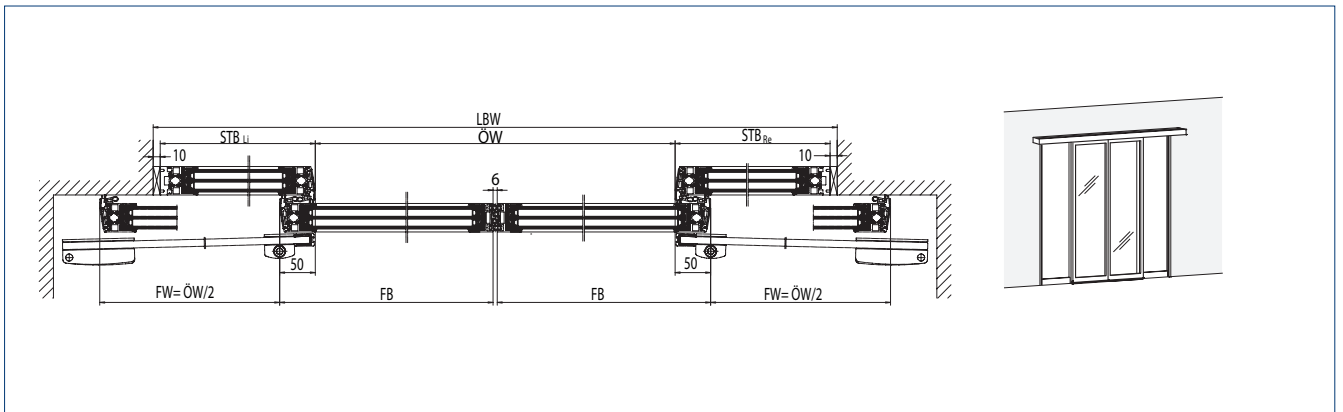

LBW = Clear installation width | STB<sub>Li</sub> = Side screen width left | STB<sub>Re</sub> = Side screen width right | FW = Travel path | FB = Leaf width | ÖW = Opening width | DH = Passage height

**WITH ISO/MONO GLASS FITTING – WITH SIDE SCREEN – PARTITION WALL INSTALLATION**

Drawing no. 70518-ep101

Vertical section moving leaf, continuous floor guide

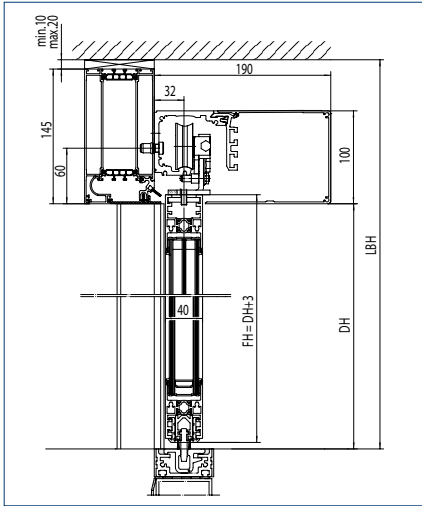

Vertical section side screen, angled floor guide

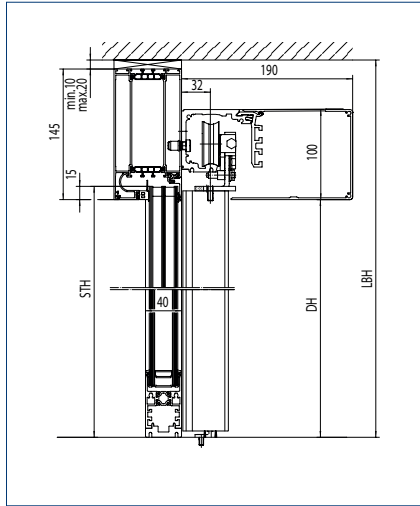

2-leaf , horizontal section

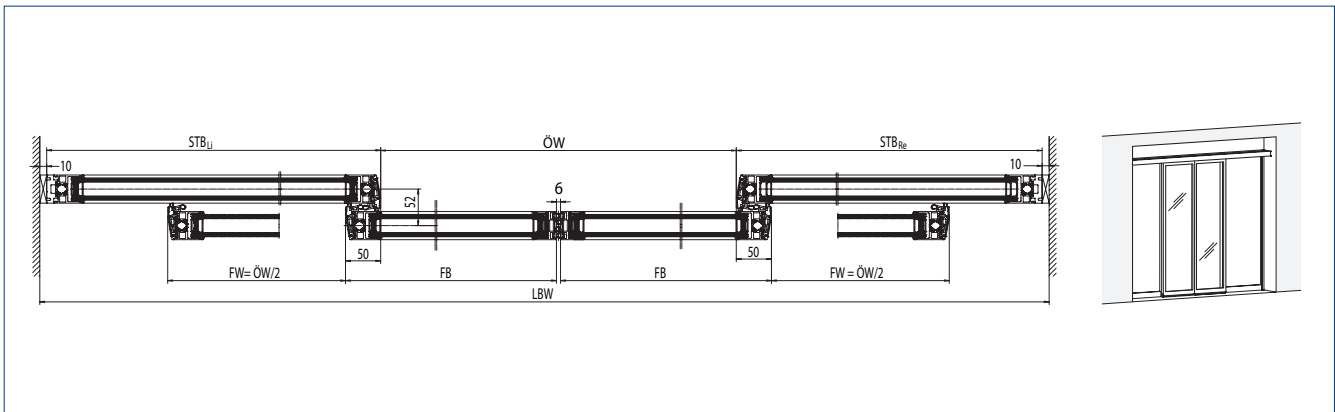

LBW = Clear installation width | LBH = Clear installation height | STH = Side screen height | STB<sub>Li</sub> = Side screen width left | STB<sub>Re</sub> = Side screen width right | FW = Travel path | FB = Leaf width | FH = Leaf height | OW = Opening width | DH = Passage height

**WITH GCPROFILE THERM ENERGY-EFFICIENT PROFILE SYSTEM –  
WITH SIDE SCREEN AND FANLIGHT**

Drawing no. 70518-ep102

Vertical section moving leaf

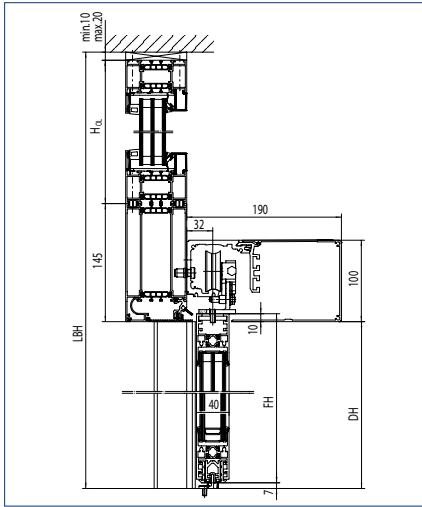

Vertical section side screen

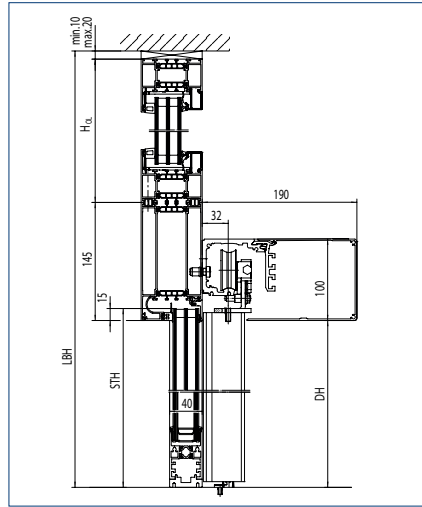

Horizontal section

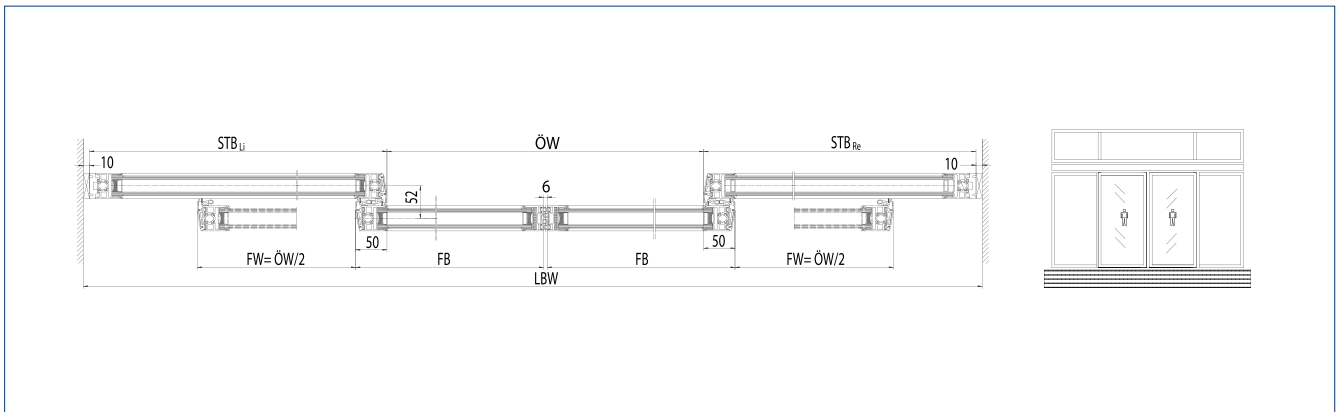

HOL = High fanlight | LBW = Clear installation width | LBH = Clear installation height | STH = Side screen height | STB Li = side screen width left | STB Re = side screen width right | FW = Travel path | FB = Leaf width | FH = Leaf height | ÖW = Opening width | DH = Passage height

# Slimdrive SL NT



Automatic linear sliding door system with low overall height  
and clear design line

## AREAS OF APPLICATION

- Single and double leaf sliding door systems
- Interior and exterior doors with high access frequency
- Façades with slim mullion-transom constructions
- Glass façades with maximum design demands
- Opening widths from 700 to 3000 mm possible
- Door leaf weights up to 125 kg per leaf
- Suitable profile systems are fine-framed profile systems with ISO and MONO glass, all-glass systems (GGS), integrated all-glass systems (IGG) and on-site framed moving leaf doors and wooden leaves

## PRODUCT FEATURES

- Very quiet-running, low-wear direct current drive with height of only 7 cm
- Can be networked, and integrated into the building automation via open standard (BACnet)
- Independent error recognition and recording
- Freely configurable inputs and outputs for different functions
- Integrated rechargeable battery for emergency opening in the event of safety-relevant faults such as a power failure
- Self-cleaning roller carriage reduces maintenance effort and costs
- Various mechanical and electrical locks are optionally available

## TECHNICAL DATA

	SL NT	SL NT-FR
For 1-leaf door systems	●	●
For 2-leaf door systems	●	●
Height	70 mm	
Depth	190 mm	
Leaf weight (max.) 1-leaf	125 kg	
Leaf weight (max.) 2-leaf	125 kg	
Opening width 1-leaf	700 – 3000 mm	
Opening width 2-leaf	900 – 3000 mm	
Temperature range	-15 to 50 °C	
IP rating	IP20	
Disconnection from mains	Main switch in the drive	
Opening speed (max.)	0.8 m/s	
Closing speed (max.)	0.8 m/s	
Hold-open time	0 to 60 s	
Adjustable opening and closing force (max.)	150 N	
Automatic adaptation to traffic flow	●	●
Automatic reversal when an obstacle is detected	●	●
Pharmacy opening	●	●
Interlocking door system function	●	-
Vestibule function	●	-
Automatic opening in the event of a power failure	adjustable	standard
Automatic closing in the event of a power failure	adjustable	not available
Function in the event of a power failure	adjustable for 30 min / 30 cycles	open
Automatic opening in the event of a fault	not available	standard
Approvals	DIN 18650, EN 16005, DIN EN ISO 13849: Performance Level D	DIN 18650, EN 16005, DIN EN ISO 13849: Performance Level D, AutSchR

● = yes | - = not available

## DRIVE COMPONENTS

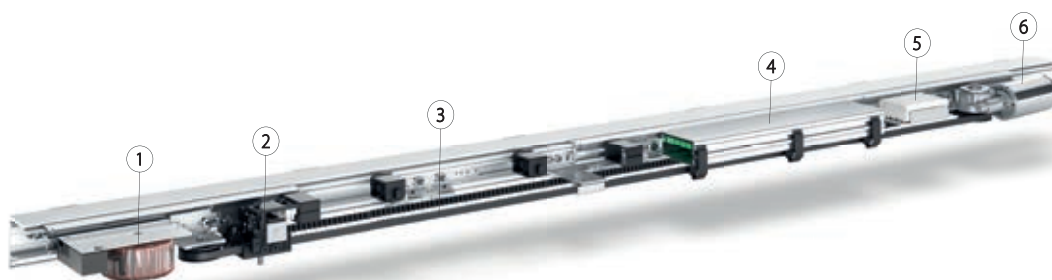

1 = Transformer | 2 = Locking mechanism | 3 = Roller carriage | 4 = Control unit | 5 = Rechargeable battery | 6 = Motor

**TECHNICAL DATA**

	SL NT	SL NT-FR
<b>TRANSFORMER</b>	Ring core with protection and main switch	
Voltage	230 V	
Frequency	50 Hz	
Capacity rating	140 W	
<b>LOCKING MECHANISM</b>	Toothed belt locking, electro-magnetic, bi-stable	
<b>ROLLER CARRIAGE</b>		
Door leaf adjustment vertical	10 mm	
Door leaf adjustment horizontal	6 mm	
Tiling protection	standard	
Self-cleaning	●	●
<b>CONTROL UNIT</b>	DCU1-NT	DCU1-2M-NT
With fault memory	●	●
With memory for statistical data	●	●
Software update possible	●	●
Bus interface optional	●	●
Connection for fire alarm system	●	●
Power supply for peripherals	●	●
Programmable inputs	3 pc.	
Programmable outputs	2 pc.	
<b>RECHARGEABLE BATTERY</b>	NiCd, 24 V, 700 mAh	
<b>MOTOR</b>	Motor gear unit	Double motor gear unit
Torque	400 Ncm	

● = yes

**FITTING VARIANTS**

Door fittings	SL NT
ISO glass fine-framed	●
MONO glass fine-framed	●
GCprofile Therm, energy-efficient profile system fine-framed	-
Toughened safety glass clamping profile	-
All-glass system (GGS)	●
Integrated all-glass system (IGG)	●
Wooden leaf (on-site)	●

● = yes | - = not available

## CALCULATION OF THE DRIVE LENGTH AL IN MM\*

	Slimdrive SL NT		Slimdrive SL NT-FR**	
	Opening width (ÖW)	Drive length	Opening width (ÖW)	Drive length
2-leaf	900 – 1000	$\ddot{O}W + 1100$	900 – 1070	$\ddot{O}W + 1170$
	1000 – 3000	$2 \times \ddot{O}W + 100$	1070 – 3000	$2 \times \ddot{O}W + 100$
1-leaf left hand slide to open	700 – 3000	$2 \times \ddot{O}W + 60$	700 – 800	$\ddot{O}W + 860$
			800 – 3000	$2 \times \ddot{O}W + 60$
1-leaf right hand slide to open	700 – 3000	$2 \times \ddot{O}W + 60$	700 – 800	$\ddot{O}W + 860$
			800 – 3000	$2 \times \ddot{O}W + 60$

When using Lock A, the drive length increases by 100 mm. | When using Lock M at 1-leaf doors, the drive length increases by 100 mm. For Lock M on 2-leaf doors, the drive only extends by 100 mm if an optional bolt message is installed | \* Minimum installation length of the complete system with profile system ISO glass fine-framed | \*\* For FR variants (FR-RWS, FR-LL) request drawing!



### Note:



Opening widths of escape route sliding doors < 1000 mm are only permitted in exceptional cases. A continuous floor guide is recommended for external systems from an opening width of 2000 mm. The minimum opening widths depend on the requirements of building law.

## CALCULATION OF LEAF AND GLASS DIMENSIONS IN MM (ISO GLASS PROFILE SYSTEM)

ISO glass		
Leaf width	1-leaf	$\ddot{O}W + 35$
	2-leaf	$\ddot{O}W / 2 + 35$
Leaf height	1-leaf / 2-leaf	$FH = DH - 2$
Glass width	1-leaf	$\ddot{O}W$
	2-leaf	$\ddot{O}W / 2$
Glass height	1-leaf / 2-leaf	$FH - 90$
Glass thickness		22

→ **Note:** max. leaf ratio width to height 1:4

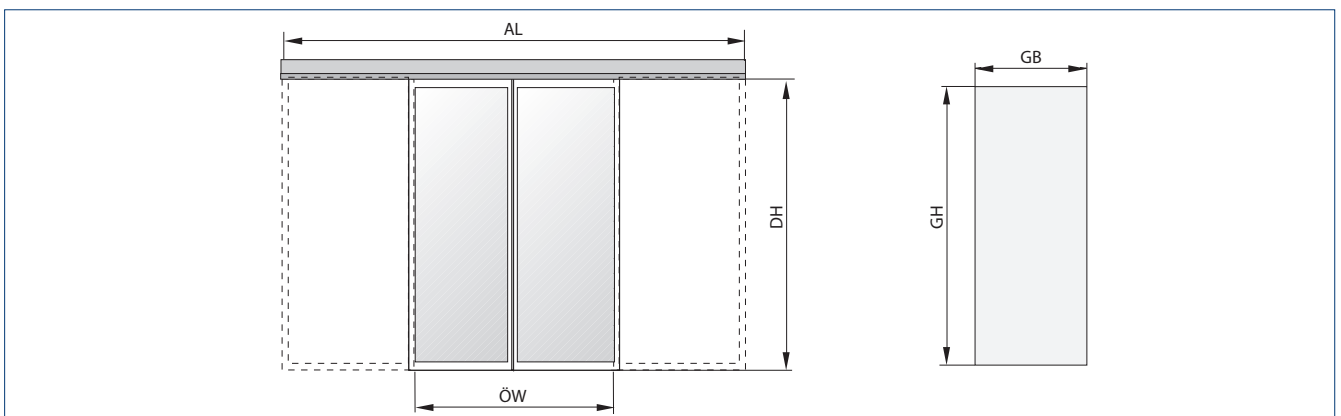

AL = Drive length | DH = Passage height | GB = Glass width | GH = Glass height | ÖW = Opening width

WITH ISO/MONO GLASS FITTING – WITHOUT SIDE SCREEN

Drawing no. 70511-ep01

Floor guide: For floor mounting

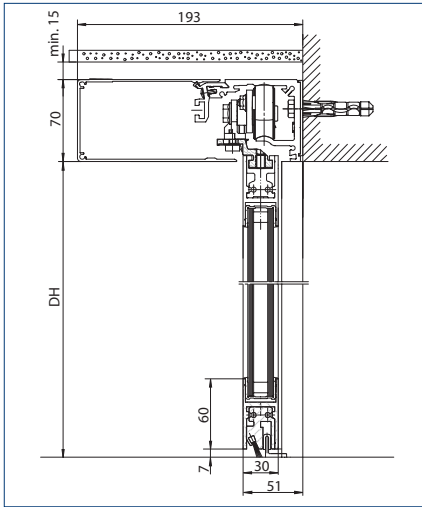

Floor guide: Adjustable for wall installation

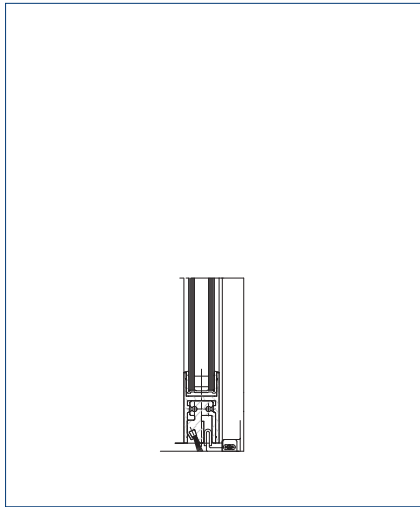

Floor guide: Continuous

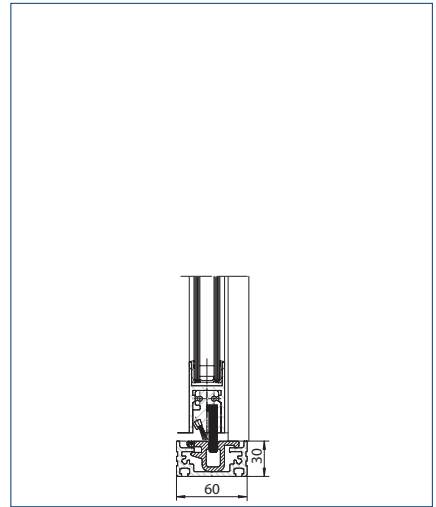

1-leaf door system

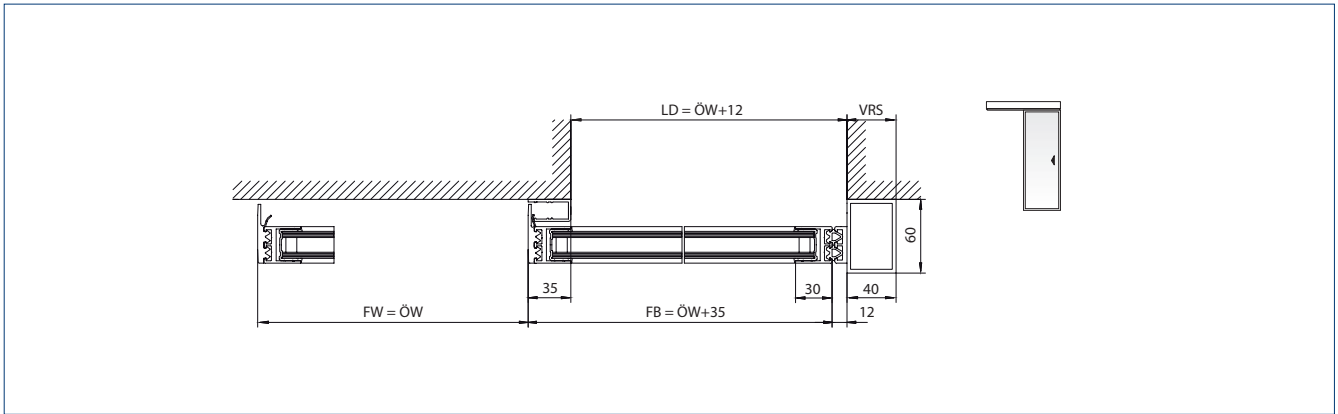

2-leaf door system

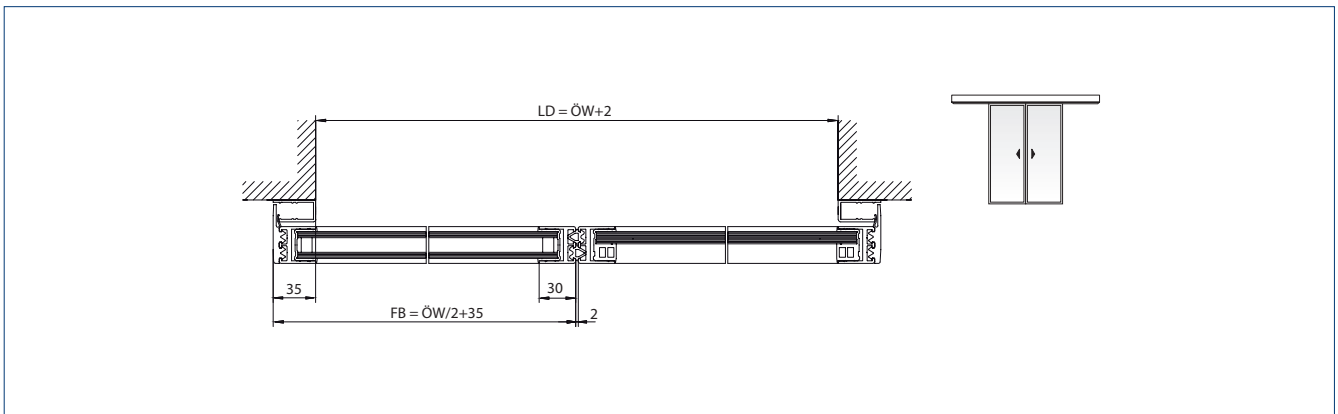

LD = Clear passage | FW = Travel path | FB = Leaf width | ÖW = Opening width | VRS = Drive extension right | DH = Passage height

**WITH ISO/MONO GLASS FITTING – WITH SIDE SCREEN**

Drawing no. 70511-ep02 + 70511-ep04

Low girder section

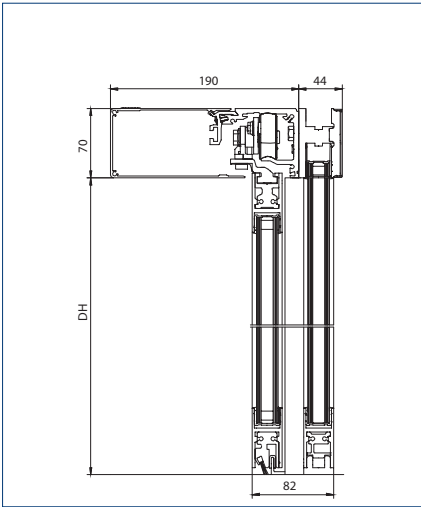

High girder section

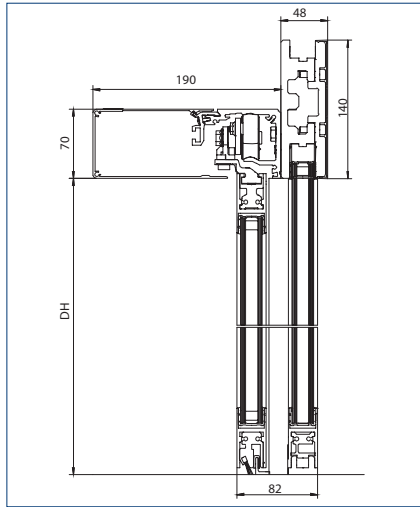

→ **Note:** See installation drawing for area of application

Installation: Self-supporting installation

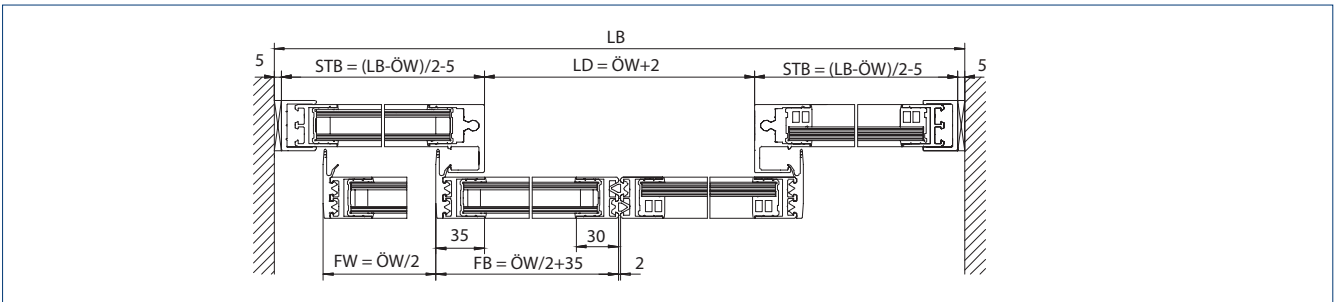

Installation: Wall installation with longer drive and girder section between the walls

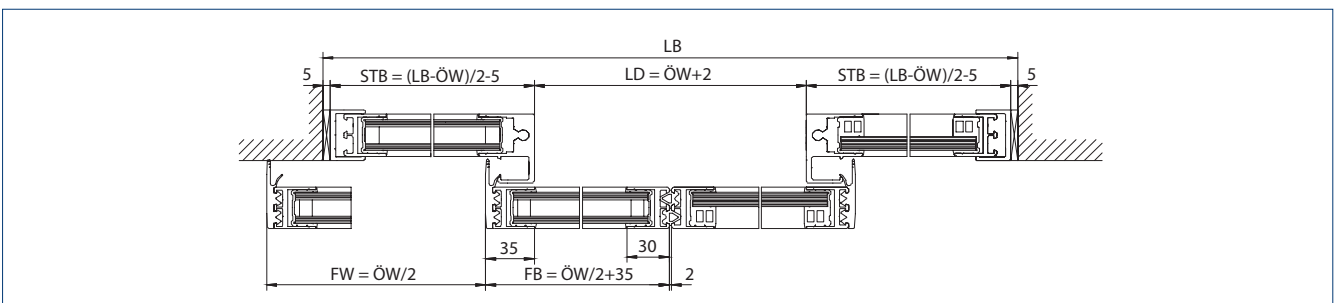

Installation: Wall installation

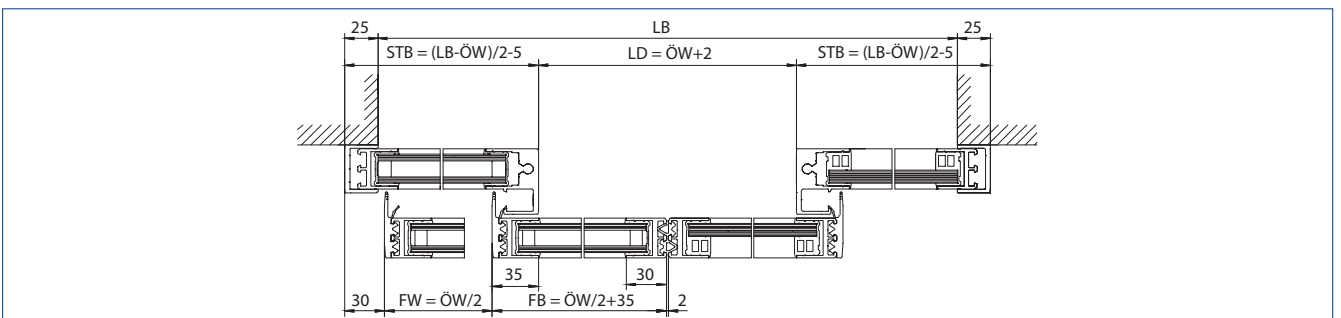

LB = Clear installation width | STB Side screen width | LD = Clear passage | FW = Travel path | FB = Leaf width | ÖW = Opening width | DH = Passage height

# Powerdrive PL



## Automatic linear sliding door system for large and heavy doors up to 200 kg leaf weight

### AREAS OF APPLICATION

- Single and double leaf sliding door systems
- Interior and exterior doors with high access frequency
- Opening widths from 700 to 3000 mm possible
- Door leaf weights up to 200 kg per leaf
- Suitable profile systems are fine-framed profile systems with ISO and MONO glass, toughened safety glass clamping profiles, on-site frames and wooden leaves
- Suitable for various profile systems

### PRODUCT FEATURES

- Very powerful drive for large heavy door leaves and wide opening widths
- Can be networked, and integrated into the building automation via open standard (BACnet)
- Independent error recognition and recording
- Adjustment options for all door motion parameters
- Freely configurable inputs and outputs for different functions
- Integrated rechargeable battery for emergency opening and closing in the event of a power failure
- Various mechanical and electrical locks are optionally available

## TECHNICAL DATA

	PL	PL-FR
For 1-leaf door systems	●	●
For 2-leaf door systems	●	●
Height	150 / 200 mm	
Depth	185 mm	
Leaf weight (max.) 1-leaf	200 kg	160 kg
Leaf weight (max.) 2-leaf	200 kg	160 kg
Opening width 1-leaf	700 to 3000 mm	
Opening width 2-leaf	800 to 3000 mm	
Temperature range	-15 to 50 °C	
IP rating	IP20	
Disconnection from mains	Main switch in the drive	
Opening speed (max.)	0.8 m/s	
Closing speed (max.)	0.8 m/s	
Hold-open time	0 to 60 s	
Adjustable opening and closing force (max.)	150 N	
Automatic adaptation to traffic flow	●	●
Automatic reversal when an obstacle is detected	●	●
Pharmacy opening	●	●
Interlocking door system function	●	-
Vestibule function	●	-
Automatic opening in the event of a power failure	adjustable	standard
Automatic closing in the event of a power failure	adjustable	not available
Function in the event of a power failure	adjustable for 30 min / 30 cycles	open
Automatic opening in the event of a fault	not available	standard
Approvals	DIN 18650 EN 16005 DIN EN ISO 13849: Performance Level D	DIN 18650 EN 16005 DIN EN ISO 13849: Performance Level D AutSchR

● = yes | - = not available

## DRIVE COMPONENTS

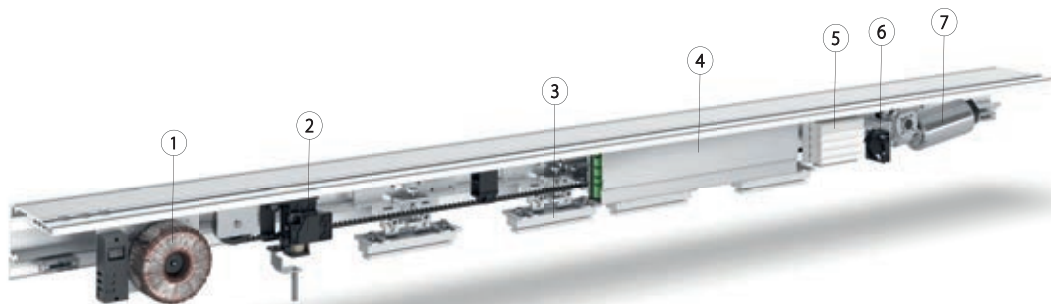

1 = Transformer | 2 = Locking mechanism | 3 = Roller carriage | 4 = Control unit | 5 = Rechargeable battery | 6 = Fan | 7 = Motor

**TECHNICAL DATA**

	PL	PL-FR
<b>TRANSFORMER</b>	Ring core with protection and main switch	
Voltage	230 V	
Frequency	50 Hz	
Capacity rating	200 W	
<b>LOCKING MECHANISM</b>	Toothed belt locking, electro-magnetic, bi-stable	
<b>ROLLER CARRIAGE</b>		
Door leaf adjustment vertical	12 mm	
Door leaf adjustment horizontal	40 mm	
Tiling protection	standard	
Self-cleaning	●	●
<b>CONTROL UNIT</b>	DCU1-NT	DCU1-2M-NT
With fault memory	●	●
With memory for statistical data	●	●
Software update possible	●	●
Bus interface optional	●	●
Connection for fire alarm system	●	●
Power supply for peripherals	●	●
Programmable inputs	3 pc.	
Programmable outputs	2 pc.	
<b>RECHARGEABLE BATTERY</b>	NiCd, 24 V, 700 mAh	
<b>MOTOR</b>	Motor gear unit	Double motor gear unit
Torque	400 Ncm	

● = yes

**FITTING VARIANTS**

Door fittings	PL
ISO glass fine-framed	●
MONO glass fine-framed	●
GCprofile Therm, energy-efficient profile system fine-framed	-
Toughened safety glass clamping profile	●
All-glass system (GGS)	-
Integrated all-glass system (IGG)	-
Wooden leaf (on-site)	●

● = yes | - = not available

**CALCULATION OF THE DRIVE LENGTH AL IN MM\***

Powerdrive	PL		PL-FR**	
	Opening width (ÖW)	Drive length (AL)	Opening width (ÖW)	Drive length (AL)
2-leaf	800 – 3000	$2 \times \ddot{O}W + 100$	800 – 3000	$2 \times \ddot{O}W + 100$
1-leaf	700 – 3000	$2 \times \ddot{O}W + 65$	700 – 3000	$2 \times \ddot{O}W + 65$

\* = Minimum installation length of the complete system with profile system ISO glass fine-framed | \*\* For FR variants (FR-RWS, FR-LL) request drawing!



**Note:**



Opening widths of escape route sliding doors < 1000 mm are only permitted in exceptional cases. A continuous floor guide is recommended for external systems from an opening width of 2000 mm. The minimum opening widths depend on the requirements of building law.

**CALCULATION OF LEAF AND GLASS DIMENSIONS IN MM**

		ISO glass with aluminium secondary closing edge	ISO glass with rubber secondary closing edge	Toughened safety glass
Leaf width	1-leaf	$\ddot{O}W + 40$	$\ddot{O}W + 35$	$\ddot{O}W + 35$
	2-leaf	$\ddot{O}W / 2 + 40$	$\ddot{O}W / 2 + 35$	$\ddot{O}W / 2 + 35$
Leaf height	with cover 150 mm	DH		
	for cover 200 mm	DH + 50		
Glass width	1-leaf	$\ddot{O}W$	$\ddot{O}W$	$\ddot{O}W + 9$
	2-leaf	$\ddot{O}W / 2$	$\ddot{O}W / 2$	$\ddot{O}W / 2 + 9$
Glass height		FH – 90	FH – 90	FH – 85
Glass thickness		22	22	10, 12

→ **Note:** max. leaf ratio width to height 1:4

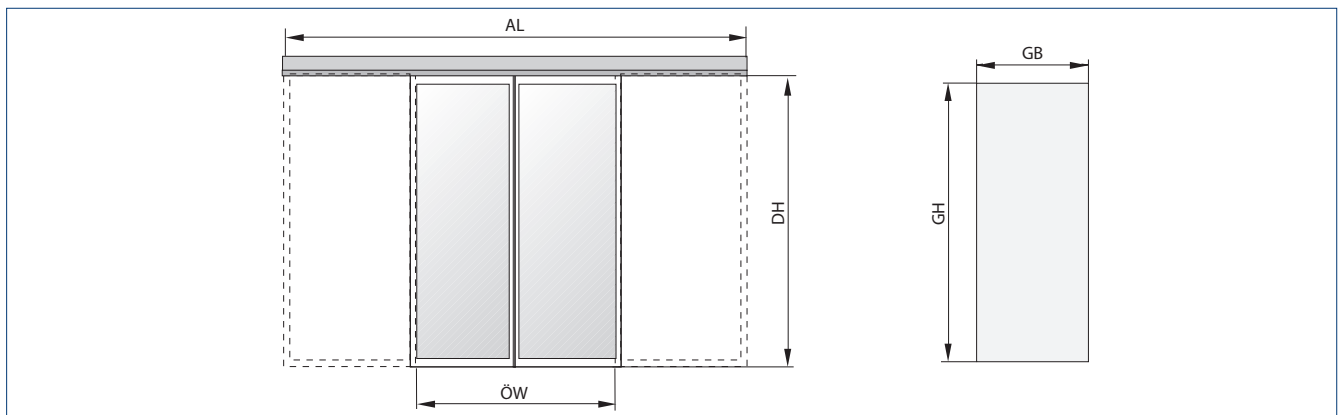

AL = Drive length | DH = Passage height | GB = Glass width | GH = Glass height | ÖW = Opening width

WITH ISO/MONO GLASS FITTING – WITHOUT SIDE SCREEN

Drawing no. 70506–ep01

Floor guide: For floor mounting

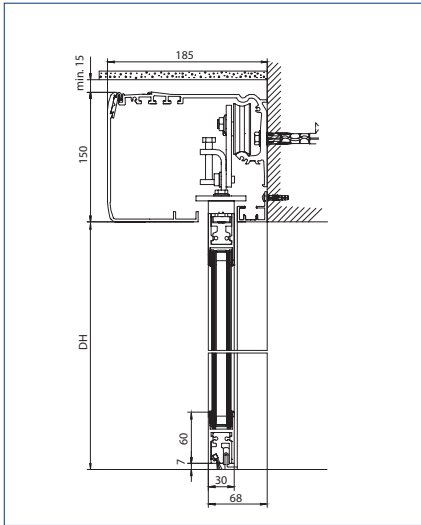

Floor guide: Adjustable for wall installation



Floor guide: Continuous

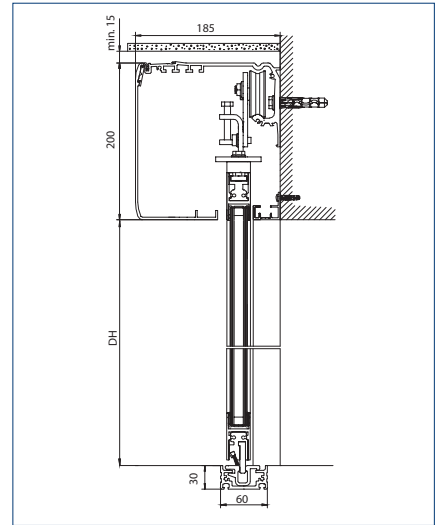

1-leaf door system

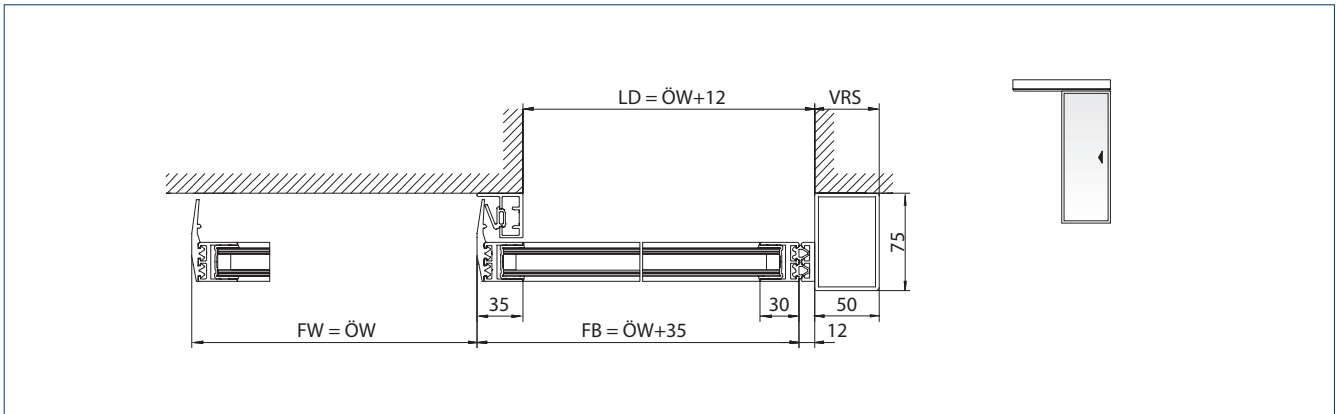

2-leaf door system

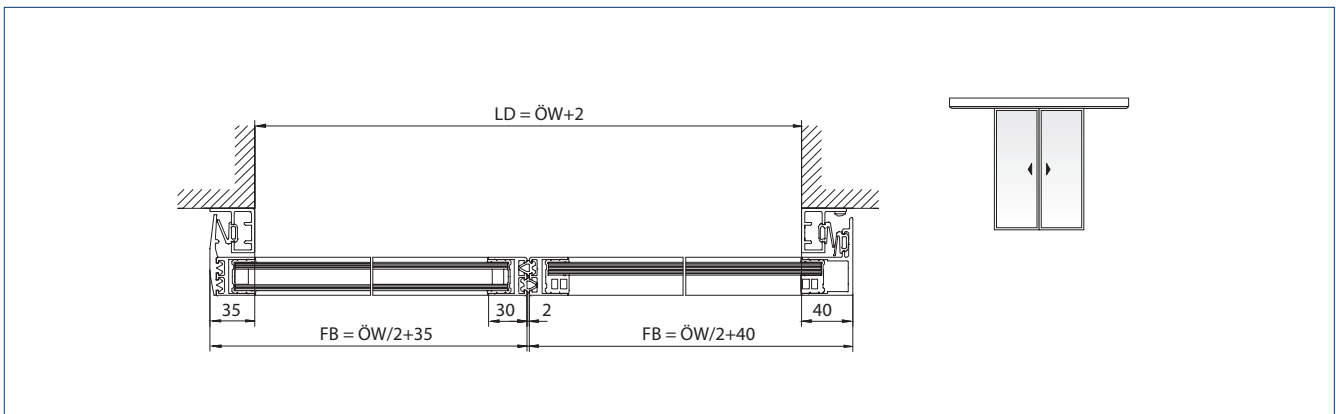

LD = Clear passage | FW = Travel path | FB = Leaf width | ÖW = Opening width | VRS = Drive extension right | DH = Passage height

WITH ISO/MONO GLASS FITTING – WITH SIDE SCREEN

Drawing no. 70506-ep02

Door system with door leaf and side screens under drive

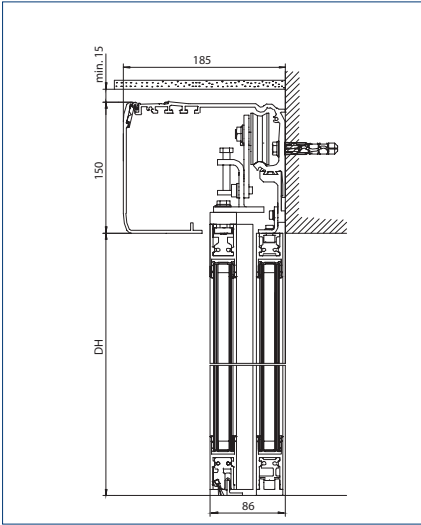

Door system with door leaf and side screens under drive

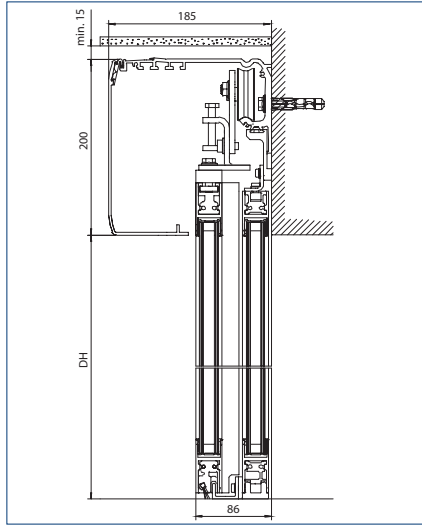

Door system with door leaf and side screens under girder section

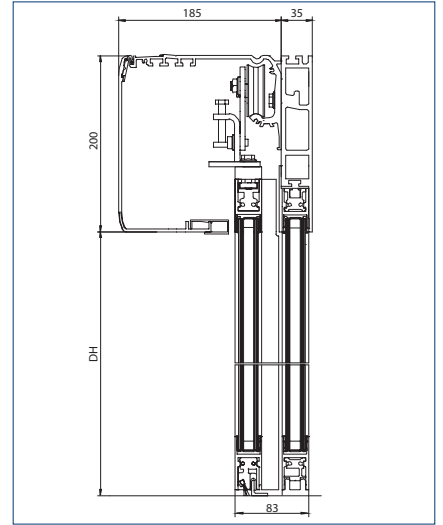

→ **Note:** See installation drawing for area of application

Installation: Self-supporting installation

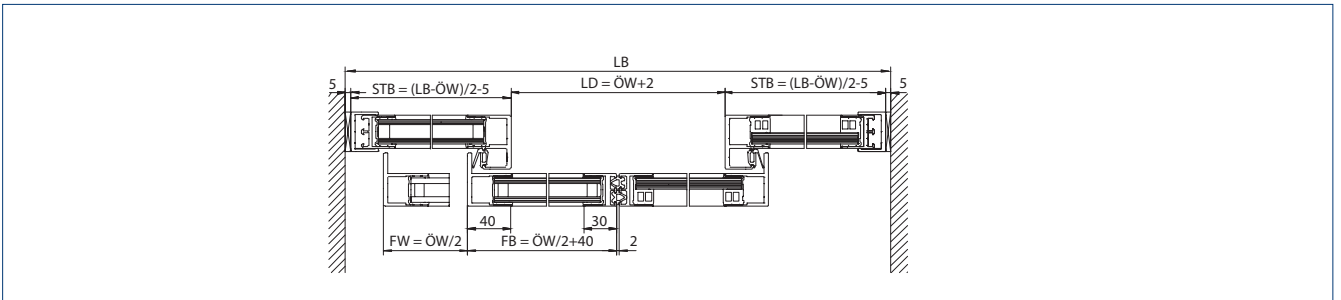

Installation: Wall installation with longer drive and girder section between the walls

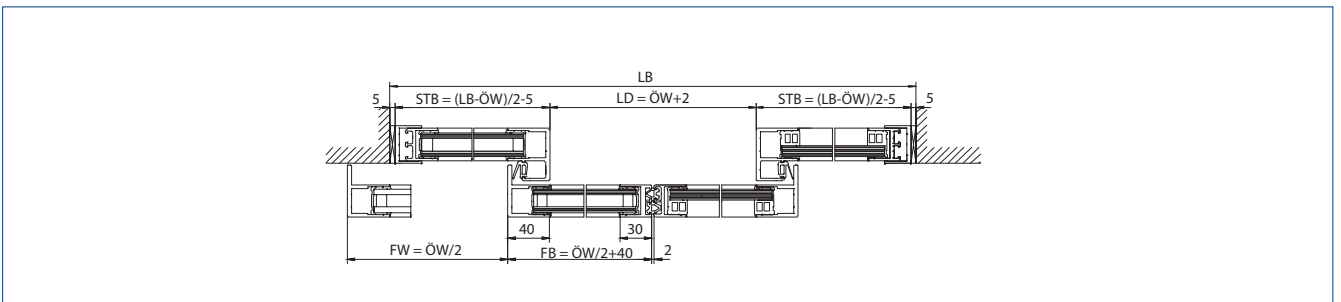

Installation: Wall installation

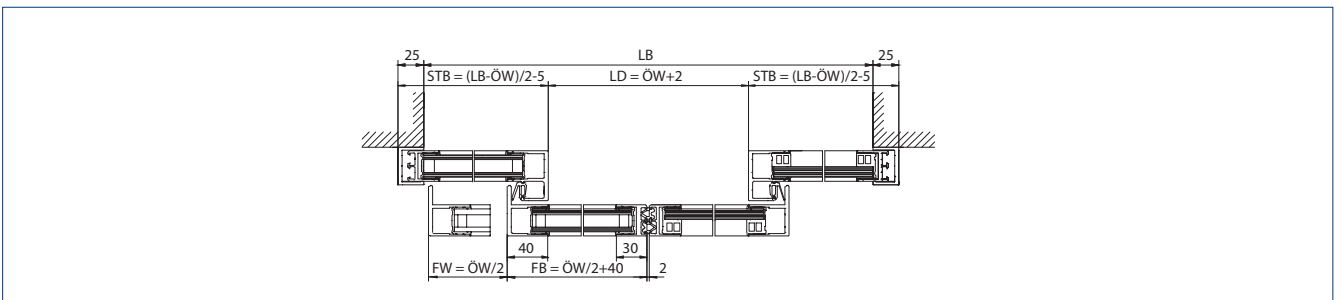

LB = Clear installation width | LD = Clear passage | FW = Travel path | FB = Leaf width | STB = Side screen width | DH = Passage height | ÖW = Opening width

WITH TOUGHENED SAFETY GLASS CLAMPING FITTING – WITHOUT SIDE SCREEN

Drawing no. 70506–ep03

Floor guide: For floor mounting

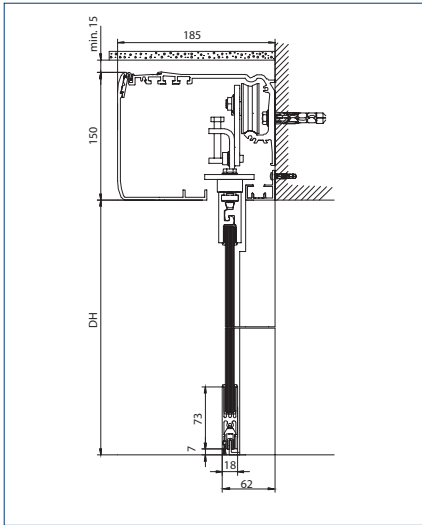

Floor guide: Adjustable for wall installation

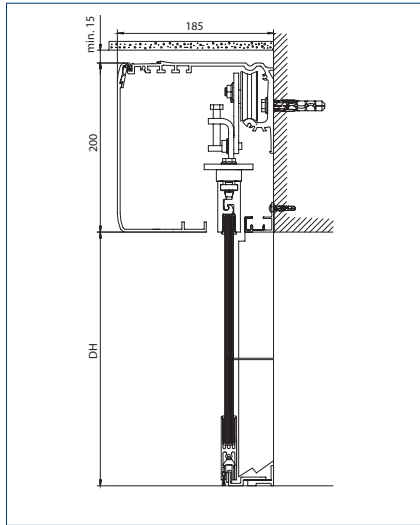

1-leaf door system

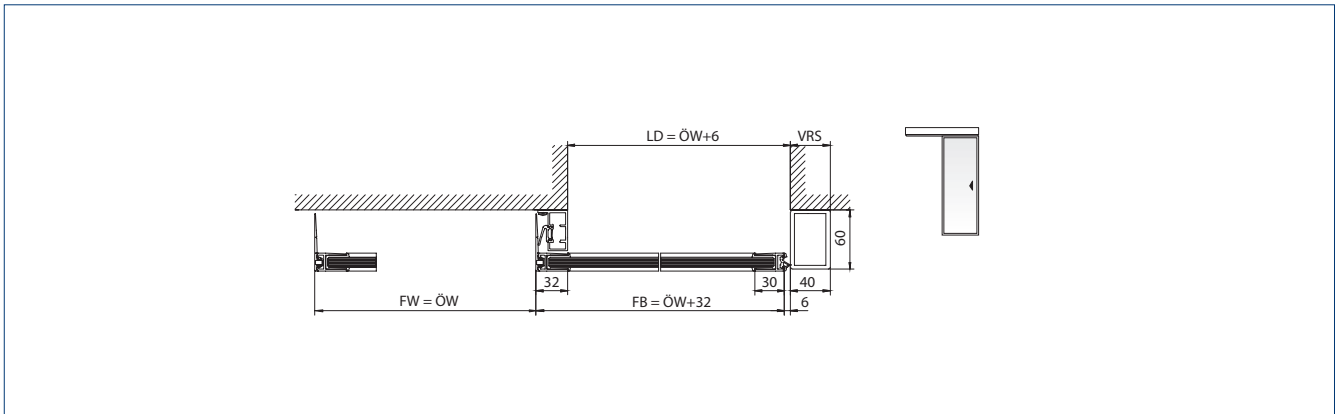

2-leaf door system

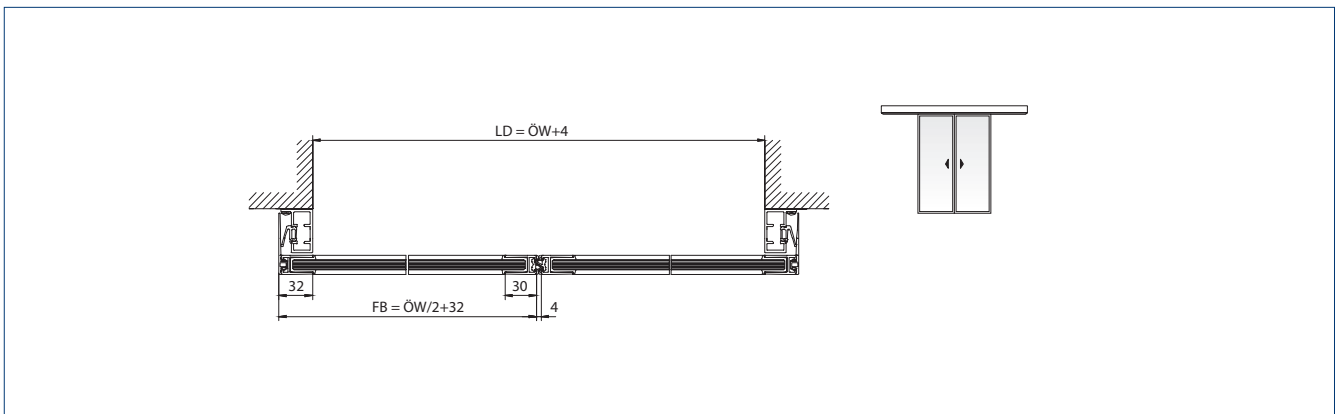

LD = Clear passage | FW = Travel path | FB = Leaf width | ÖW = Opening width | VRS = Drive extension right | DH = Passage height

**WITH TOUGHENED SAFETY GLASS CLAMPING FITTING – WITH SIDE SCREEN**

Drawing no. 70506–ep04

Door system with door leaf and side screens under drive

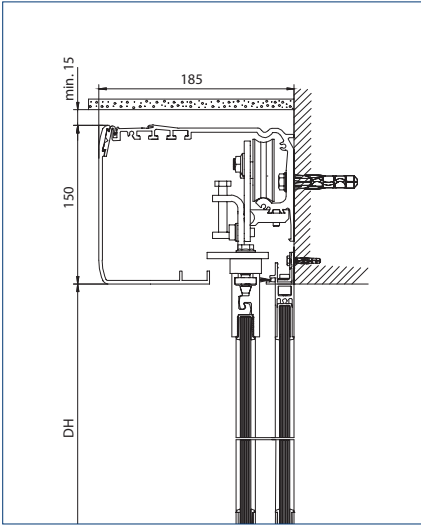

Door system with door leaf and side screens under drive

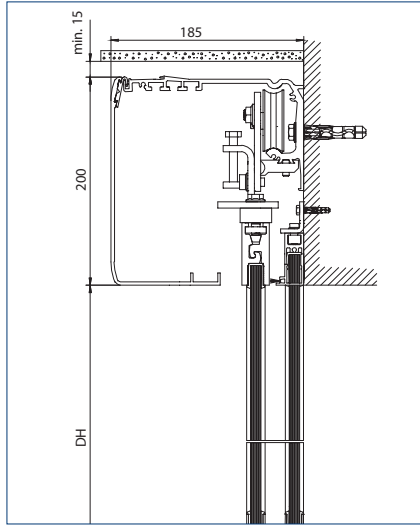

Door system with door leaf and side screens under girder section

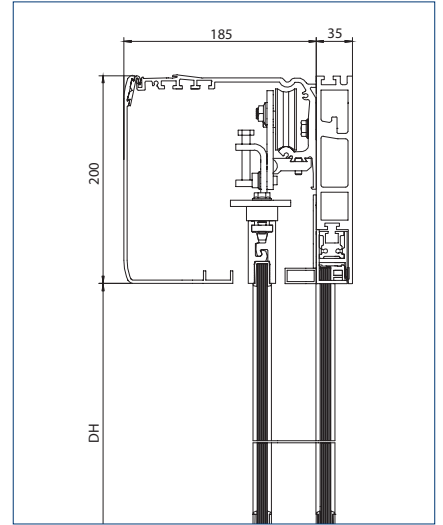

→ **Note:** See installation drawing for area of application

Installation: Self-supporting installation

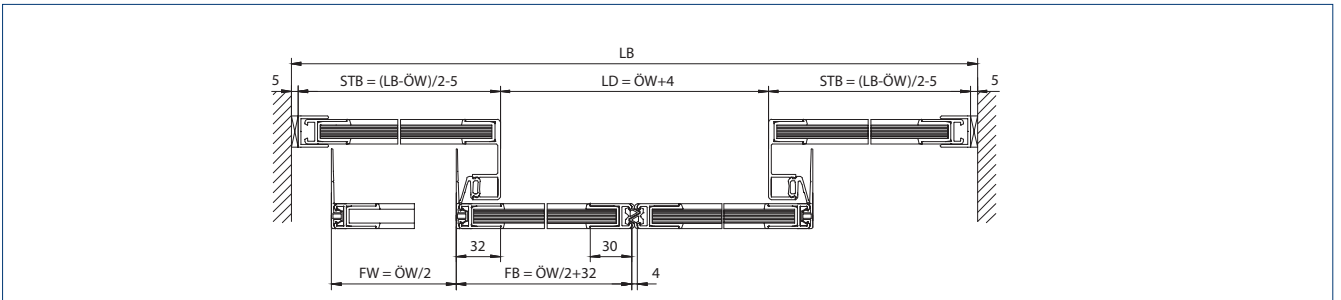

Installation: Wall installation with longer drive and girder section between the walls

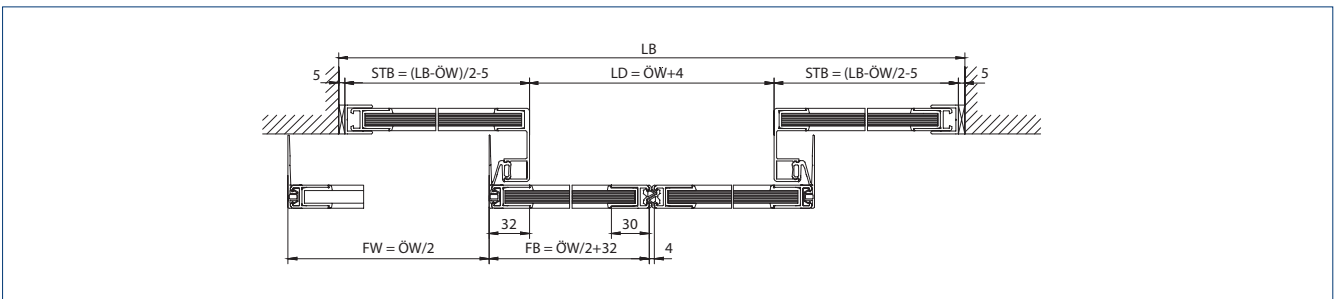

Installation: Wall installation with girder section

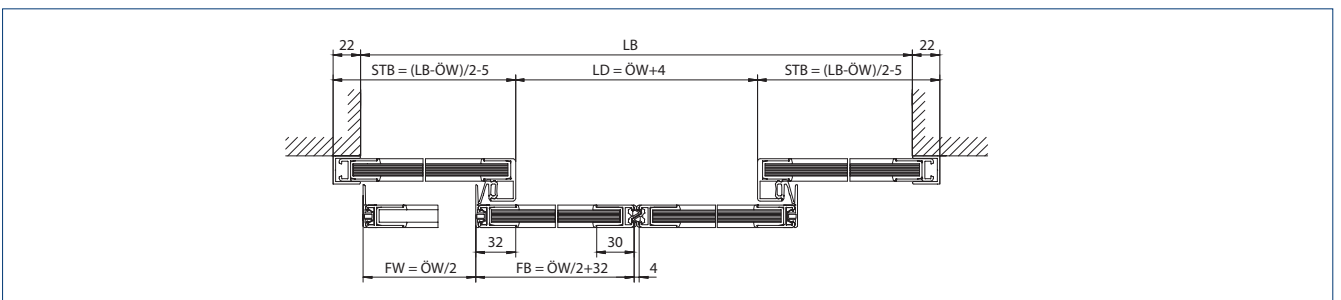

LB = Clear installation width | STB Side screen width | LD = Clear passage | FW = Travel path | DH = Passage height | FB = Leaf width | ÖW = Opening width





SLIDING DOOR

# Sliding door systems special variants

We have a diverse range of special variants on offer for all structural conditions for which standard variant sliding door systems are not suitable. Do not hesitate to contact us if you need information: for example, for use in narrow glass façades or with special burglary resistance. We can find the right individual sliding door system for you among the many GEZE Slim-drive variants.



# Sliding door systems special variants

## SOLUTIONS FOR SPECIAL PURPOSES

The Slimdrive SL drive is available in numerous special variants. These are always used when the standard variant of the sliding door system is not suitable.

- **Slimdrive SLT:** Use in slim glass façades for 2- or 4-leaf doors.
- **Slimdrive SL RC2:** Sliding doors with burglar resistance in accordance with resistance class 2. Also optionally available as a variant for escape and rescue routes (SL RC2-FR).
- **Slimdrive SL-BO:** This variant is used in escape and rescue routes. In addition to the sliding function, the doors can be swung open using a turn-tilt fitting.
- **Slimdrive SL-T30:** For applications where both fire-retardant doors in accordance with DIN 4102 and smoke-proof doors in accordance with DIN 18095 are necessary.
- **Slimdrive SLV:** This variant can be used for corner sliding doors with angles between 90° and 270°.
- **Slimdrive SL inclined:** For the use of 2-leaf sliding doors in inclined glass façades with opening widths of up to 2500mm.



Slimdrive SLT with IGG, Café Luitpold Munich, Germany (photo: Robert Sprang)

# Slimdrive SLT



Automatic telescopic sliding door system for use  
in extremely narrow glass façades

## AREAS OF APPLICATION

- Double and four leaf sliding door systems
- If space is limited with low clear opening width or little space next to the door opening
- Interior and exterior doors with high access frequency
- Opening widths from 1000 to 3600 mm possible
- Door leaf weights up to 80 kg per leaf
- Suitable profile systems are fine-framed profile systems with ISO Glass and integrated all-glass systems (IGG)

## PRODUCT FEATURES

- Two parallel tracks carry the door leaf and thus achieve large opening widths
- Very quiet-running, low-wear direct current drive with height of only 7 cm
- Can be networked, and integrated into the building automation via open standard (BACnet)
- Independent error recognition and recording
- Freely configurable inputs and outputs for different functions
- Integrated rechargeable battery for emergency opening and closing in the event of a power failure
- Various mechanical and electrical locks are optionally available

TECHNICAL DATA

	SLT	SLT-FR
For 1-leaf door systems	-	-
For 2-leaf door systems	●	●
For 4-leaf door systems	●	●
Height	70 mm	
Depth	247 mm	
Leaf weight (max.) 2-leaf	80 kg	
Leaf weight (max.) 4-leaf	70 kg	
Opening width 2-leaf	1000 – 3000 mm	
Opening width 4-leaf	1600 – 3600 mm	
Temperature range	-15 to 50 °C	
Disconnection from mains	Main switch in the drive	
Opening speed (max.)	0.8 m/s	
Closing speed (max.)	0.8 m/s	
Hold-open time	0 to 60 s	
Adjustable opening and closing force (max.)	150 N	
Automatic adaptation to traffic flow	●	●
Automatic reversal when an obstacle is detected	●	●
Pharmacy opening	●	●
Interlocking door system function	●	-
Vestibule function	●	-
Automatic opening in the event of a power failure	adjustable	standard
Automatic closing in the event of a power failure	adjustable	not available
Function in the event of a power failure	adjustable for 30 min / 30 cycles	open
Automatic opening in the event of a fault	not available	standard
Approvals	DIN 18650 EN 16005 DIN EN ISO 13849: Performance Level D	DIN 18650 EN 16005 DIN EN ISO 13849: Performance Level D AutSchR

● = yes | - = not available

DRIVE COMPONENTS



1 = Transformer | 2 = Locking mechanism | 3 = Control unit | 4 = Rechargeable battery | 5 = Motor

**TECHNICAL DATA**

	SLT	SLT-FR
<b>TRANSFORMER</b>	Ring core with protection and main switch	
Voltage	230 V	
Frequency	50 Hz	
Capacity rating	140 W	
<b>LOCKING MECHANISM</b>	Toothed belt locking, electro-magnetic, bi-stable	
<b>ROLLER CARRIAGE</b>		
Door leaf adjustment vertical	7 mm	
Door leaf adjustment horizontal	7 mm	
Tiling protection	Optional	
Self-cleaning	-	-
<b>CONTROL UNIT</b>	DCU1-NT	DCU1-2M-NT
With fault memory	●	●
With memory for statistical data	●	●
Software update possible	●	●
Bus interface optional	●	●
Connection for fire alarm system	●	●
Power supply for peripherals	●	●
Programmable inputs	3 pc.	
Programmable outputs	2 pc.	
<b>RECHARGEABLE BATTERY</b>	NiCd, 24 V, 700 mAh	
<b>MOTOR</b>	Motor gear unit	Double motor gear unit
Torque	400 Ncm	

● = yes | - = not available

**FITTING VARIANTS**

Door fittings	SLT
ISO glass fine-framed	●
MONO glass fine-framed	-
GCprofile Therm, energy-efficient profile system fine-framed	-
Toughened safety glass clamping profile	-
All-glass system (GGS)	-
Integrated all-glass system (IGG)	●
Wooden leaf (on-site)	-

● = yes | - = not available

**CALCULATION OF THE DRIVE LENGTH AL IN MM\***

	Slimdrive SLT		Slimdrive SLT-FR	
	Opening width (ÖW)	Drive length (AL)	Opening width (ÖW)	Drive length (AL)
4-leaf	1600 – 1999	$\ddot{O}W + 1180$	1600 – 1999	$\ddot{O}W + 1180$
	2000 – 3600	$1.5 \times \ddot{O}W + 150$	2000 – 3600	$1.5 \times \ddot{O}W + 150$
2-leaf left hand slide to open	1000 – 1360	$\ddot{O}W + 770$	1000 – 1560	$\ddot{O}W + 870$
	1360 – 3000	$1.5 \times \ddot{O}W + 90$	1560 – 3000	$1.5 \times \ddot{O}W + 90$
2-leaf right hand slide to open	1000 – 1460	$\ddot{O}W + 780$	1000 – 1660	$\ddot{O}W + 880$
	1460 – 3000	$1.5 \times \ddot{O}W + 50$	1660 – 3000	$1.5 \times \ddot{O}W + 50$

\* = Minimum overall length of the complete system with profile system ISO glass fine-framed



**Note:**



Opening widths of escape route sliding doors < 1000 mm are only permitted in exceptional cases. A continuous floor guide is generally recommended for outdoor systems. The minimum opening widths depend on the requirements of building law.

**CALCULATION OF LEAF AND GLASS DIMENSIONS IN MM**

depending on the opening width and passage height

		Internal leaf	External leaf
Leaf width	2-leaf	$\ddot{O}W / 2 + 40$	
	4-leaf	$\ddot{O}W / 4 + 40$	
Leaf height	2 or 4-leaf	$DH - 17$	
Glass width	2-leaf	$\ddot{O}W / 2$	$\ddot{O}W / 2 - 10$
	4-leaf	$\ddot{O}W / 4$	$\ddot{O}W / 4 - 10$
Glass height	2 or 4-leaf	$FH - 90$	$FH - 90$
Glass thickness		22	22

→ **Note:** max. leaf ratio width to height 1:4 or 1:5 in the case of 4-leaf systems, ÖW 1600 – 2000 mm

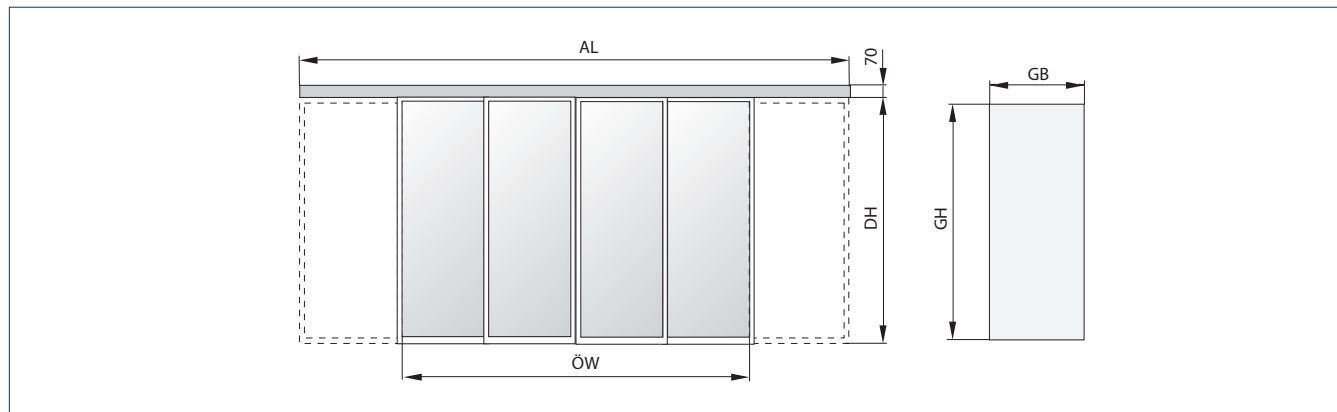

AL = Drive length | DH = Passage height | GB = Glass width | GH = Glass height | ÖW = Opening width

**WITH ISO/MONO GLASS FITTING – WITH SIDE SCREEN**

Drawing no. 70717-ep02 + 70717-ep04

Low girder section

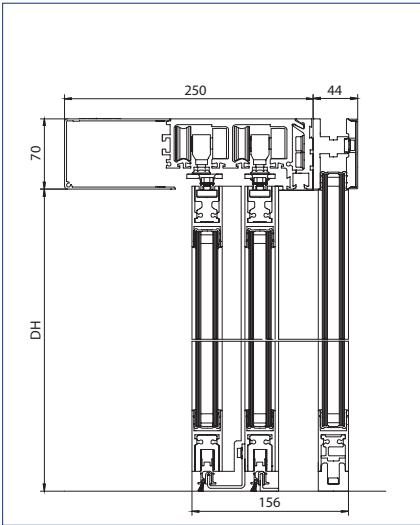

High girder section

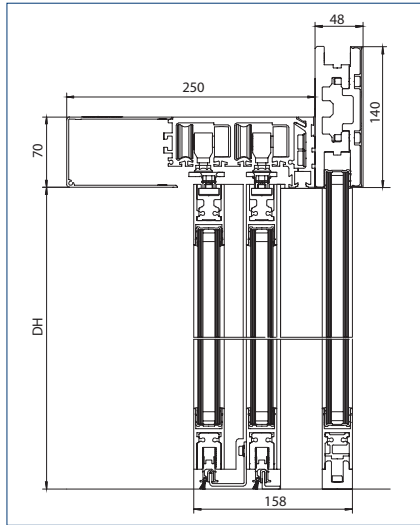

Installation: Self-supporting installation

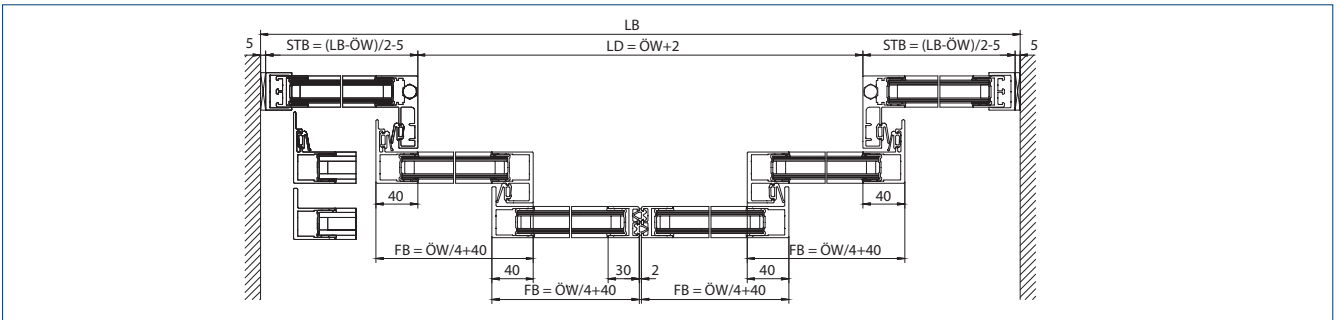

Installation: Wall installation with longer drive and girder section between the walls

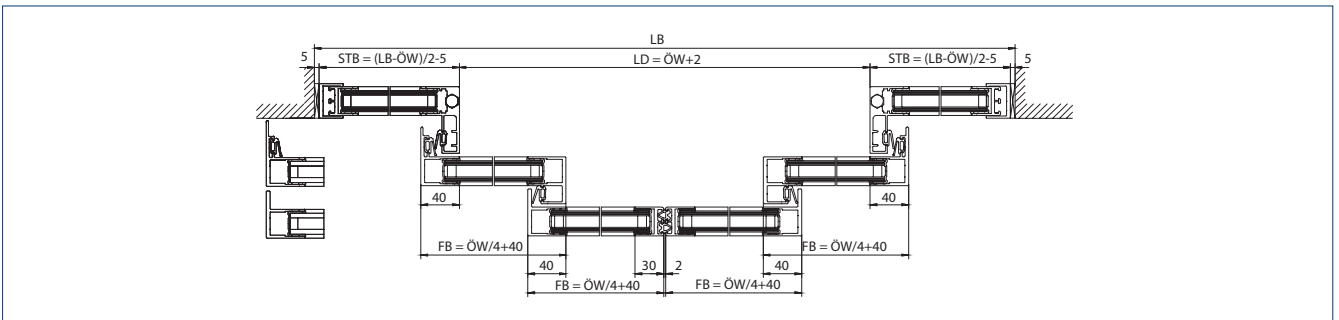

Installation: Wall installation

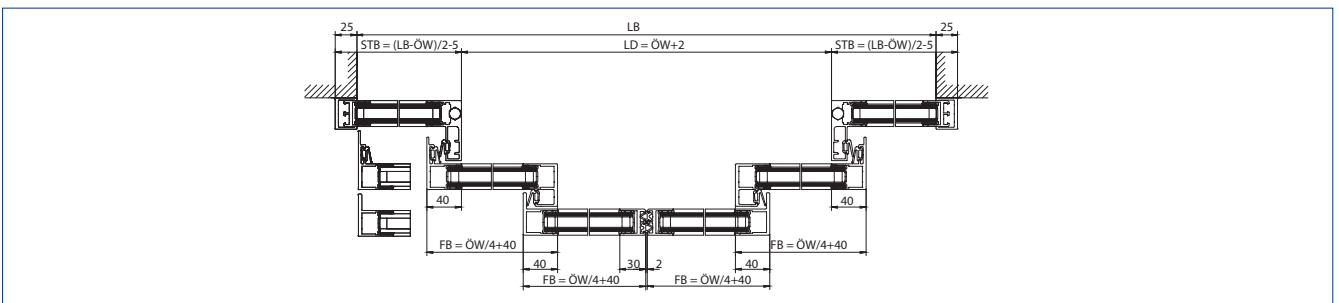

LB = Clear installation width | STB = Side screen width | LD = Clear passage | FB = Leaf width | ÖW = Opening width | DH = Passage height

→ **Note:** See installation drawing for area of application

WITH ISO/MONO GLASS FITTING – WITHOUT SIDE SCREEN

Drawing no. 70487-ep01

Floor guide: For floor mounting

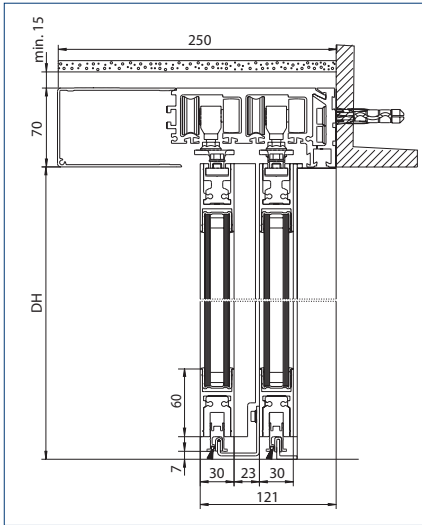

Floor guide: Adjustable for wall installation

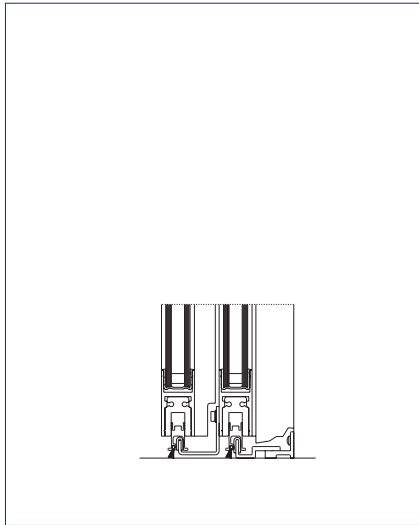

Floor guide: Continuous

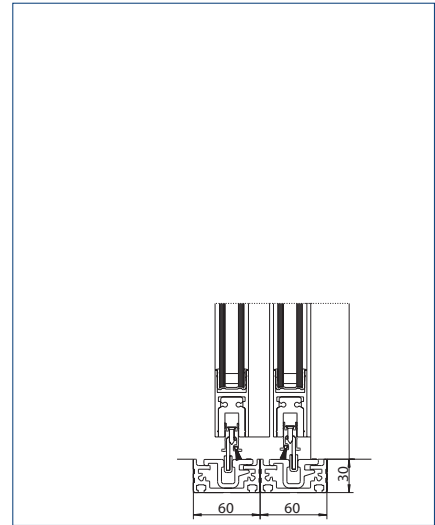

1-leaf door system

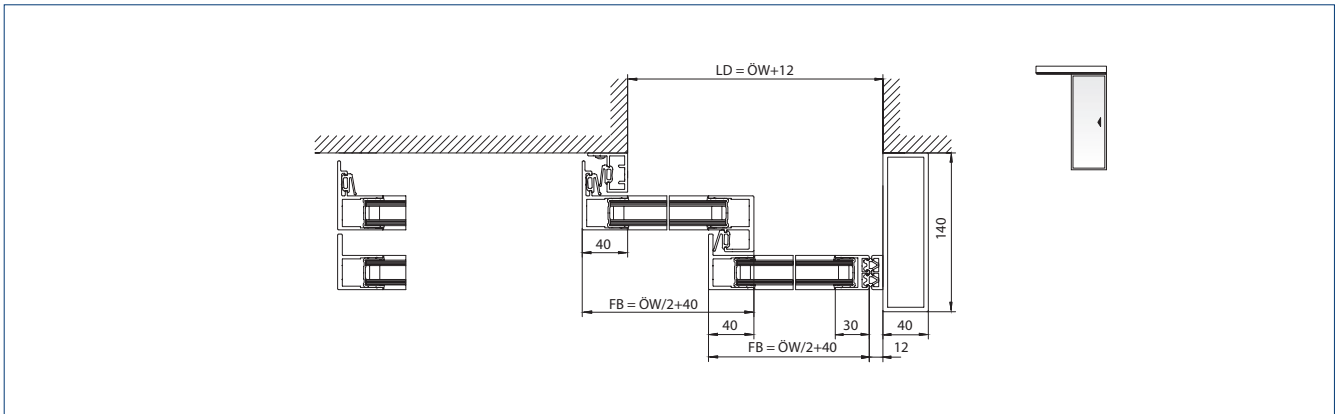

2-leaf door system

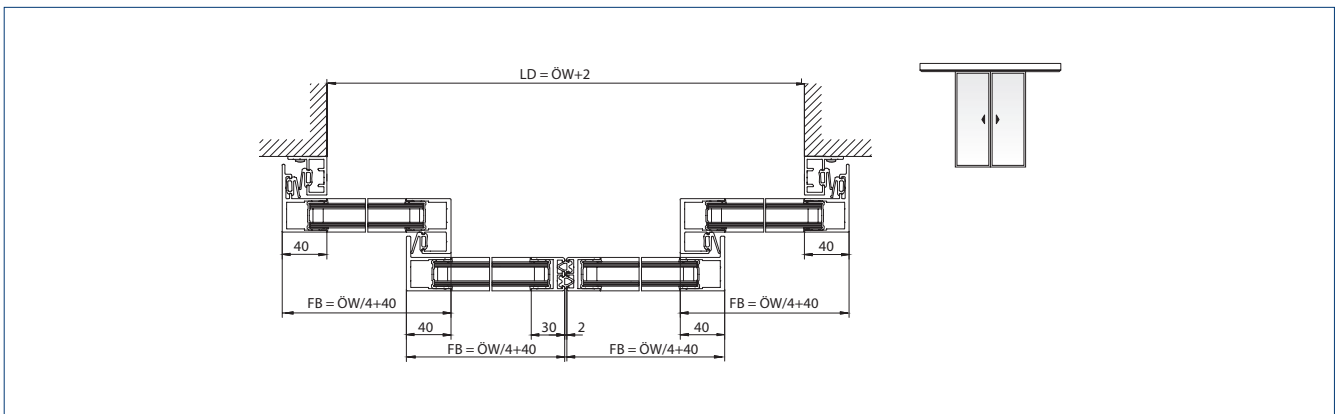

LD = Clear passage | FB = Leaf width | ÖW = Opening width | DH Passage height

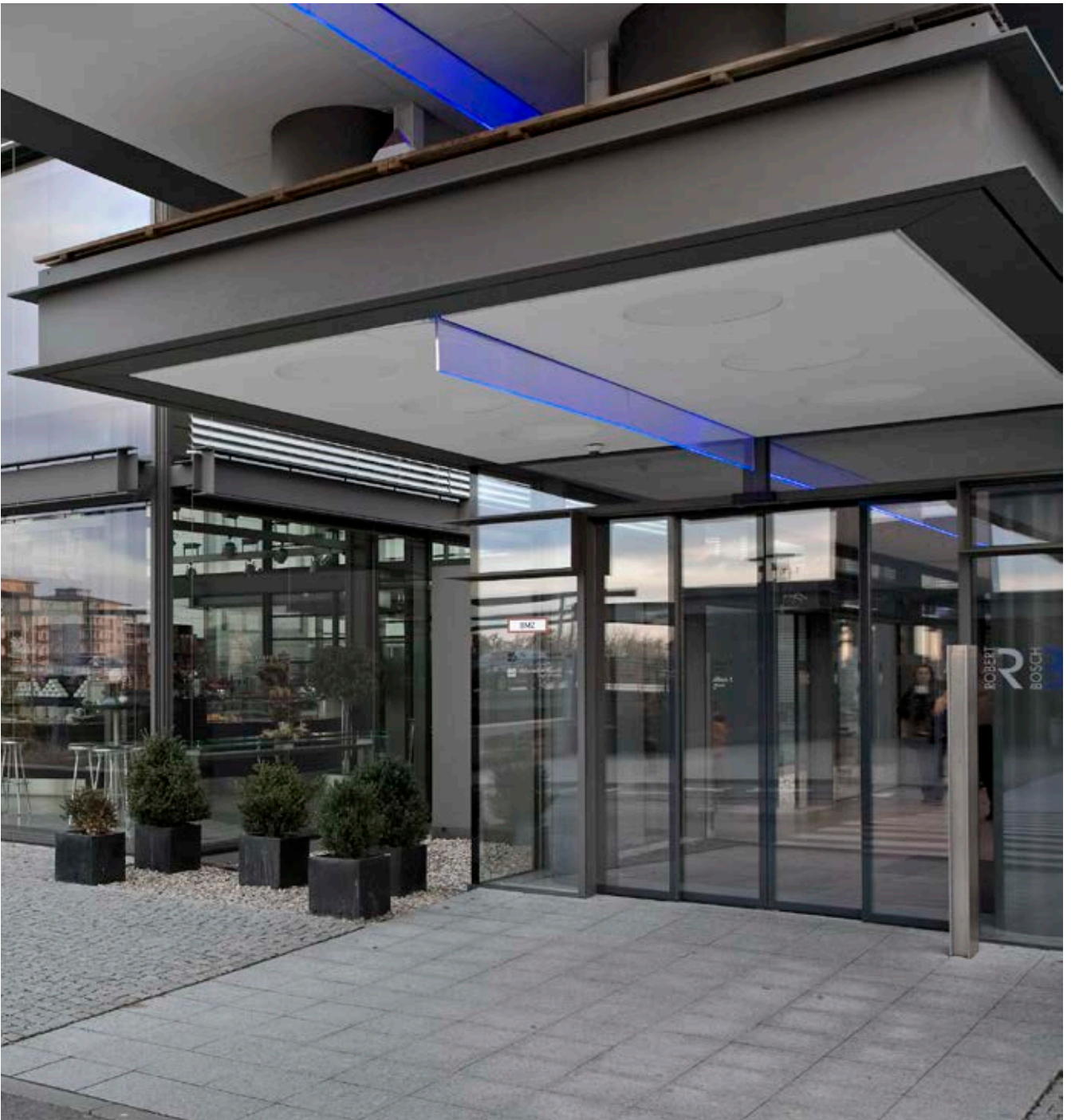

Slimdrive SLT-FR + IGG, Robert Bosch Hospital (photo: GEZE GmbH)

# Slimdrive SL RC2



Automatic linear sliding door system with burglar resistance in accordance with resistance class RC2

## AREAS OF APPLICATION

- Single and double leaf sliding door systems
- Interior and exterior doors with maximum security requirements
- Opening widths from 800 to 3000 mm possible
- Door leaf weight of up to 120 kg per leaf
- Suitable profile systems are fine-framed profile system with ISO and MONO glass according to resistance class RC2

## PRODUCT FEATURES

- Certified burglar resistance according to resistance class RC2
- Function RC2 is only available in "Night" mode of operation, in which the door is locked with rod locking
- Fitted with rod locking and reinforced profile components
- Very quiet-running, low-wear direct current drive with height of only 7 cm
- Can be networked, and integrated into the building automation via open standard (BACnet)
- Independent error recognition and recording
- Freely configurable inputs and outputs for different functions
- Integrated rechargeable battery for emergency opening in the event of safety-relevant faults such as a power failure



Hyco Grand Centre, Zagreb, Croatia (photo: Robert Les)



Sihlpost Switzerland (photo: Lorenz Frey / GEZE GmbH)

**CALCULATION OF THE DRIVE LENGTH AL IN MM\***

	Slimdrive SL RC2		Slimdrive SL-FR RC2**	
	Opening width (ÖW)	Drive length (AL)	Opening width (ÖW)	Drive length (AL)
2-leaf	900 – 1000	$\ddot{O}W + 1100$	900 – 1000	$\ddot{O}W + 1100$
	1000 – 3000	$2 \times \ddot{O}W + 100$	1000 – 3000	$2 \times \ddot{O}W + 100$
1-leaf left hand slide to open	800 – 3000	$2 \times \ddot{O}W + 120$	800 – 870	$\ddot{O}W + 990$
			870 – 3000	$2 \times \ddot{O}W + 120$
1-leaf right hand slide to open	800 – 3000	$2 \times \ddot{O}W + 120$	800 – 820	$\ddot{O}W + 940$
			820 – 3000	$2 \times \ddot{O}W + 120$

\* = Minimum installation length of the complete system with profile system ISO glass fine-framed | \*\* For FR variants (FR-RWS, FR-LL) request drawing!

→ → → **Note:**



Opening widths of escape route sliding doors < 1000 mm are only permitted in exceptional cases. The minimum opening widths depend on the requirements of building law.

**CALCULATION OF LEAF AND GLASS DIMENSIONS IN MM (ISO GLASS PROFILE SYSTEM)**

		ISO glass (in accordance with RC2)
Leaf width	1-leaf	$\ddot{O}W + 40$
	2-leaf	$\ddot{O}W / 2 + 40$
Leaf height	1-leaf / 2-leaf	$DH - 17$
Glass width	1-leaf	$\ddot{O}W - 23$
	2-leaf	$\ddot{O}W / 2 - 23$
Glass height	1-leaf / 2-leaf	$FH - 93$
Glass thickness	1-leaf / 2-leaf	max. 23

→ **Note:** max. leaf ratio width to height 1:4

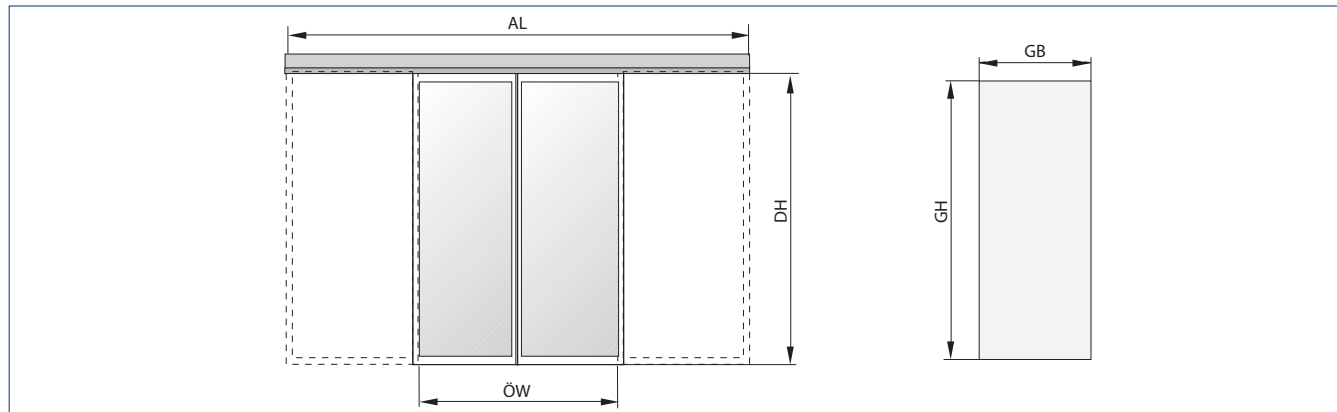

AL = Drive length | DH = Passage height | GB = Glass width | GH = Glass height | ÖW = Opening width

→ **Note:** The burglar-resistant function RC2 is only enabled in the "NIGHT" mode of operation. In the "NIGHT" mode of operation, the door does not fulfil any escape route demands. It is therefore important to ensure that there is nobody in the building or that sufficient other escape route doors are available.

**WITH ISO/MONO GLASS FITTING – WITHOUT SIDE SCREEN**

Drawing no. 70484-ep48/50/52/54

→ **Note:** Selected illustrations; for further installation situations, see installation drawing.

Floor guide: selectively with reinforced supporting bracket

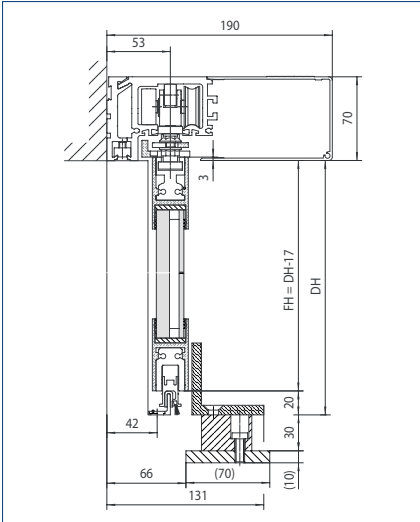

Floor guide: continuous with reinforced supporting bracket

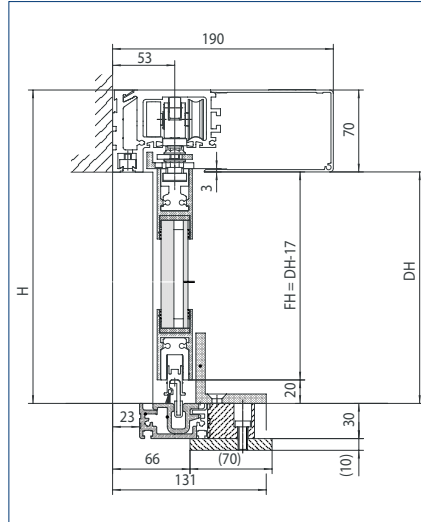

1-leaf door system

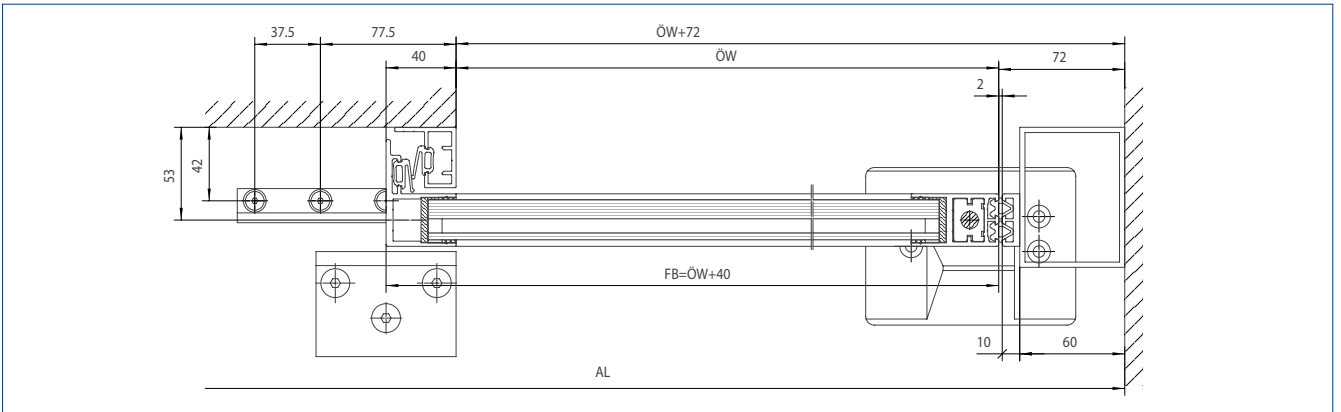

2-leaf door system

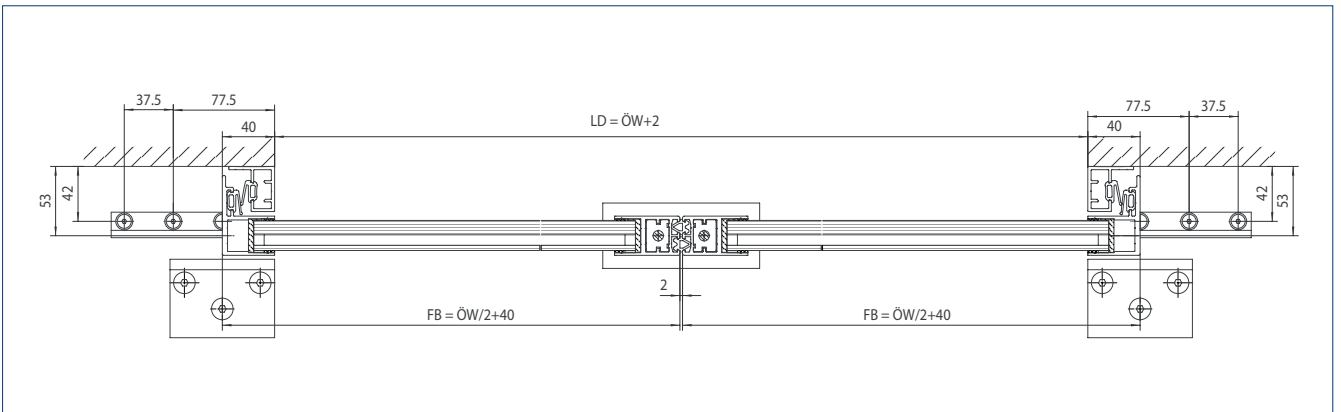

AL = Drive length | DH = Passage height | LD = Clear passage | FB = Leaf width | FH = Leaf height | ÖW = Opening width | H = Total height of sliding door system

→ **Note:** For fastening specifications, see drawing no. 70484-ep46/47

WITH ISO/MONO GLASS FITTING – WITH SIDE SCREEN

Drawing no. 70484-ep49/51/53/55

→ **Note:** Selected illustrations; for further installation situations, see installation drawing.

Floor guide: selectively with reinforced supporting bracket

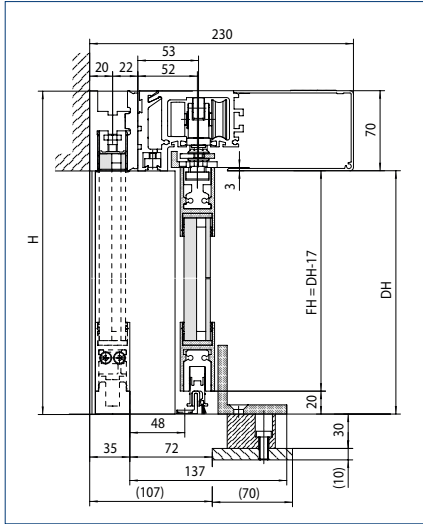

Floor guide: continuous with reinforced supporting bracket

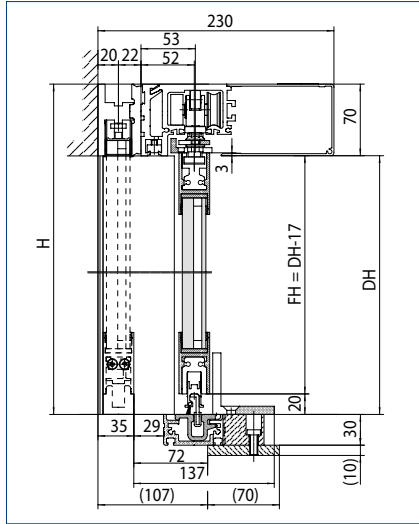

1-leaf door system

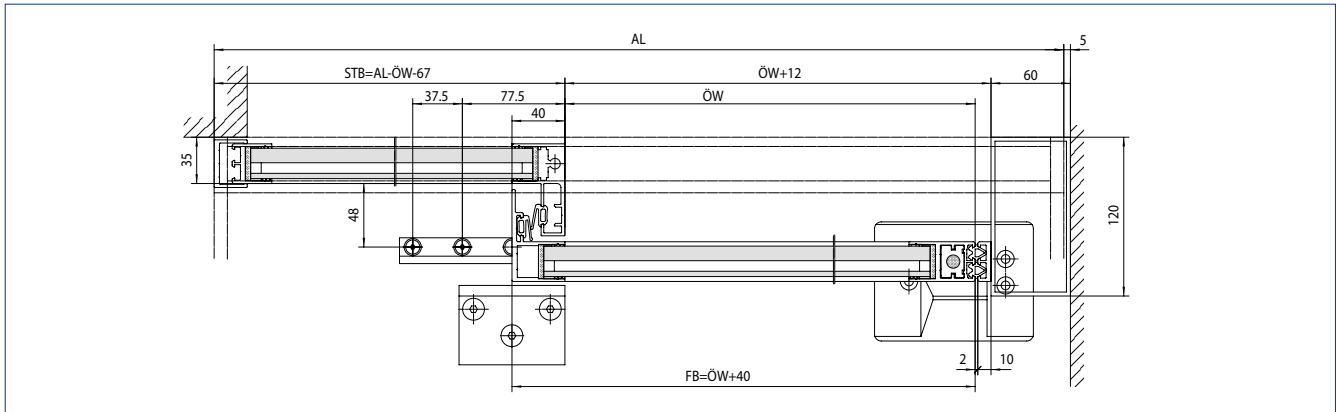

Installation: Wall installation

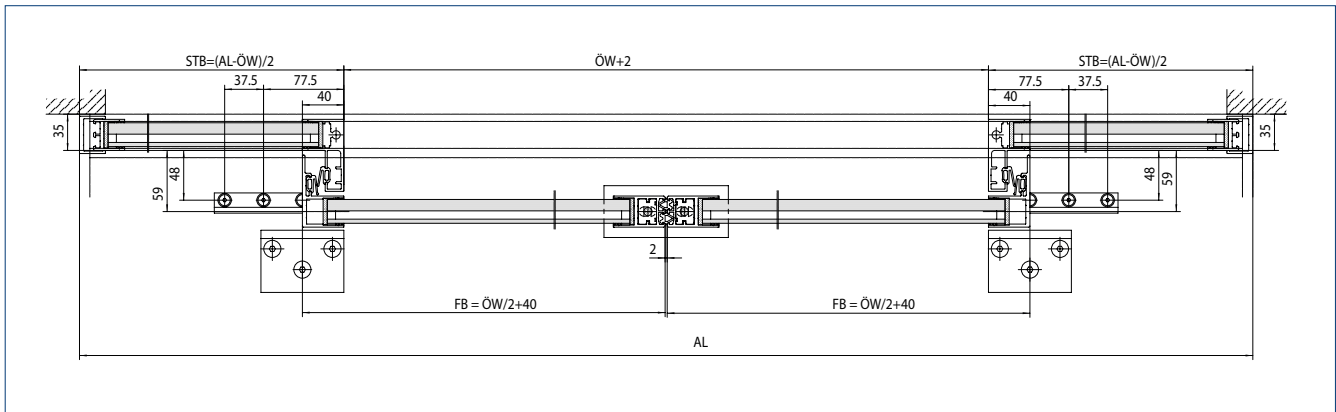

AL = Drive length | FB = Leaf width | DH = Passage height | ÖW = Opening width | H = Total height of sliding door system | STB = Side screen width

→ **Note:** See installation drawing for area of application

→ **Note:** For fastening specifications, see drawing no. 70484-ep46/47



Sihlpost Switzerland (photo: Lorenz Frey / GEZE GmbH)

# Slimdrive SL-BO



## Automatic sliding door system for escape and rescue routes with break-out function

### AREAS OF APPLICATION

- Single and double leaf sliding door systems along escape and rescue routes
- Interior and exterior doors with maximum security requirements
- Façades with slim mullion-transom constructions
- Opening widths from 900 to 2500 mm possible
- Door leaf weights of up to 100 kg per leaf
- Suitable profile systems are fine-framed profile system with ISO and MONO glass

### PRODUCT FEATURES

- Function BO allows the leaf and side screens to swing open in the direction of escape
- Electrical locking mechanisms for "Night" mode of operation integrated
- Very quiet-running, low-wear direct current drive with height of only 7 cm
- Can be networked, and integrated into the building automation via open standard (BACnet)
- Independent error recognition and recording
- Freely configurable inputs and outputs for different functions
- Integrated rechargeable battery for emergency opening in the event of safety-relevant faults such as a power failure
- Self-cleaning roller carriage reduces maintenance effort and costs
- Various mechanical and electrical locks are optionally available

WITH ISO/MONO GLASS FITTING

Drawing no. 70485-ep51

Door system with door leaf and side screens

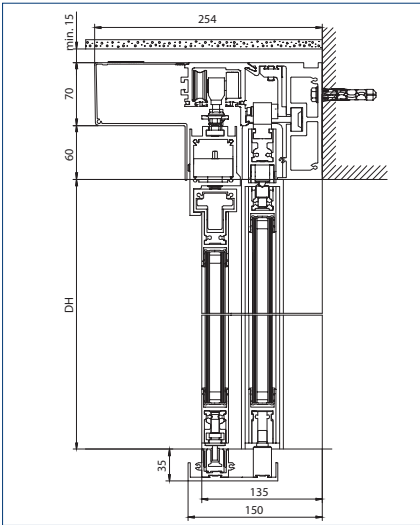

Installation: Self-supporting installation

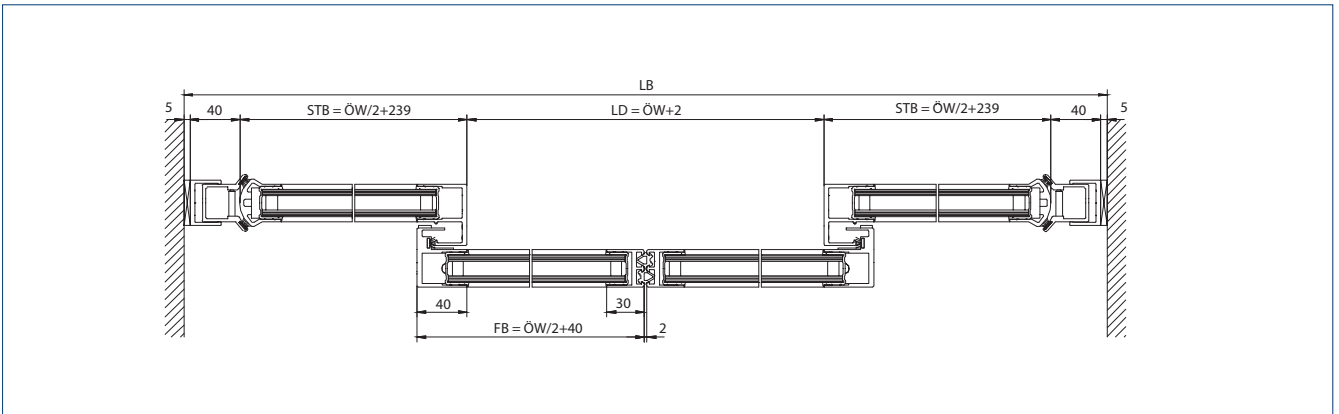

Installation: Wall installation

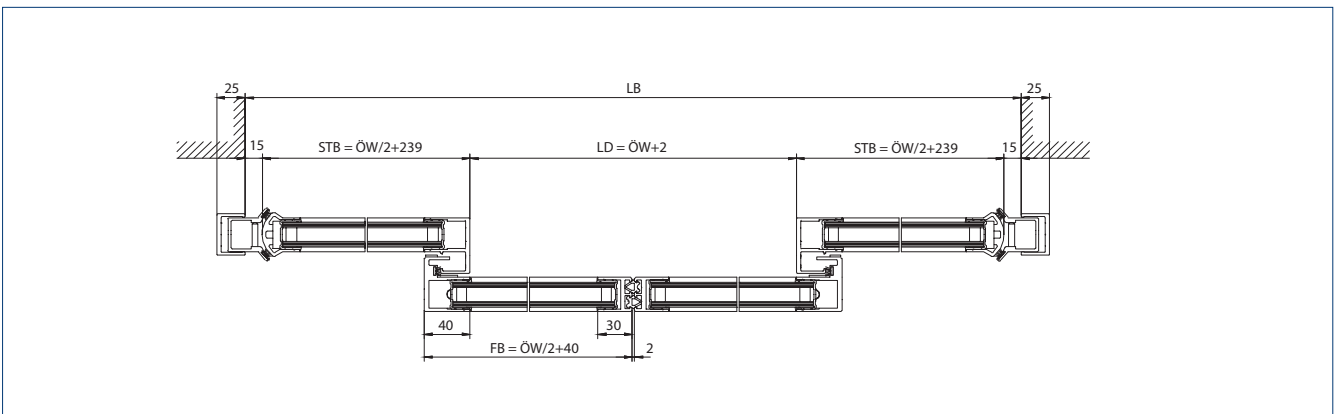

LB = Clear installation width | STB Side screen width | LD = Clear passage | FB = Leaf width | ÖW = Opening width | DH = Passage height



Auditorium centre Klinikum to the right of the Isar, Munich, Germany (photo: Robert Sprang)



Slimdrive SL-BO automatic sliding door drive, installed at Madrid-Barajas airport (photo: Rafael Vargas / GEZE GmbH)

# Slimdrive SL-T30



## Automatic sliding door drive for fire protection doors with resistance class T30

### AREAS OF APPLICATION

- Single and double leaf sliding door systems
- Door leaf weight of up to 120 kg per leaf
- Opening widths from 900 to 2500 mm possible

### PRODUCT FEATURES

- Very quiet-running, low-wear direct current drive with height of only 7 cm
- Independent error recognition and recording
- Various mechanical and electrical locks are optionally available

# Slimdrive SLV



## Automatic sliding door system for use on angled façades or corners

### AREAS OF APPLICATION

- Double leaf sliding door systems
- Use on angled façades or corners
- Interior and exterior doors with high access frequency
- Façades with slim mullion-transom constructions
- Glass façades with maximum design demands
- Opening widths from 900 to 2500 mm possible
- Door leaf weight of up to 120 kg per leaf
- Suitable profile systems are fine-framed profile system with ISO and MONO glass
- Suitable for various profile systems

### PRODUCT FEATURES

- Product is projected and manufactured building-specifically
- Very quiet-running, low-wear direct current drive with height of only 7 cm
- Angle in the drive rail 90° to 270°
- Can be networked, and integrated into the building automation via open standard (BACnet)
- Independent error recognition and recording
- Freely configurable inputs and outputs for different functions
- Integrated rechargeable battery for emergency opening and closing in the event of a power failure
- Self-cleaning roller carriage reduces maintenance effort and costs
- Various mechanical and electrical locks are optionally available



Slimdrive SLV automatic sliding door drive (corner sliding door), Hotel Parador National del Saler, Valencia (photo: Pau Esculies / GEZE GmbH)



Häussler Global Office GmbH, Stuttgart, Germany (photo: Dirk Wilhelmy / GEZE GmbH)

# Slimdrive SL inclined



## Automatic linear sliding door system for use on inclined glass façades

### AREAS OF APPLICATION

- Double leaf sliding door systems
- Use on inclined glass façades in mullion-transom constructions
- Interior and exterior doors with high access frequency
- Opening widths up to 2500 mm possible
- Door leaf weights depending on the angle of inclination, up to 100 kg per leaf
- Suitable profile systems are fine-framed profile system with ISO and MONO glass

### PRODUCT FEATURES

- Freely selectable angle of inclination up to 9.9° (larger possible upon request)
- Continuous floor guide
- Very quiet-running, low-wear direct current drive with height of only 7 cm
- Integrated infrared movement detector
- Can be networked, and integrated into the building automation via open standard (BACnet)
- Independent error recognition and recording
- Adjustment options for all door motion parameters
- Freely configurable inputs and outputs for different functions
- Integrated rechargeable battery for emergency opening in the event of safety-relevant faults such as a power failure
- Self-cleaning roller carriage reduces maintenance effort and costs
- Various mechanical and electrical locks are optionally available



Villa Soravia, Millstatt, Carinthia, Austria (photo: Helmut Kolaric)

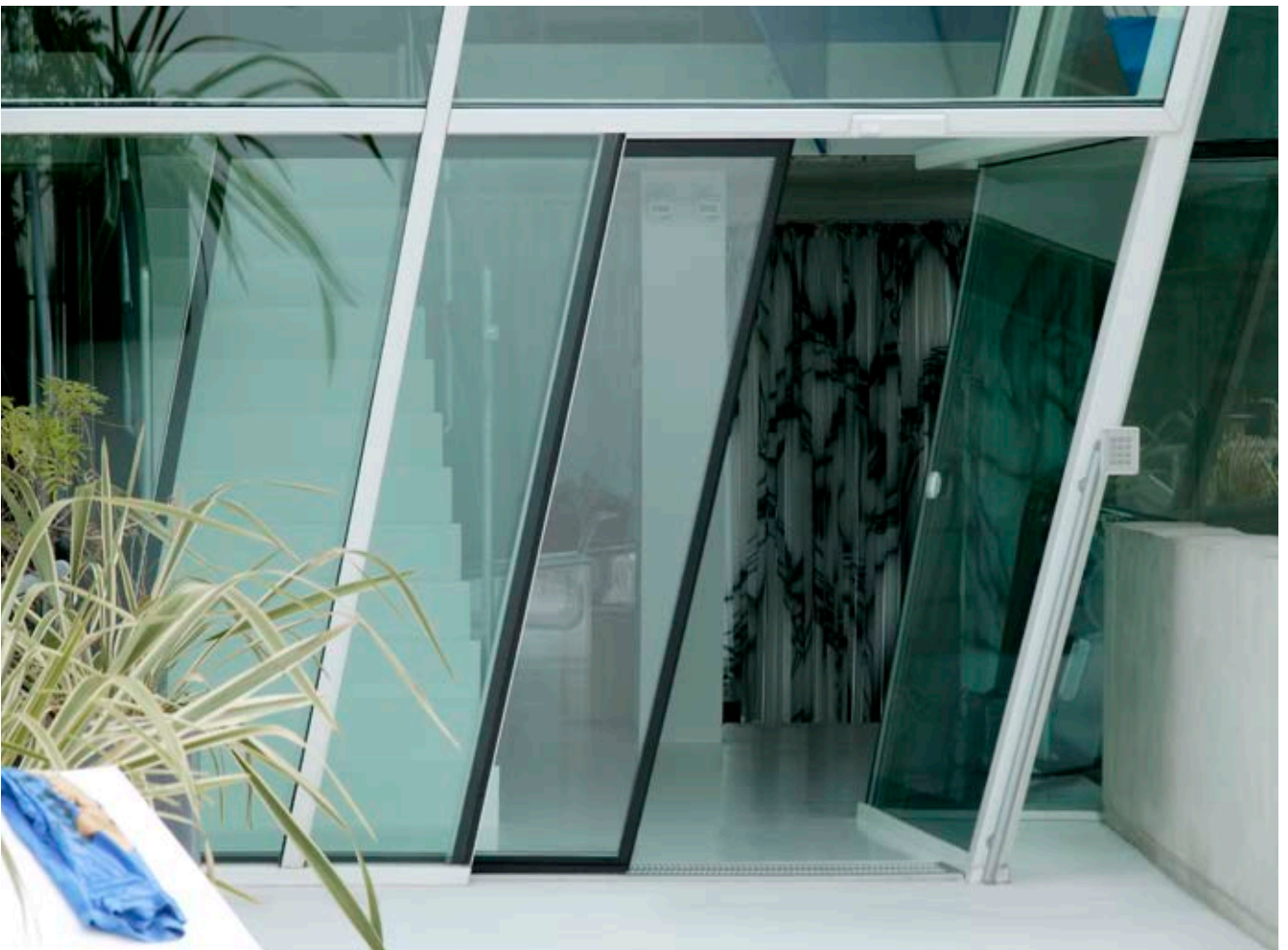

Villa Soravia, Millstatt, Carinthia, Austria (photo: Helmut Kolaric)





SLIDING DOOR

# Special functions escape and rescue routes

Special measures must be met for worst case scenarios. You're best equipped for any possible dangers with the redundant sliding doors by GEZE for escape and rescue routes. We have the right solution for all needs, depending on whether the escape route only leads in one direction, or – such as inside public buildings – in both directions. Thanks to intelligent controls and emergency opening equipment, our automatic sliding doors are always reliable, even in the event of a power failure.



# FR-LL



Sparkasse, Ulm, Germany (photo: Nikolaus Grünwald)

## Redundant sliding doors for escape and rescue routes with locked exit only function (one way)

### AREAS OF APPLICATION

- Use in the Slimdrive, ECdrive and Powerdrive product families
- For areas where the exit only mode of operation is supposed to be used for a longer period
- In particular in banks, theatres and universities

### PRODUCT FEATURES

- Type-tested FR-LL variants
- Greater security against unauthorised opening of the door from outside
- Permanently redundantly monitored locking mechanism
- Also locked by the intelligent control unit for night mode locking mechanism

# FR-DUO



Cafe Luitpold, Munich, Germany (photo: Robert Sprang)

## Redundant sliding doors for escape and rescue routes in both directions

### AREAS OF APPLICATION

- Use in the Slimdrive, ECdrive and Powerdrive product families
- For specific areas in public buildings, where escape must be possible in both directions
- In particular in office buildings, airports and stations

### PRODUCT FEATURES

- Type-tested automatic sliding door variants FR-DUO
- With bilaterally monitored movement detectors

# FR-RWS



Airport, Cologne-Bonn, Germany (photo: Martin Jakob)

## Redundant sliding doors for locked escape and rescue routes

### AREAS OF APPLICATION

- Use in the Slimdrive, ECdrive and Powerdrive product families
- In particular in airports, stations and senior and care homes

### PRODUCT FEATURES

- Setting by intelligent control unit and monitored locking mechanism possible
- Passage of the door then only possible upon request
- In the event of a power failure or other problems, the door reliably opens the escape route
- Additional locking mechanism with monitored duplicate processing system and redundant emergency opening button

# Sliding doors according to CO48 (France)



Grottes de Lascaux, France (photo: Jean-Luc Kokel)

## Sliding doors for escape and rescue routes according to CO48

### AREAS OF APPLICATION

- Use in the Slimdrive, ECdrive and Powerdrive product families
- Special variants for use in France and other regions where this solution is recognised

### PRODUCT FEATURES

- Single opening of the door in the event of power failure via the installed rubber cable





SLIDING DOOR

# Solutions and functions

Accessible toilets and vestibule systems – both function with automatic sliding door systems, but need special solutions. This means that accessible toilets must guarantee convenience and absolutely reliable operation and provide, for example, special emergency open push buttons. In contrast, for vestibule systems, you need radar movement detectors which detect directions. Whatever the use – we can offer you the right automatic sliding doors which meet your needs.



# Accessible toilet

Accessible toilets must be designed in such a way that people with all sorts of different handicaps can use the facilities without needing help. GEZE sliding door drives provide an indispensable service for this application, and guarantee a high level of convenience.

## FUNCTIONAL DESCRIPTION

The non-contact proximity switch is installed at hand height and detects persons and objects at a distance of 10 to 60 cm (adjustable). Approaching the switch is sufficient to open the door. When the "internal push button" is triggered with the door closed, the system switches into the exit only mode of operation, meaning the outer push button on the door can no longer open. Both proximity switches switch from green to red and signal that the WC is occupied.

The drive uses motor power to hold the door in the closed position. Triggering the "internal push button" again switches the mode of operation back to automatic. Both proximity switches switch from red to green. The door opens and the "external push button" is cleared again.

An optional pull switch can be used to transmit a message to an alarm system.

If the WC is occupied for longer than 30 minutes, a message is also transmitted to an alarm system or an optional audio alert.



1 = Non-contact proximity switch (internal and external) | 2 = emergency off switch (recommended installation height: 1600 mm) | 3 = active infrared light curtain | 4 = emergency call pull switch | 5 = sliding panel

# Vestibule systems

Vestibule systems are used to avoid draughts and reduce heat exchange. Preferably only one door should be opened.

Direction-detecting radar movement detector only activate the door when people move towards it. This means the door closes more quickly behind people. A separate programme switch is compulsory for door systems in escape and rescue routes.

Combination example 1

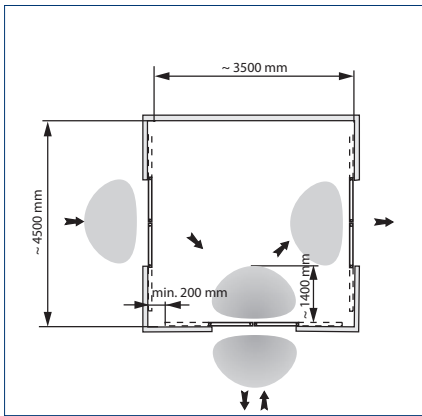

Combination example 2

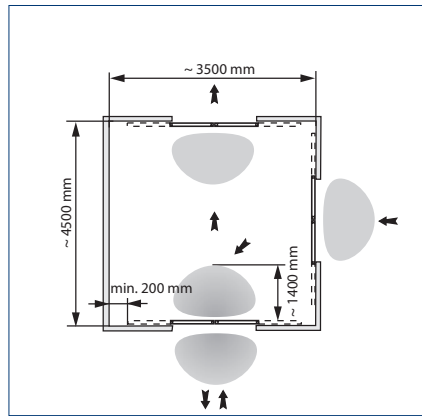

Combination example 3

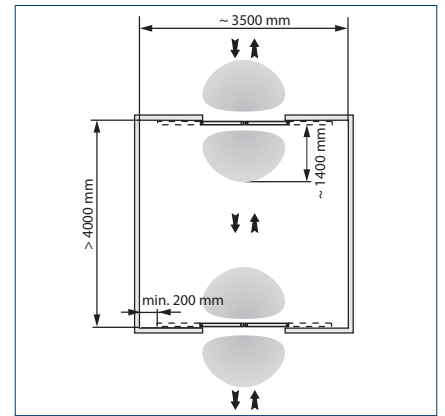

Combination example 4

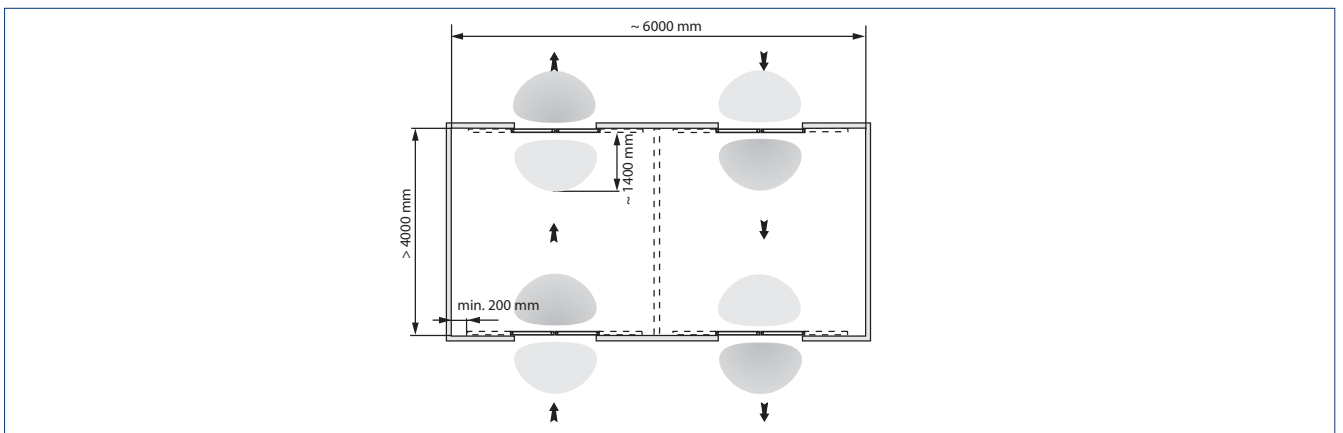

grey = Detection area





SLIDING DOOR

# Sliding door fittings

Nothing works without door fittings ... You need the right sliding door fittings for your automatic sliding doors to open and close perfectly. Plan according to your wishes and needs, depending on the appearance, function or special circumstances. The GEZE range of products meets a wide variety of needs where door fittings are concerned: including energy-efficient sliding door systems, all-glass systems, doors with a focus on hygiene or a variety of materials.



# Fitting variants

## GEZE SUPPLIES THE FOLLOWING FITTING VARIANTS FOR SLIDING DOOR SYSTEMS:

### ISO GLASS FINE-FRAMED

Attractive door leaves with an extremely slim aluminium frame. They combine the advantages of the frame (e.g. seals) with an inconspicuous design.

### MONO GLASS FINE-FRAMED

Same frame as with the ISO variant, but with one single glass pane made of 10 mm toughened safety glass or laminated safety glass.

VSG = Verbund-Sicherheits-Glas (laminated safety glass)

ESG = Einscheiben-Sicherheits-Glas (toughened safety glass)

### GCPROFILE THERM

Thermally separated profile system in fine-framed design for a sophisticated appearance. For installation situations where special emphasis is placed on high energy efficiency, i.e. the lowest possible heat loss in winter or cold loss in summer. This profile system is also used when there are increased requirements for the tightness of the sliding door system. It is particularly suitable for exterior doors that are exposed to weather conditions and for interior doors that have to meet increased demands for sound insulation.

### TOUGHENED SAFETY GLASS CLAMPING PROFILE

Profile system for 10 mm or 12 mm toughened safety glass. The glass pane is clamped in place near the top. Additional aluminium profiles at the sides and bottom ensure tightness, floor guide and compatibility with DIN 18650.

### ALL-GLASS SYSTEM (GGS)

All-glass design fittings for single point fixing offer maximum transparency. All the visible door fittings are made of solid stainless steel.

### INTEGRATED ALL-GLASS SYSTEM (IGG)

The profiles and the fitting system are integrated invisibly between the panes – without protruding or visible parts on the glass pane.

### FRAMED MOVING LEAF DOOR (ON-SITE)

The drive can be combined with door leaves made of a wide range of different frame profile systems, also thermally separated.

### WOODEN LEAF (ON-SITE)

The drive can be combined with door leaves on-site made of a wide range of materials e.g. wood.

### HERMETIC LEAF

Use in areas with increased hygiene requirements, see GEZE Hygienic Doors on our website.

**FITTING VARIANTS**

	ECdrive T2	Slimdrive SL NT	Slimdrive SL RC2	Powerdrive PL	Slimdrive SLT	Slimdrive SL BO
ISO glass fine-framed	●	●	●	●	●	●
MONO glass fine-framed	●	●	-	●	-	-
GCprofile Therm, energy-efficient profile system fine-framed	●	-	-	-	-	-
Toughened safety glass clamping profile	●	-	-	●	-	-
All-glass system (GGS)	-	●	-	-	-	-
Integrated all-glass system (IGG)	-	●	-	-	●	-
Framed moving leaf door (on-site)	●	●	-	●	-	-
Wooden leaf (on-site)	●	●	-	●	-	-
Hermetic leaf	-	-	-	●	-	-

● = yes | - = not available



ISO glass fine-framed



MONO glass fine-framed



GCprofile Therm



Toughened safety glass clamping profile

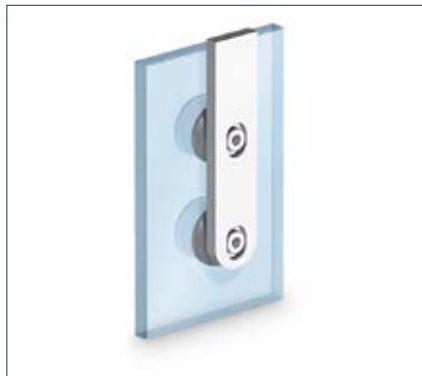

All-glass system (GGS)



Integrated all-glass system (IGG)



Framed moving leaf door (on-site)



Wooden leaf (on-site)



Hermetic leaf



SLIDING DOOR

# Accessories

Naturally, you'll need switches to operate your automatic sliding doors. Learn about the convenient programme switches in our extensive range of accessories, with which a variety of modes of operation can be set. You'll also find everything you need for activation, whether automatic or manual. And last but not least, we present you with our various locking options.



# Operation of automatic sliding doors

## PROGRAMME SWITCHES FOR SELECTING THE MODE OF OPERATION FOR AUTOMATIC SLIDING DOORS

GEZE offers programme switches for a wide range of individual demands. The switches are suitable for universal use – for surface-mounted or flush-mounted installation. The following switch types are available:

### DISPLAY PROGRAMME SWITCH (DPS)

### KEYPAD PROGRAMME SWITCH (TPS)

### MECHANICAL PROGRAMME SWITCH (MPS)

The following modes of operation can be set:

- **"Hold open"**: The door moves to the OPEN position and remains open. Movement detector or opening push button are deactivated.
- **"Night"**: The movement detectors are switched inactive, the door closes. Option: The door leaves are locked electrically to prevent forced opening.
- **"Exit only" (one-way)**: The door only opens and closes when someone goes out from the inside. The movement detector outside is switched inactive, the one inside is switched active.
- **"Automatic"**: The door opens as soon as it is activated via the movement detector or keys, and closes after a certain time that can be individually adjusted. Safety sensors protect the leaves' travel path. If there is someone in the door opening, the door will not close.
- **"Reduced opening width"**: The door opens only part of the possible opening width (can be set). In emergency exits, the reduced opening width must be at least as large as the required escape route width. The reduced opening width may not be less than 30 % of the opening width.
- **"OFF"**: Drive and sensors are switched off, the door leaves can be moved manually.

## PROTECTION OF THE PROGRAMME SWITCHES

Automatic sliding doors in escape and rescue routes must be secured against operation by unauthorised persons. The mechanical programme switch (MPS) is also available in a lockable version. The display programme switch (DPS) and keypad programme switch (TPS) can be combined with a key switch. Alternatively, these programme switches can be secured using a code.



Display programme switch (DPS)



Keypad programme switch (TPS)



Mechanical programme switch (MPS)

# Automatic activation

## RELIABLE ACTIVATION WITH GEZE SENSORS

### COMBINED DETECTORS

Combined detectors are radar movement detectors using an infrared light curtain. Activation and protection are integrated in the sensor, reducing installation efforts. Individual attachment possibilities through wall, ceiling or integrated ceiling recess installation provide lots of design freedom. The use of a remote control guarantees quick and easy commissioning. The sensor is activated reliably on the basis of direction detection and cross-traffic suppression. Slow movements can be detected thanks to the “slow motion detection” feature. The protection area can be configured as required. Combined detectors for escape and rescue routes offer maximum safety thanks to the integrated self-monitoring function.

### RADAR MOVEMENT DETECTOR

Radar movement detectors register all objects that move within the radar field. All movements within the radiation range cause a time-delayed reflection which is forwarded as a door opening signal. The pre-programmed convenience setting of the GEZE radar movement detectors ensures they can be put into operation quickly. Automatic configuration is possible via keys or a remote control. Reliable detection is achieved with a clearly defined radar field. Energy can be saved through detection of people's direction of movement. Unwanted door opening is avoided since cross-traffic can be faded out.



GC 363+ combined detector



GC 365 combined detector



GC 308 radar movement detector

# Manual activation

## PUSH BUTTON

Push buttons for the wireless activation of doors – reliable, convenient and safe at the push of a button.

## CAPACITIVE LED SENSOR SWITCH

The design-oriented and sturdy LED sensor switch makes intuitive and straightforward operation possible. No great efforts are required for activation – touching the button slightly is sufficient. Suitable for indoor and outdoor use, the LED sensor switch can be recognised easily in the dark thanks to the blue LED lighting. In addition, the sensor has Braille lettering on it. An acoustic and visual signal signals activation through the push button. The push button is waterproof, impact-resistant and protected against vandalism. This makes it very well suited for outdoor use or installation in the floor.

## NON-CONTACT PROXIMITY SWITCH

With the GC 307+ interior doors without a haptic perception requirement can also be activated cleanly and comfortably. The sensor ensures bacteria-free access to toilets, for example, or germ-free conditions in hotel kitchens, swimming pools and doctors' surgeries. The pulse generator is installed at hand height and precisely detects people and objects – independently of their direction of movement – both in the direct vicinity of only 10 cm, as well as 60 cm away. The different scanning ranges can be optimally adapted to existing environmental conditions and the interests of the user groups. Non-contact sensors offer a high level of operating comfort – people only need to approach them to trigger the automatic opening mechanism – and the advantage of absolute hygiene. The optimum system structure permits simple and time-saving installation in the flush-mounted box. The colours of the LEDs can be set, and it is also possible to use individual pictograms to visualize the areas of application.

## WIRELESS ACTIVATION

Radio transmitter are used for wireless activation of doors and windows as a multi-channel solution. For every additional channel, an additional electrical device or function can be switched at the push of a button. Thanks to the very small size of the wireless modules, radio transmitter can easily be integrated in the drive or in a flush-mounted box. They can also be clipped directly into the elbow switch and mounted without wires, e.g. on glass.



Push button



LED sensor push switch



GC 307+ non-contact proximity switch



Wireless activation



Plastic elbow switch



Stainless steel elbow switch IP65

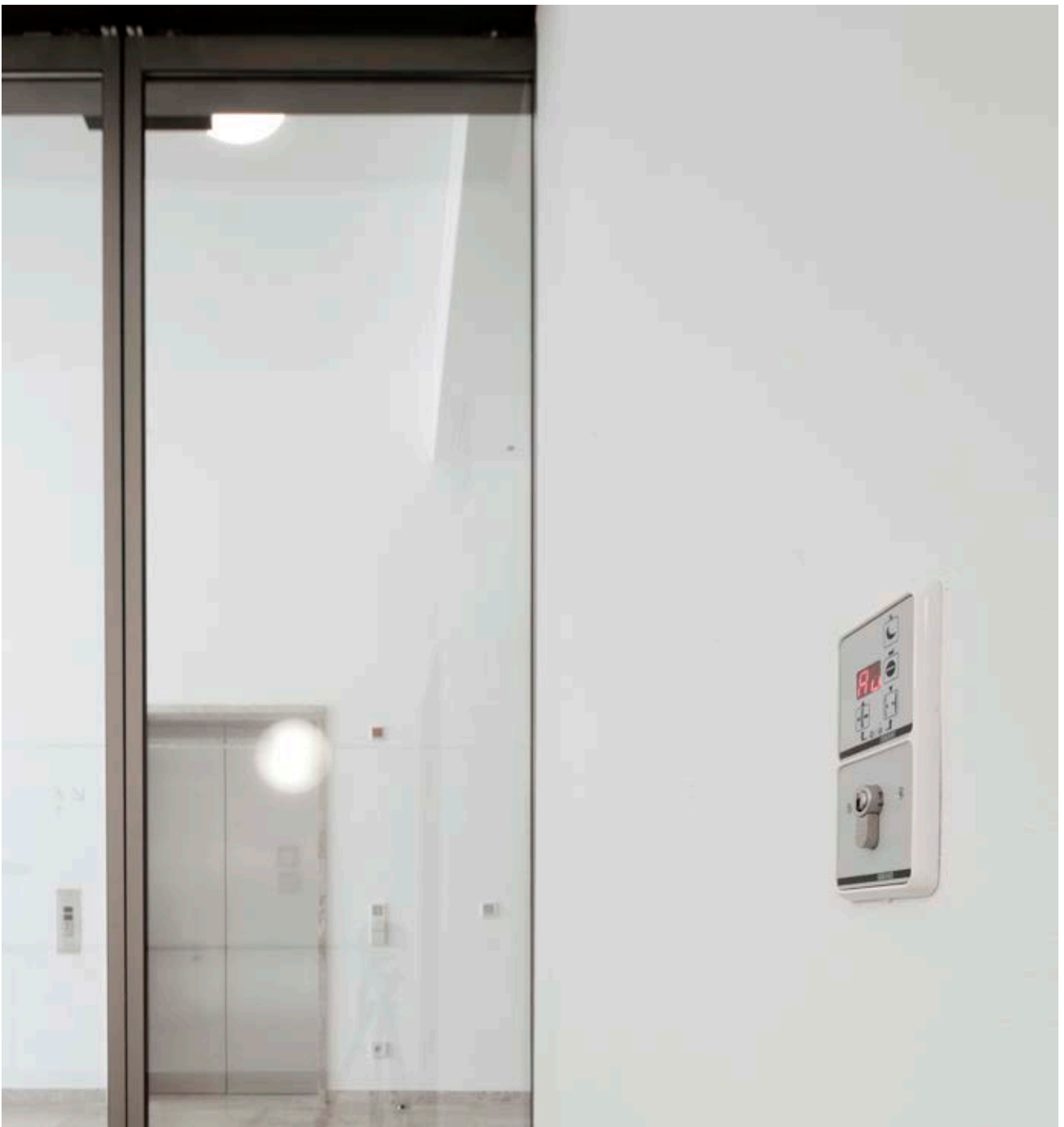

Key switch + Display programme switch + Slimdrive SL-FR (photo: Dirk Wilhelmy / GEZE GmbH)

# Electronic protection

## ACTIVE INFRARED DETECTOR

GEZE light curtains are used to protect posts, main and secondary closing edges for both internal and external applications. The light curtains have an invisible and non-contact protective device. Precise detection is possible through a clearly defined field, the size of which can be adjusted. Individual applications allow the use of light curtains as safety sensors or opening impulse generators.



GC 339+ active infrared detector



GC 341 active infrared detector

# Mechanical protection

## PROTECTIVE LEAF

Protective leaves are used on escape and rescue routes if it is not possible to secure the secondary closing edges using light curtains. Automatic sliding doors on escape and rescue routes must be able to be opened at any time.

## SAFETY LEAF

Safety leaves are used to protect the cavities behind automatic sliding doors in mullion-transom constructions.



Protective leaf



Safety leaf

Protective leaf

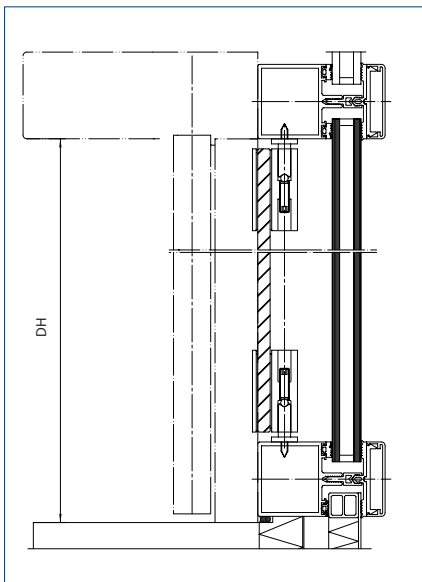

DH = passage height

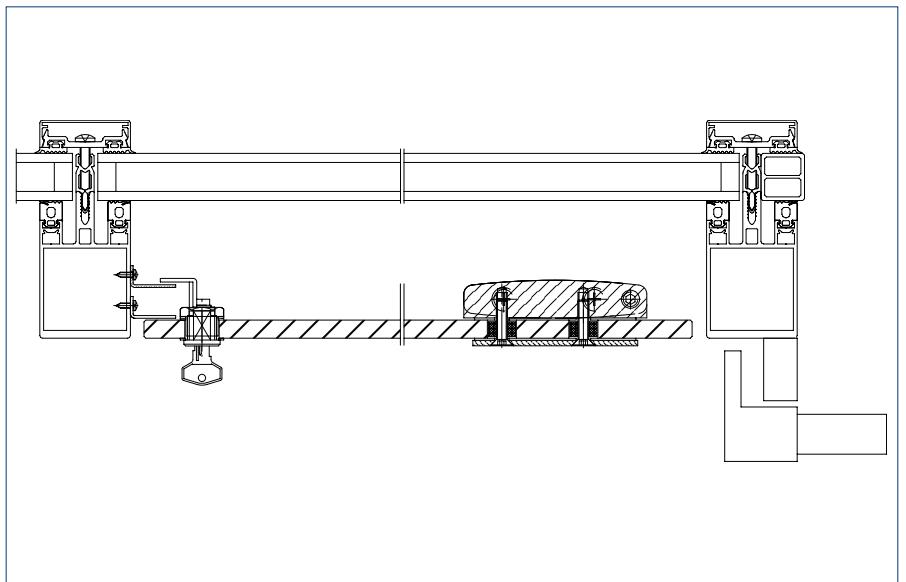

# Locking mechanisms

## LOCK M HOOK BOLT LOCK

Lock M is a manual hook bolt lock for the Slimdrive SL NT and ECdrive T2 sliding door systems. This high-quality locking mechanism is invisibly built into the vertical profile of the door leaves, allowing the door to be locked and unlocked quickly and reliably. The door can be locked and unlocked from the inside or outside using a key in the lock which is installed at a convenient height. The lock possesses an euro profile cylinder with 3, 6 or 9 keys with the construction length 32 mm (16/16). If standard construction lengths such as 60 mm (30/30 Euro-profile double cylinder) or 40 mm (30/10 Euro-profile half cylinder) are used, danger areas emerge on the basis of the surviving cylinder, so that a restriction of the opening width is necessary.

The Euro profile cylinder can survive without restrictions if no protective leaves are available on the inside. As an option, GEZE can provide an escutcheon plate for standard lock cylinders for installation on the drive side / inside. The extremely sturdy Lock M provides excellent protection against vandalism and unauthorised access.

## LOCK A HOOK BOLT LOCK

Lock A is a motorised hook bolt lock for the Slimdrive SL NT and ECdrive T2 sliding door systems.

This high-quality single or two-point locking mechanism allows the door to be locked and unlocked quickly and reliably. The locking motor is invisibly integrated into the vertical profile of the door leaves. The sliding door control unit makes parameter setting and control easy. The manual emergency unlocking facility allows the door to be opened from the inside at any time in the event of a power failure.



Lock M hook bolt lock



Lock M hook bolt lock installed



Lock A hook bolt lock



Lock A hook bolt lock installed



GEZE Slimdrive SL NT-FR sliding door system, Grosspetertower Zürich (photo: Lorenz Frey / GEZE GmbH)

### TOOTHED BELT LOCKING

This electromagnetic two-stages locking system ensures more safety, because it stays locked even without electric current. Manual emergency unlocking is possible at any time. Typical for this type of locking mechanism is permanent monitoring by the control unit. Up to two contacts for external applications (e.g. alarm systems) can be integrated as an option. Thanks to the free choice of positioning in the drive, the toothed belt locking is not only easy to install, it also makes special locking functions possible, e.g. locked pharmacy opening of the sliding doors.

### FLOOR LOCK

The floor lock is used for the easy locking of door leaves with the fine-framed ISO profile system at floor level. Customary Euro profile cylinders can be used for the floor locks. This means the solution is suitable for optimum integration in closing systems. Operation is manual, with the key, either only from the inside or from both the inside and outside.

### ROD LOCKING

Rod locking increases safety and protection against burglary. The multi-point locking – both upwards and in the ground – provides solid resistance against attempts to be levered open. The locking bar is integrated invisibly in the fine-framed ISO profile system. The system can be unlocked both electrically and mechanically. Rod locking can be used in the Slimdrive SL and Slimdrive SLT drives. Escape and rescue routes can also be protected by rod locking.

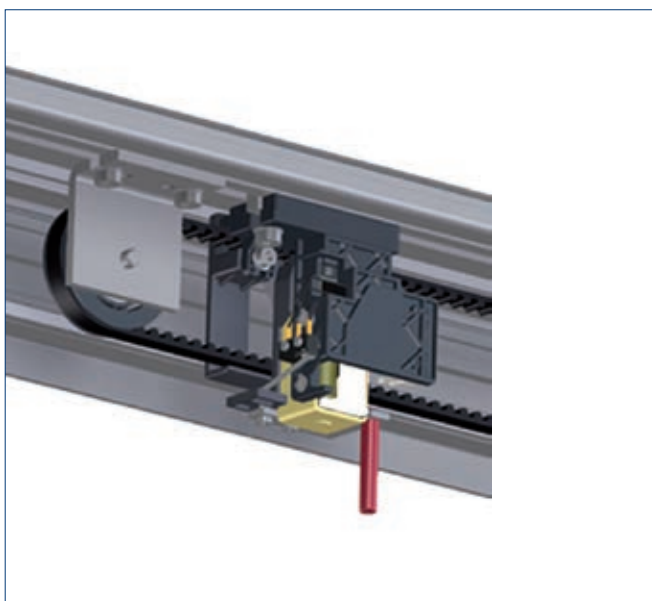

Toothed belt locking



Floor lock



Rod locking

# Service tools

## GEZE SERVICE APPS

myGEZE Connects and GEZEconnects enable a wireless connection via Bluetooth between a computer and GEZE automatic door systems. All settings for the door system can be conveniently configured, saved, sent by email and transferred as a log file via an intuitive graphical user interface. Diagnosis functions show the most important function parameters of the door system in real time, so that faults are recognised at a glance and can be eliminated. All the pre-settings can be taken over very easily for further door systems. The convenient documentation of commissioning, maintenance and diagnosis protocols as well as all statistical data can easily be downloaded at any time. Password protection to block operating parameters and servicing data guarantees there will be no unauthorised modifications.

## ST 220 SERVICE TERMINAL

Mobile, handy and straightforward – that is parameter setting for the automatic GEZE door systems using the ST 220 service terminal. Communication and data exchange between the service terminal and the drive unit is via an integrated RS485 interface. The large illuminated display is easy to operate thanks to the plain text display. The service terminal is equipped with a readout function for servicing and diagnosis work. Power is supplied via the door system. Password protection to freeze operating parameters and servicing data guarantees there will be no unauthorised modifications.

→ **Note:** Changes to parameters on GEZE drives may only be carried out by experts authorised by the manufacturer (GEZE) in accordance with DIN 18650/EN 16005



GEZEconnects



myGEZE Connects



myGEZE Bluetooth module



ST 220 service terminal





SLIDING DOOR

# Cable plan sliding door control units

In order to show you the connection of the activation devices and sensors, we have created a cable plan for you. Scroll further to "References" if you want to see some innovative buildings in which GEZE sliding door systems are used.



# Cable plan sliding door control units

For more detailed information about connection of the activation devices and sensors see the wiring diagram 160924 (English version).

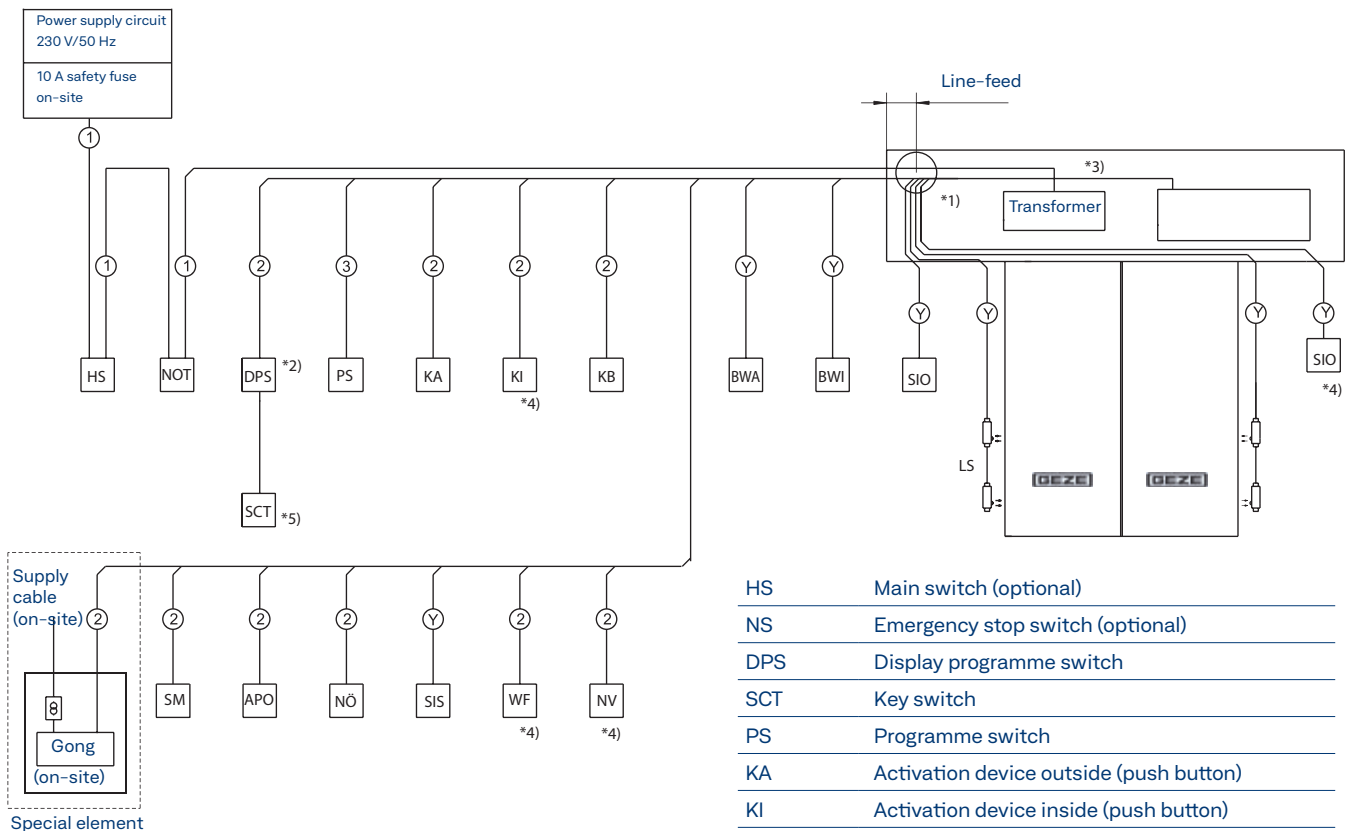

Wire cross-section: 1 = NYM-J 3 x 1.5 mm<sup>2</sup> | 2 = I-Y(ST)Y 2 x 2 x 0.6 mm | 3 = I-Y(ST)Y 3 x 2 x 0.6 mm | Y = GEZE scope of delivery

HS	Main switch (optional)
NS	Emergency stop switch (optional)
DPS	Display programme switch
SCT	Key switch
PS	Programme switch
KA	Activation device outside (push button)
KI	Activation device inside (push button)
KB	Activation device "authorized"
BWI/BWA	Movement detector (inside/outside)
SIO	Safety sensor "Open"
SM	Fault indicator Fault lamp or fault horn
APO	Pharmacy opening (only possible in combination with toothed belt locking)
NÖ	Emergency opening
SIS	Light curtain with movement detector KA or KI
WF	Interlocking door system, vestibule
NV	Emergency lock
LS	Photoelectric barrier <sup>*6)</sup>

→ **Safety:**

- Wiring according to VDE 0100
- Wiring, connection and commissioning may only be carried out by authorised specialists.
- GEZE does not accept any warranty and service performances in combination with third-party products

→ **Notes:**

- 1 Cable feed through the side plate or through the track on the left. To protect the cables, avoid sharp edges or use edge protection.
- 2 Cable length max. 100 m
- 3 Signal wires min. 5 m and power supply circuits min. 2 m from the wall
- 4 Push button (KI) not permitted in escape and rescue routes
- 5 Optionally, connect to escape and rescue route control units, alternatives without key switch: Program access code to the DPS via ST 220 or myGEZE Connects
- 6 Photoelectric barriers, according to DIN 18650 / EN 16005 must not be used as the only protection in the closing area

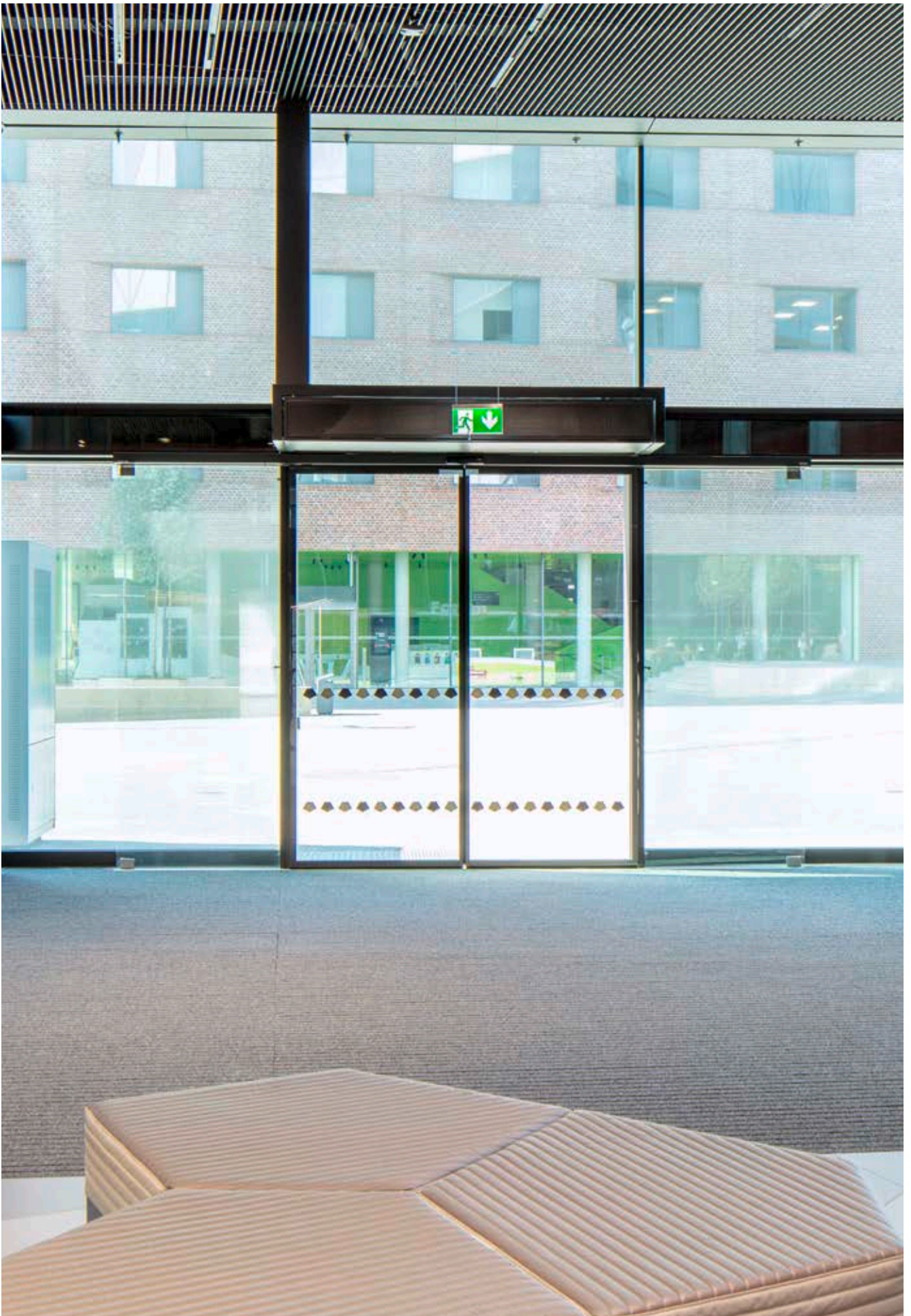

Slimdrive SL NT-FR with IGG glass leaves (photo: Jürgen Pollak / GEZE GmbH)





SLIDING DOOR

# References

Discover a selection of innovative buildings which we were able to equip with our automatic sliding door systems. Customers all over the world have praised the diverse functions and elegant design: Be it a first-class hotel, a state-of-the-art hospital, a representative retirement home, a renowned museum, an elegant administrative building or a heavily frequented station – the products and services by GEZE for automatic sliding doors are the first choice. We provide convenient and reliable drive units.





Powerdrive PL-FR, Grosspetertower Zurich, Switzerland, (photo: Lorenz Frey for GEZE GmbH)



ECdrive T2 (photo: GEZE GmbH)



ECdrive T2 (photo: GEZE GmbH)



Slimdrive SL NT with vestibule, Augustinum, Stuttgart, Germany (photo: Dirk Wilhelmy)

# We are GEZE.

## For liveable buildings

GEZE stands for innovation, high quality and comprehensive support of building technologies. From the initial idea, planning and operational implementation with standard products to customised system solutions and individual service and maintenance plans. We offer an extensive product range of door, window and safety technology products and are a major driving force behind the digital networking of building automation.

### **GEZE GmbH**

Reinhold-Vöster-Strasse 21 – 29

71229 Leonberg

Germany

Telephone: +49 7152 203 0

Fax: +49 7152 203 310

Email: [info.de@geze.com](mailto:info.de@geze.com)

**[www.geze.com](http://www.geze.com)**